



Custom Conveyors & Automation for Robot Integration



Designing & Building Alternative Solutions

Alternative Engineering, Inc.
aeinc.com | sales@aeinc.com | 616.785.7200

Over/Under Conveyors	3
Coin Fed Magazine Dispensers	5
Robot Pick Magazine Dispensers	6
Lift Assists	7
Tryout Press Loader	8
Palletized Loop Conveyor	9
Accumulating Lift & Transfer Conveyors	10
Inspection Shuttles	12
Robotic De-Stackers	13
Complete Conveyor Systems	15
Custom Robotic Interface Conveyors	16
Dunnage Index Conveyors	17
Chain Conveyors	18
Multi-Lane Belt Conveyors	19
Belt Conveyors	20
V-Trough Belt Conveyors	21
Gravity Conveyors	23
Plastic Tote Gravity Conveyors	24
Specialty Conveyors	25
Extreme Duty Turntables	26
Turntables	27
Powered Carts	28
Robot Pick Carts with Precision Floor Locks	29
Pallets and End of Arm Tools	30
Dial Table for Assembly Machine	31
Dial with Marking and Vision	32
Inspection Stations	33

Over/Under Pallet Conveyors

A modular conveyor which incorporates fixtured part pallets on a continuous over under loop with asynchronous part transfer. Using a combination of a pallet conveyor, chain conveyor and pallet return system, parts travel on the pallets along the top of the conveyor while empty pallets are returned on the lower section of the conveyor. This Over Under is designed to transfer, accumulate and precisely locate your part for operator or robotic interface.

Special Features:

- Modular design allows for infinite sizes of system
- Parts can overhang pallet for narrow applications
- Pallets can be connected for long part applications
- Low profile reduces system footprint
- Economical, no elevators or separate return conveyors
- Pallet Stops & Lift & Locates are modular & adjustable
- Conveys a wide array of products

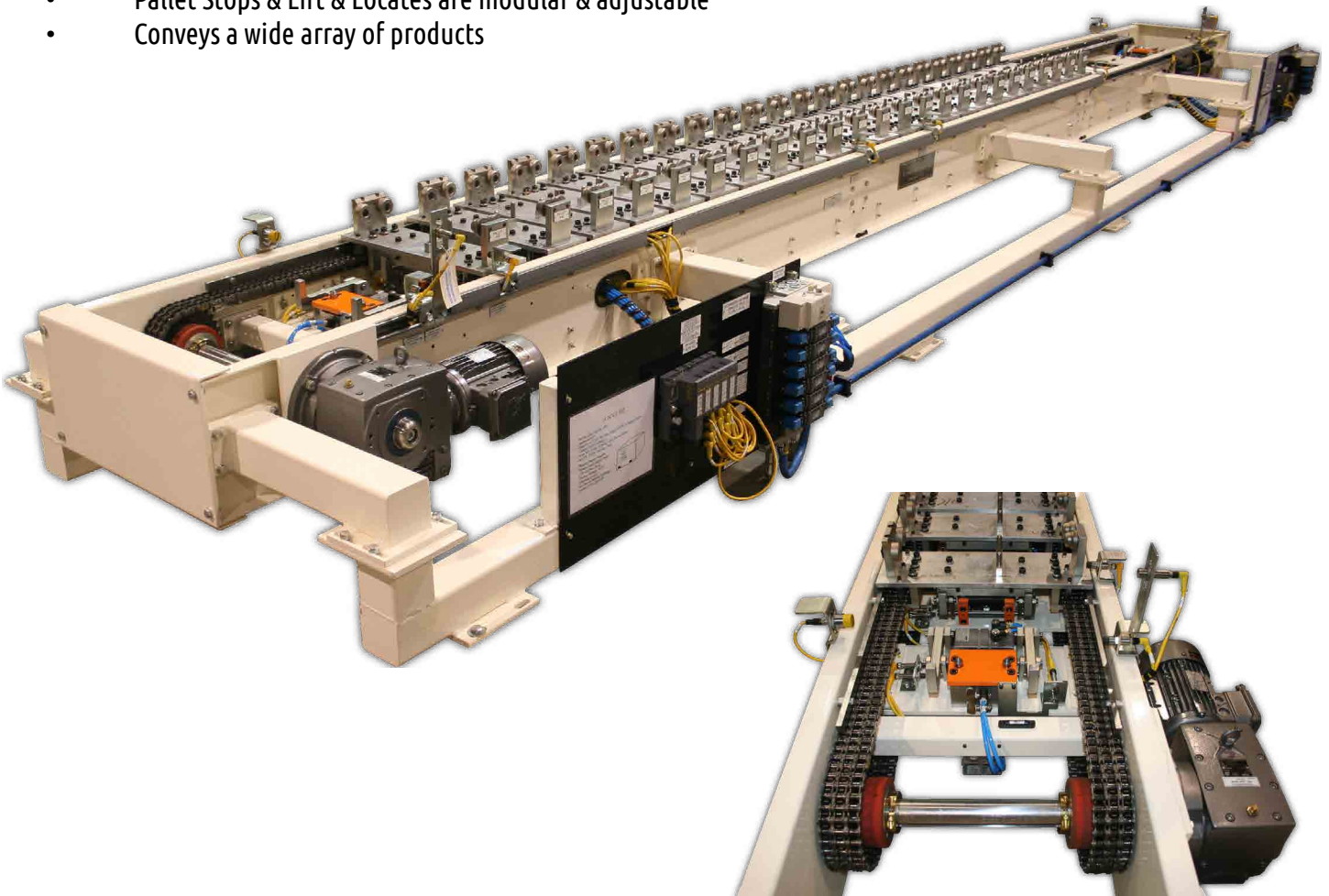

Recirculating Accumulating Over/Under Pallet Conveyor With Custom Pallet Fixtures

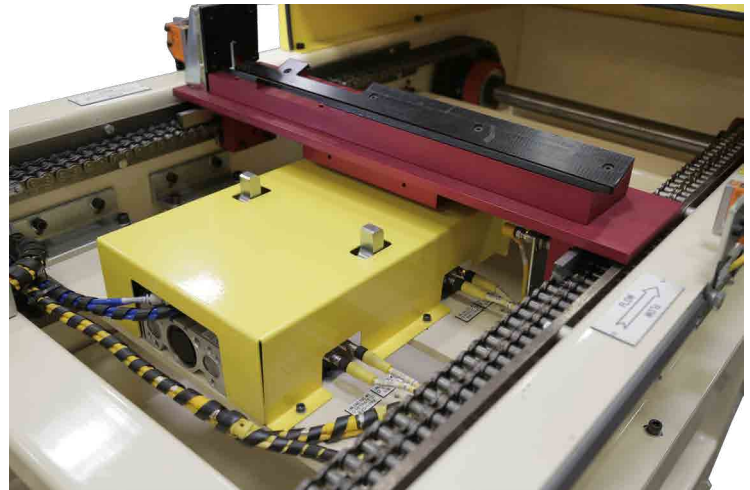
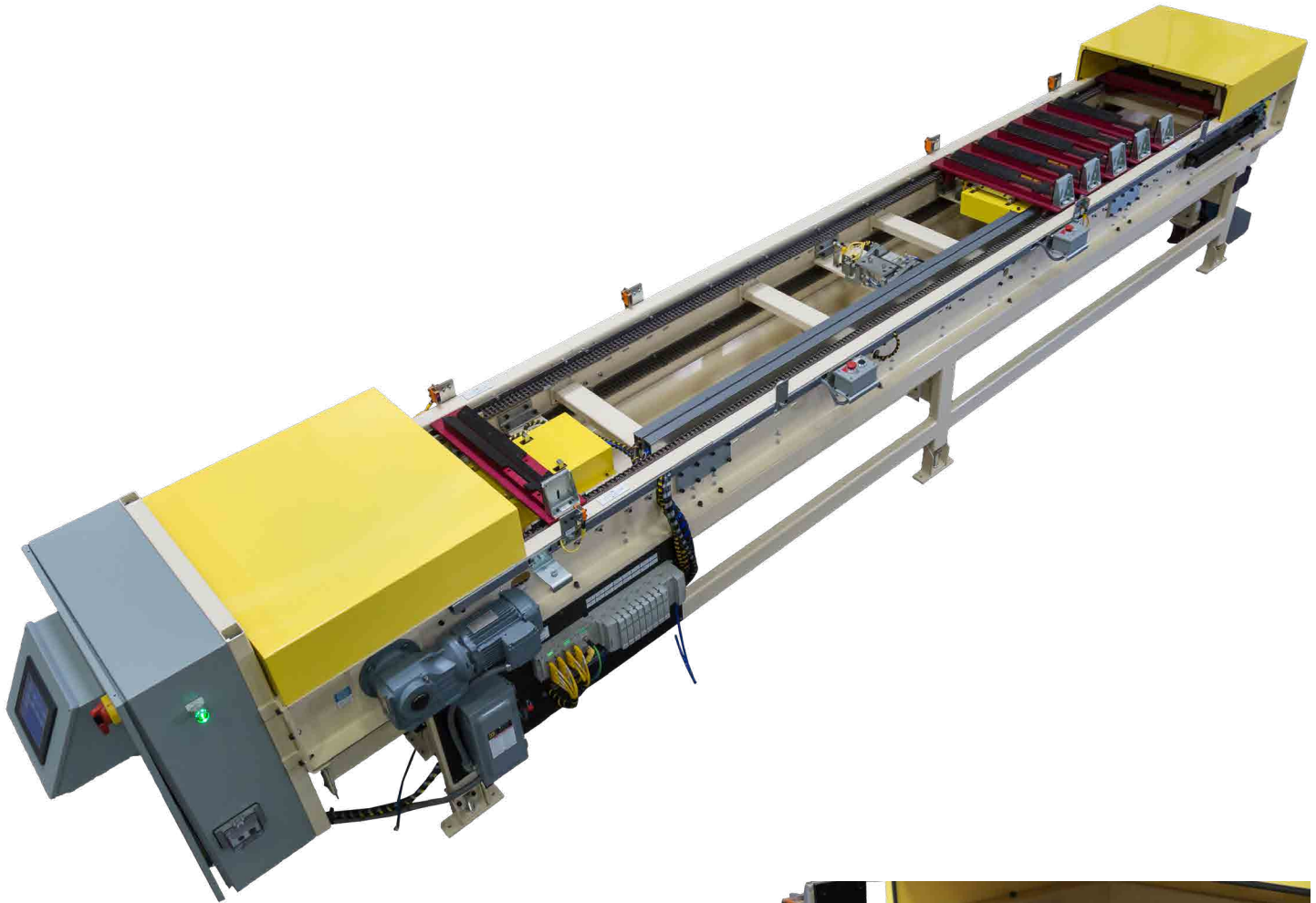

Bearing Race Dispensers with Removable Magazines



Felt Screen Feeder Dispensers with Removable Magazines



Precision "Pick" Dispensers with Removable Magazines



Ceramic Filter for Foundry Industry



Image Shown with Magazines Removed

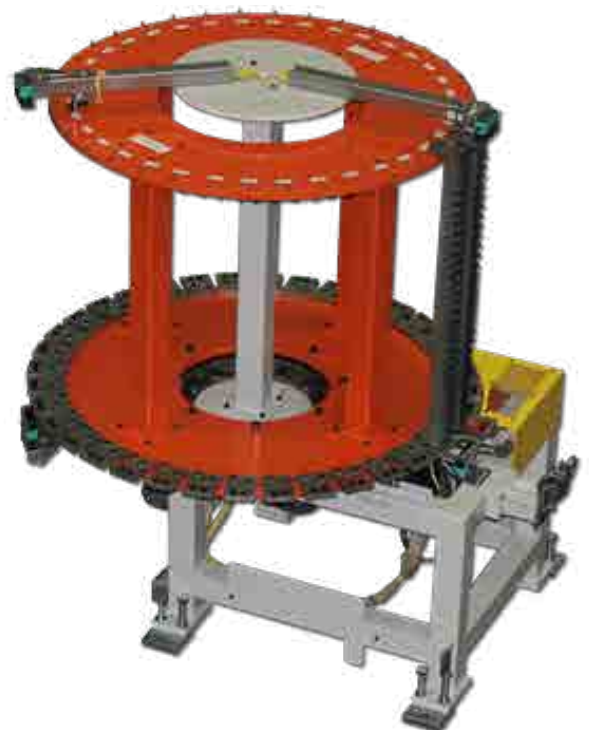

Re-Grip Pocket with Blow-Off

Box Side Tool



Body Side - Hook Tool

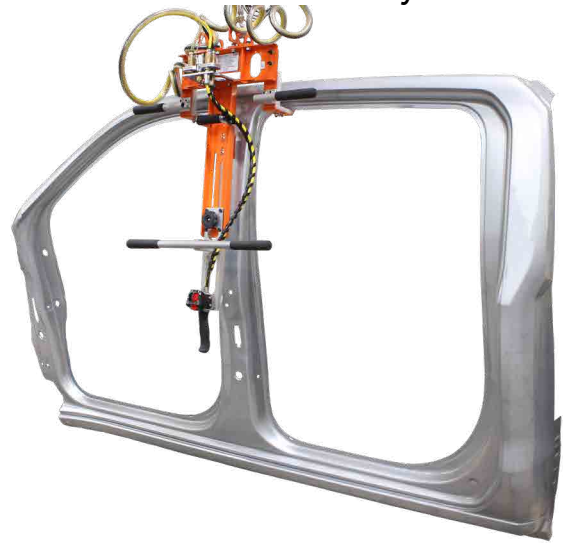

Hood Tool

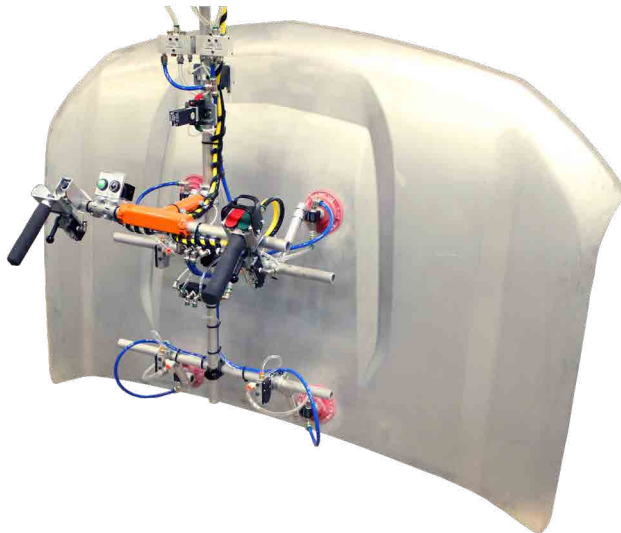

Roof - Tilt Tool

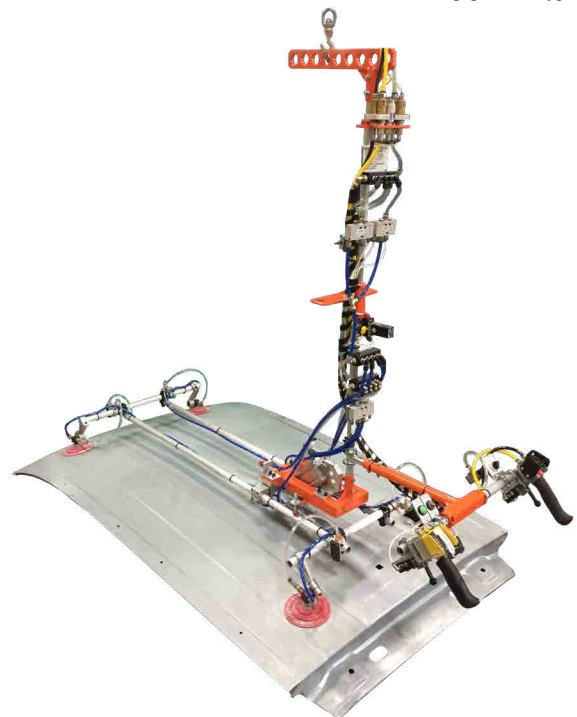

Manual Articulating Arm with Air Hoist



Control Handles

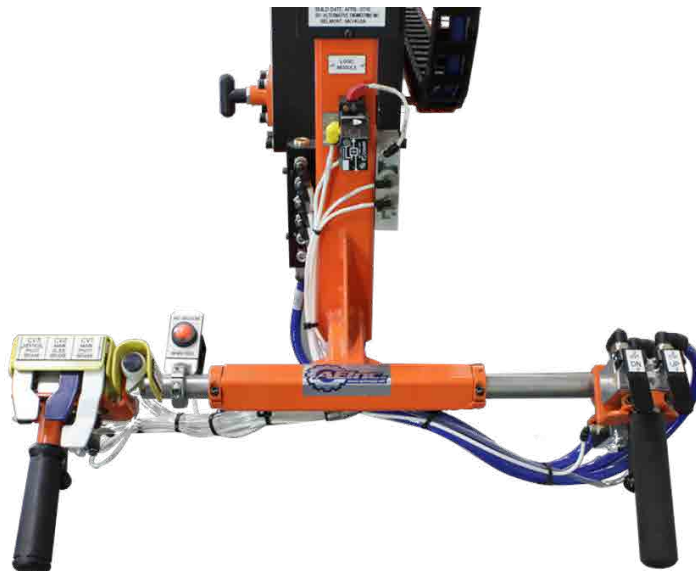

Manual Load/Unload
Small Foot Print

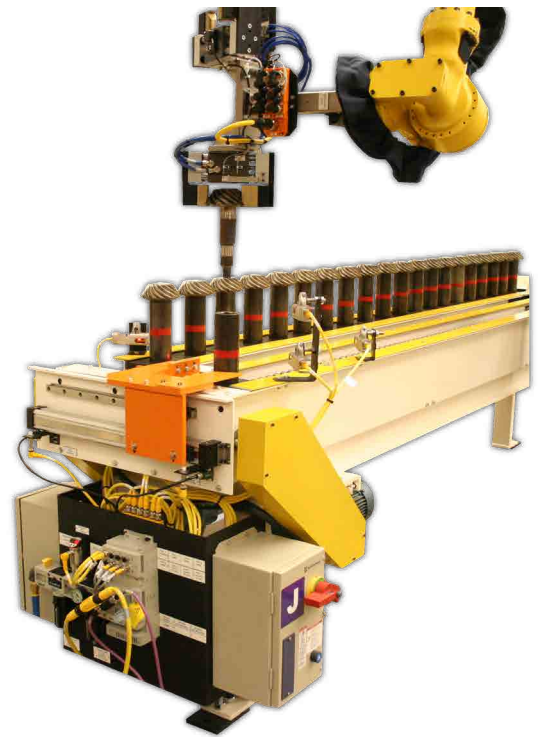
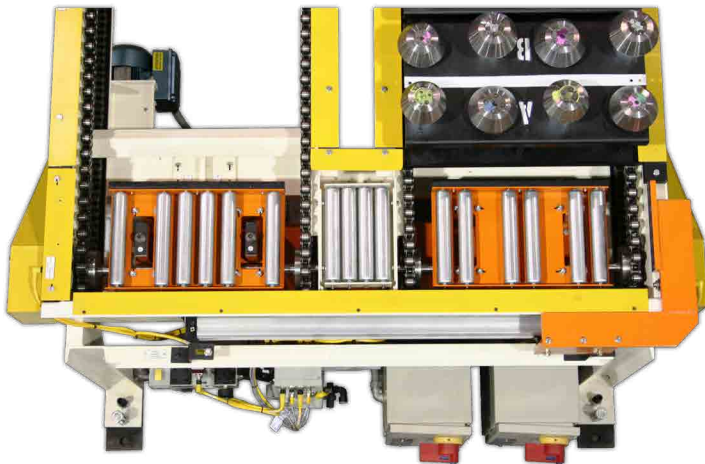

All conveyors are made to order

Weld Cell Feed Conveyor with Accumulation for Robotic Place and Pick



Cast Aluminum Accumulating Conveyor for Robotic Place and Operator Pick



Shuttle with Palm Buttons and Dog House Guarding

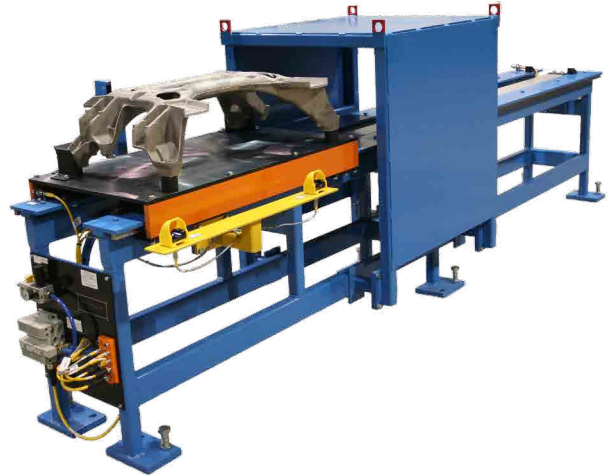

Custom Fixture with Drip Pans for Wet Parts

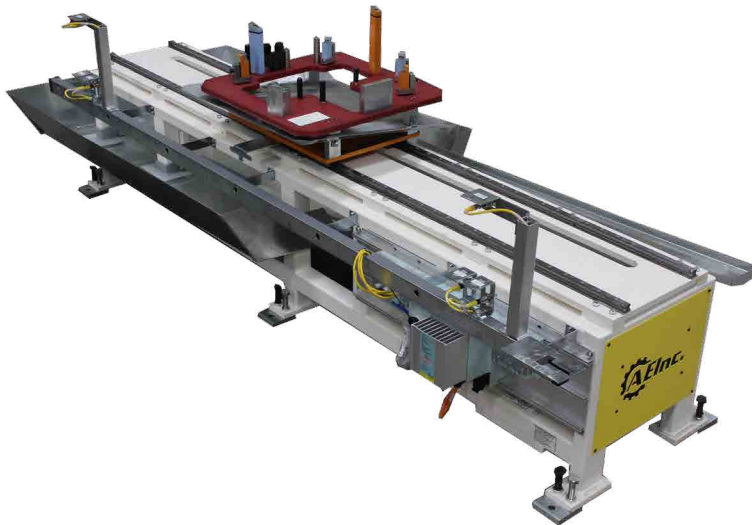

Heavy Duty Tote Shuttle Using Urethane Rollers

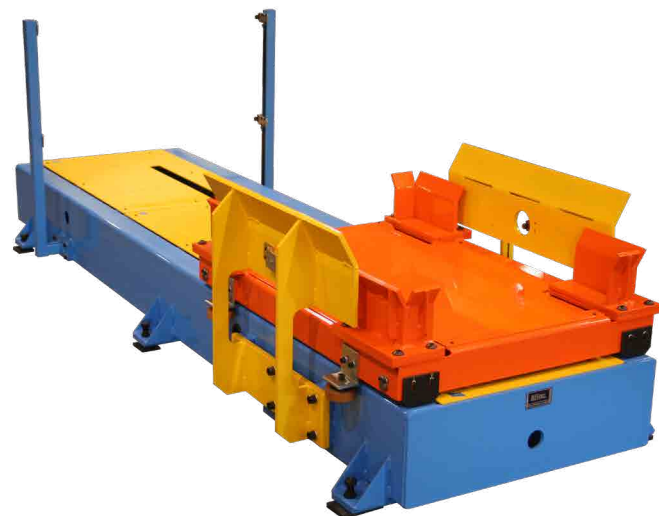

Sand Core Inspection Shuttle for Foundry Application Using Inverted Linear Bearings



All shuttles are made to order

Transfer Press Robotic De-Stacker with Adjustable Width Feed Conveyor



Conveyor Has Powered Height Adjustment and Powered Extend/Retract Features with Powered Blank Stack Carts

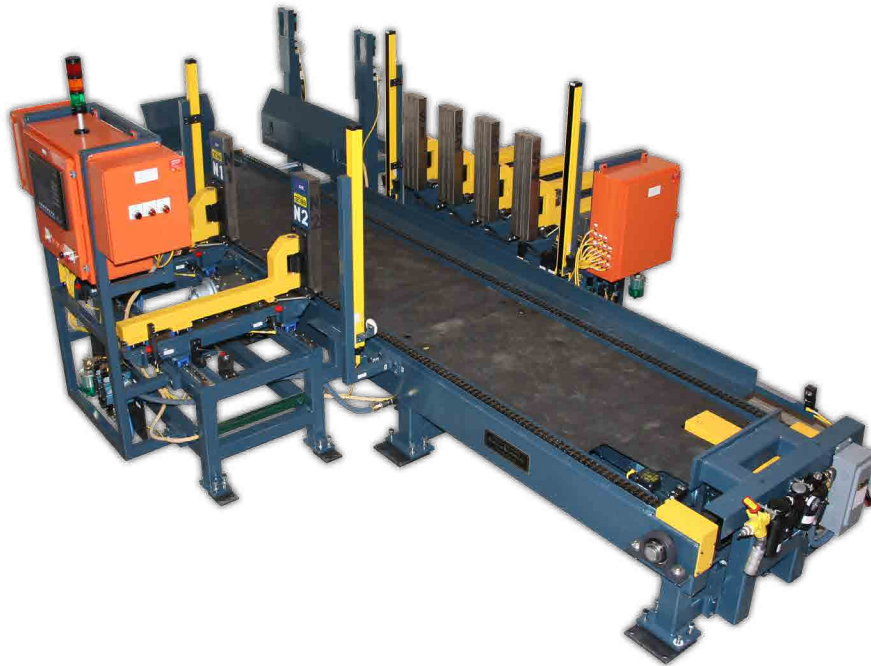

Pallet Chain Conveyor Feeding Powered Fanner Magnets for Robot De-Stacker

Robotic Engine Block Assembly Conveyors with Multiple Stations

Inspection Station

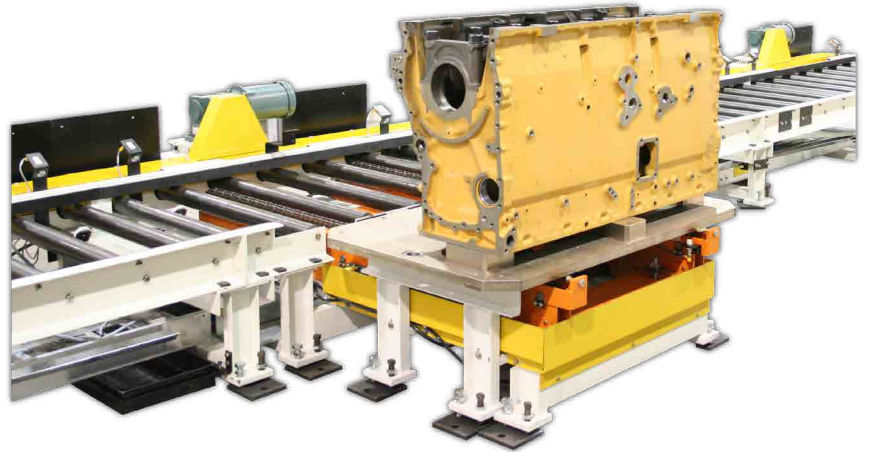

Robot Pick Conveyor

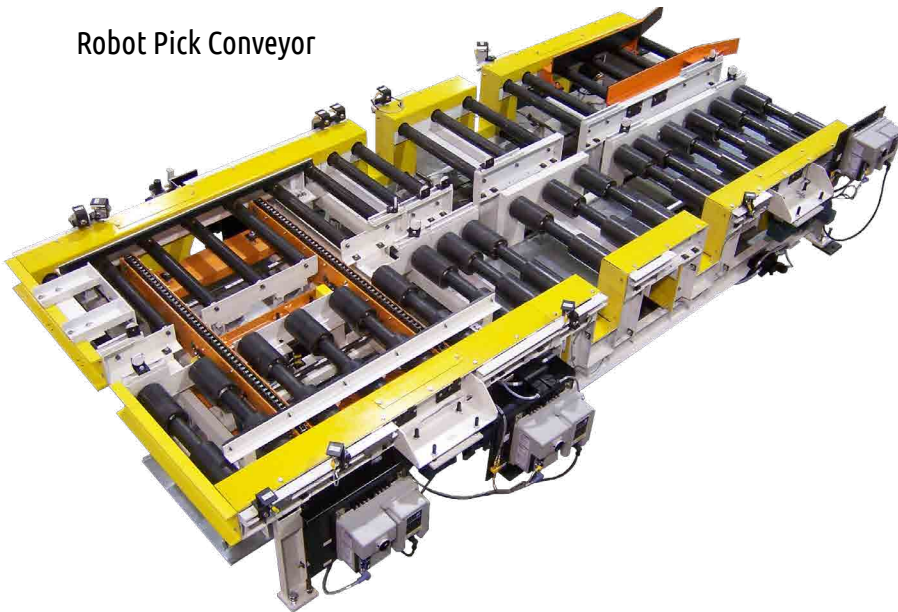

Aisle Crossover Station



Robotic Engine Block Assembly Conveyors with Multiple Stations

CDLR Loop Conveyors

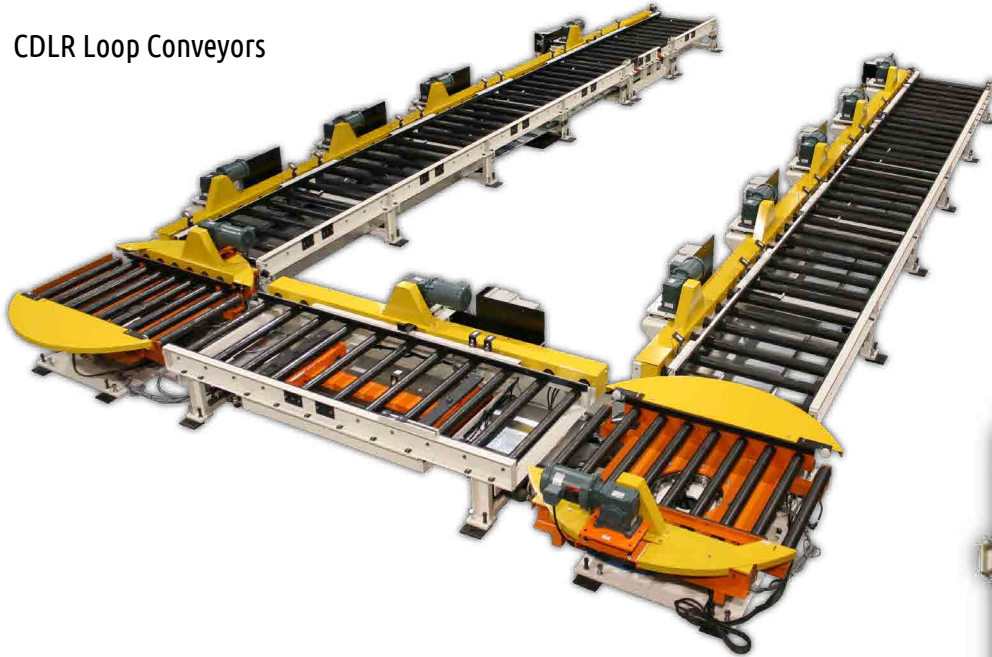

CDLR with Lift



CDLR and Pop-Up Chain Transfer for
Manual Inspection Station

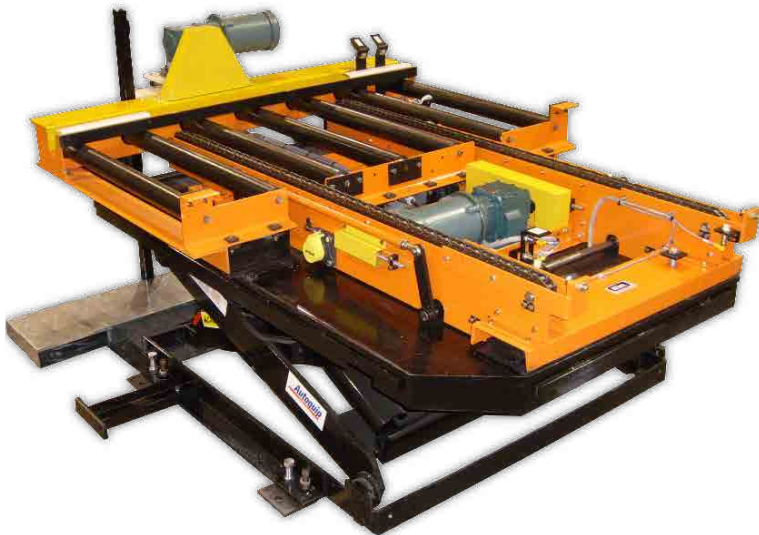

Powered Roller and Timing Belt Conveyors for Foundry Applications



Cast Block Powered Roller Conveyor with Slip Sleeves
Shown with Turntable Integrated Blade Stop

Sand Core Assembly Timing Belt Conveyors
with Powered Cart



Sand Core Timing Belt Conveyors
with Turntable

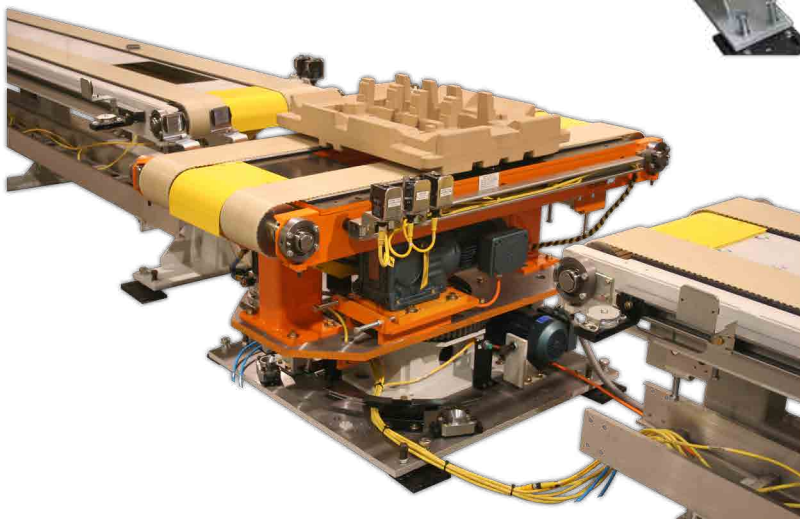

Multi-Station Over/Under Rack Indexer for Large Containers
Operator Unloads Dunnage from Second Floor



Lift and Transfer Rack Indexer
For Difficult to Convey Dunnage with non-Roller Friendly Bottoms

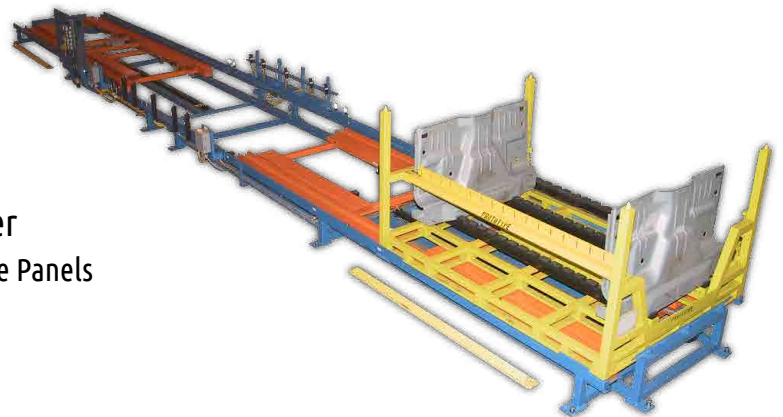

High Speed Precision Robot Feed Rack Indexer
Delivers Part Containers To and From Robot for Large Panels



CDLR with Pop-Up Chain Transfer



CDLR with Electric Lift for Chain Transfer with Turntable



Heavy Load Chain Transfer

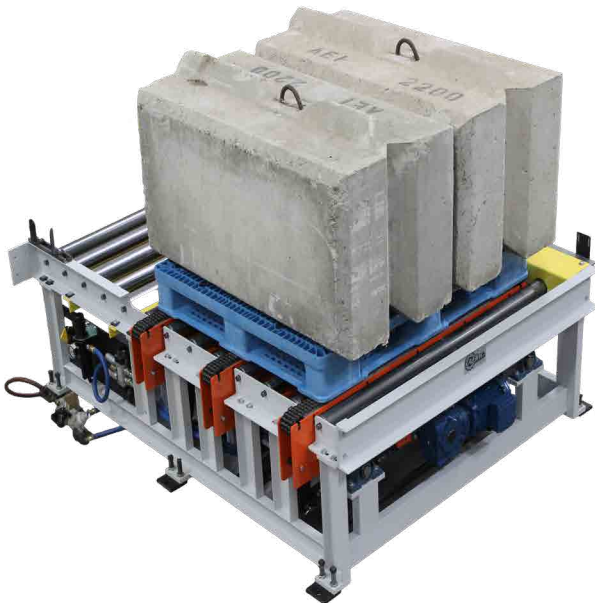

CDLR Feeding Heavy Duty Pallet Dispenser



Engine Block Finishing Conveyor
With Cross Transfer Rollers and Escapement



Custom Attachment Chain



Custom Pallet Chain Transfer

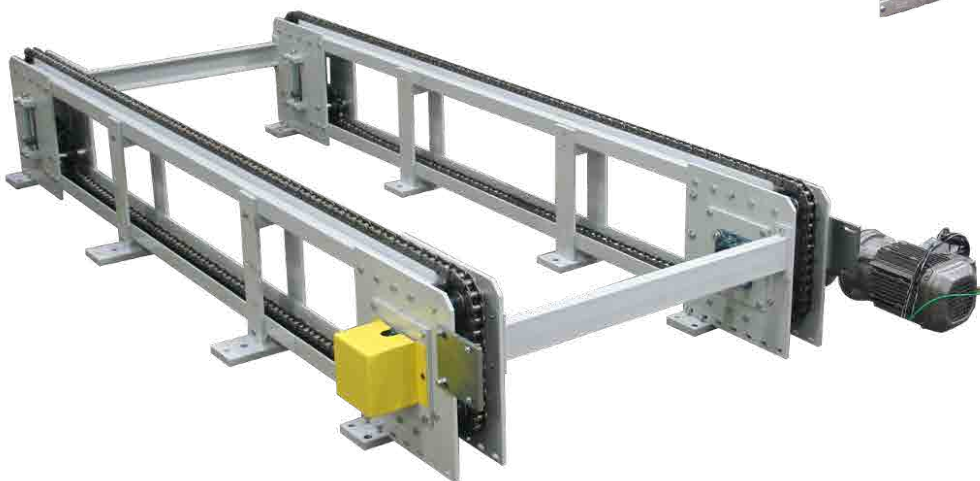

Telescoping Multi-Lane Belt Conveyor With Independent Control Side Shift Features, Powered Tilt, and Rollout

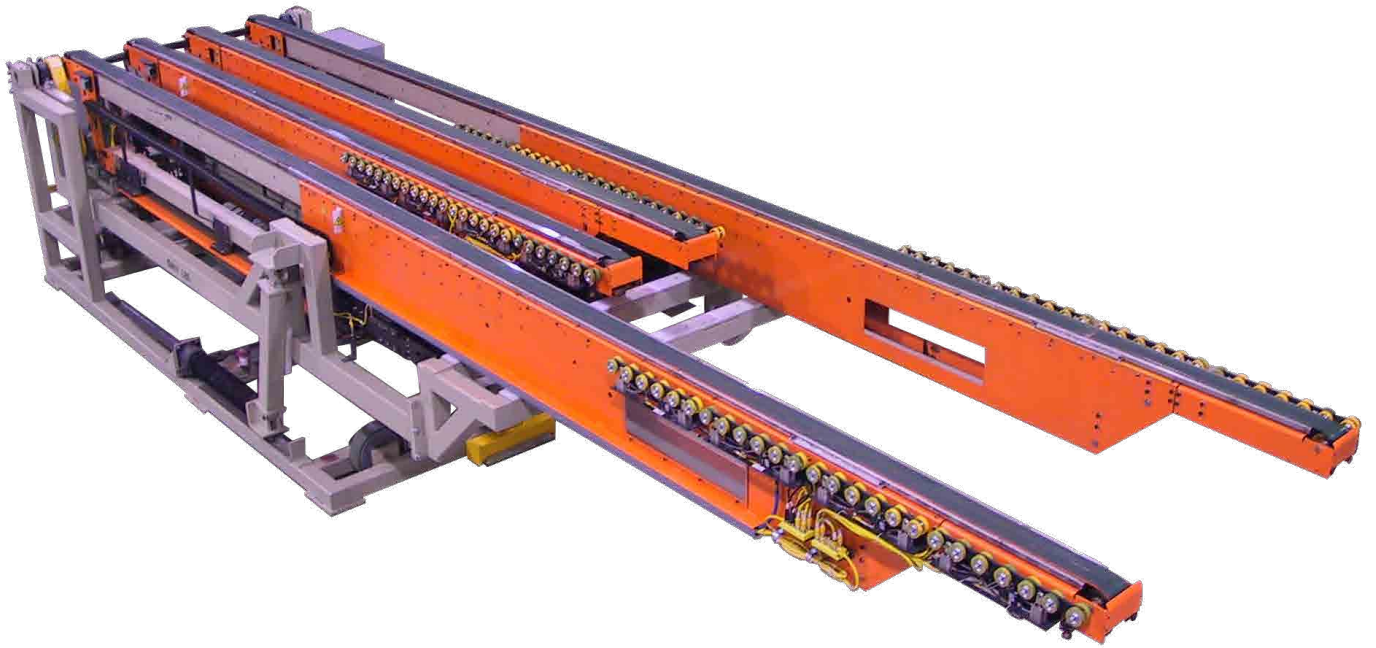

Transfer Press Unload Conveyor With Height, Width, and Extend/Retract Powered Adjustment



All conveyors are made to order

**Extra Heavy Duty Belt Conveyor
For Foundry Application**



**Timing Belt Conveyor
With Part Squeezer for Foundry Application
Sand Core Assembly Line**

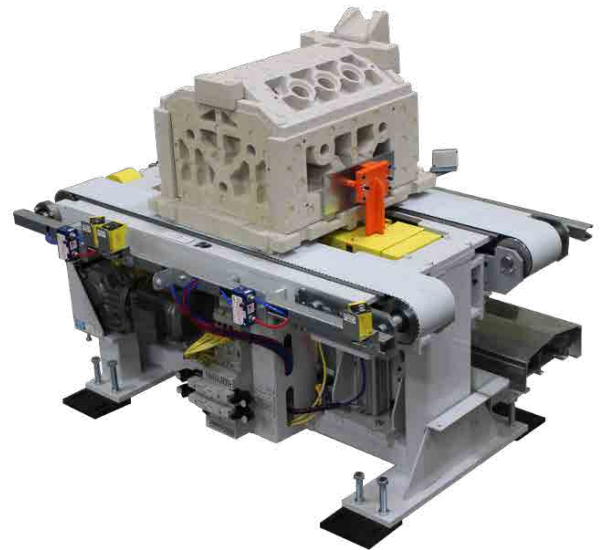

**Adjustable Width Twin Lane Belt Conveyors
With Powered Lift**





**Stainless Steel V- Trough Belt Conveyor
For Bagging Operation**



Inspection/Reject Part Conveyor
For Robot Place

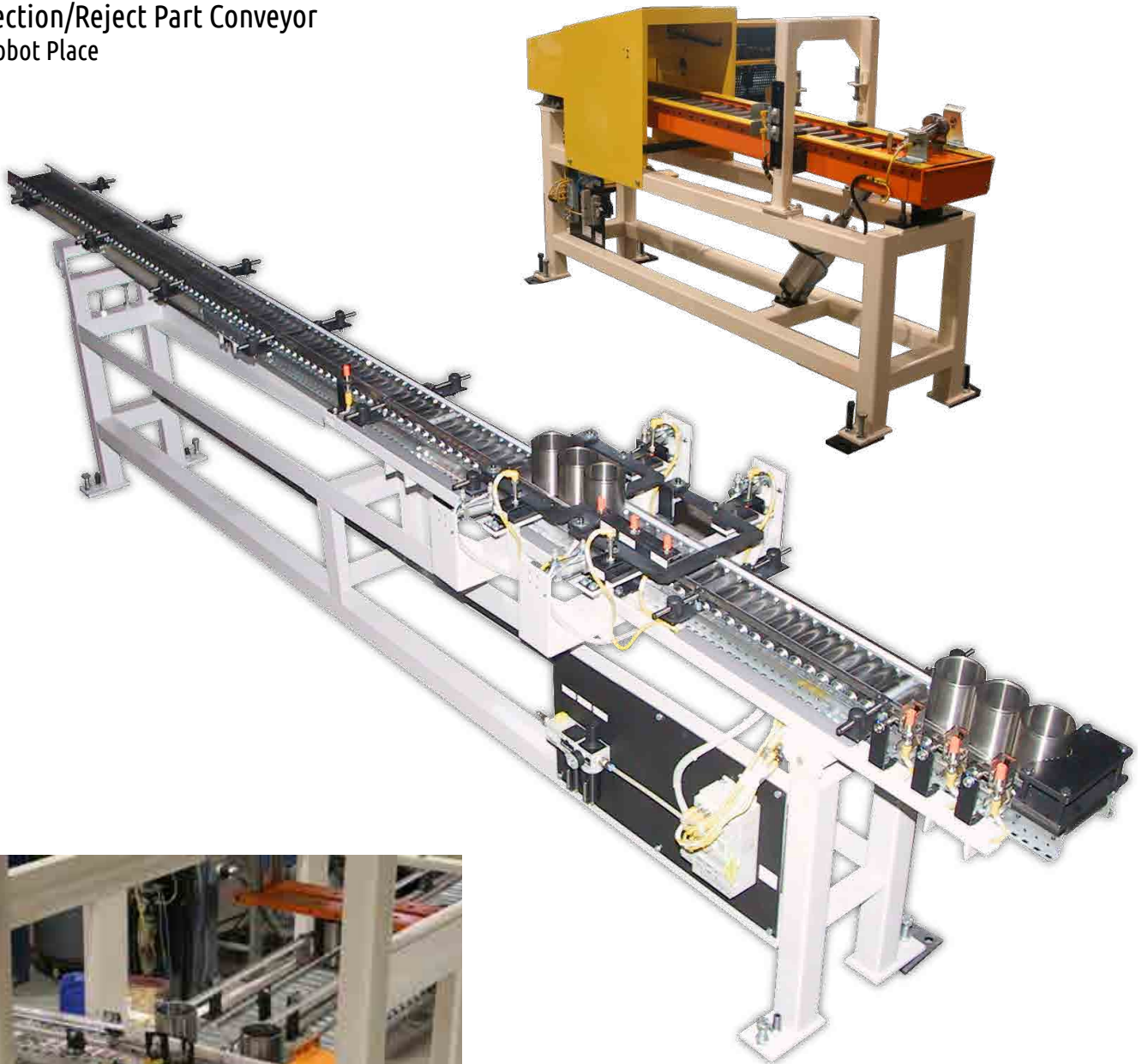

Piston Liner Gravity Feed Conveyor
With Meter and Turn Lanes

Gravity Feed Conveyor Robot Pick
Includes Custom 3 Part Meter and Crowd Device
Using All Air

Small Tote Aisle Jump Conveyor
All Air Logic Controlled



Over/Under Gravity Conveyor
With Integrated Tilt
Air Logic or PLC Controlled



4 Station Gravity Tote Conveyor
With Tilt Using All Air Logic Controls



Mini Over/Under Conveyor with Lift
Band Driven and Gravity Conveyors



Manually Fed Gravity Conveyor
Delivering Gas Tanks to an Assembly Line



Manually Operated Metering
No Air or Electricity Required

Precision Slat Conveyor
With Part Nest for Robot Place and Operator Pick



Glass Handling Conveyor
With Lift and Center Feature for Solar Panel Industry

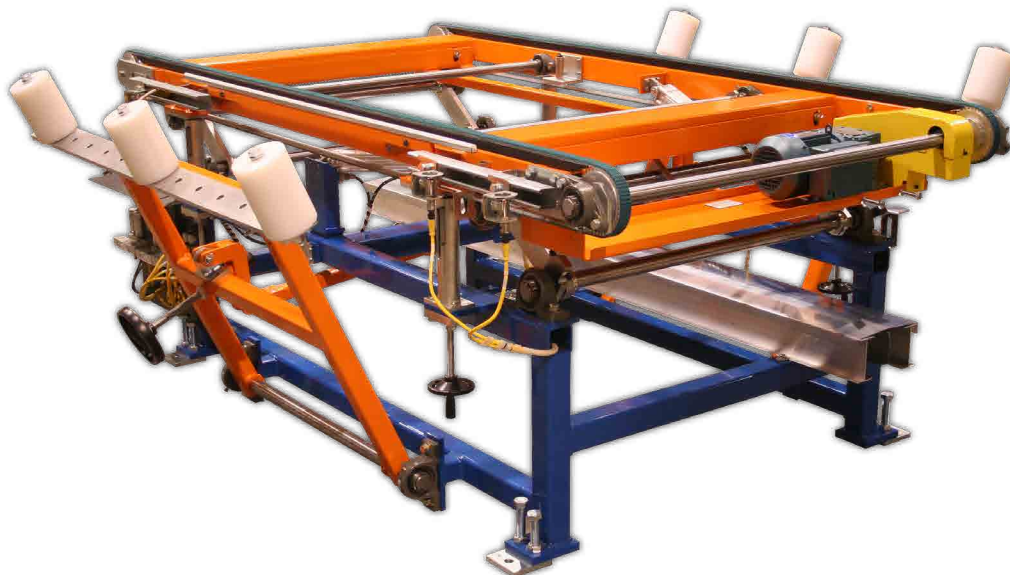

Large Container Turntable
With 2 Lifts and Tilts
20,000 Pound Capacity

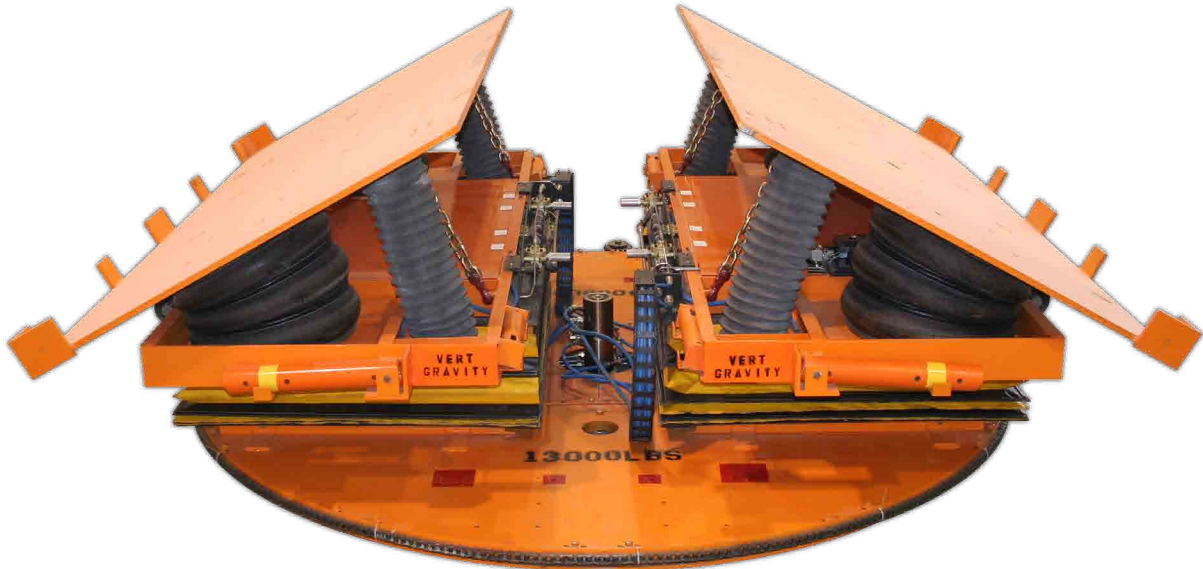

Add 4 Lazy Susan Manual Rotates to
Tilting Top for Total Container Accessibility

Tilting Tops



Robotic Interface Turntables Powered or Manual Rotate

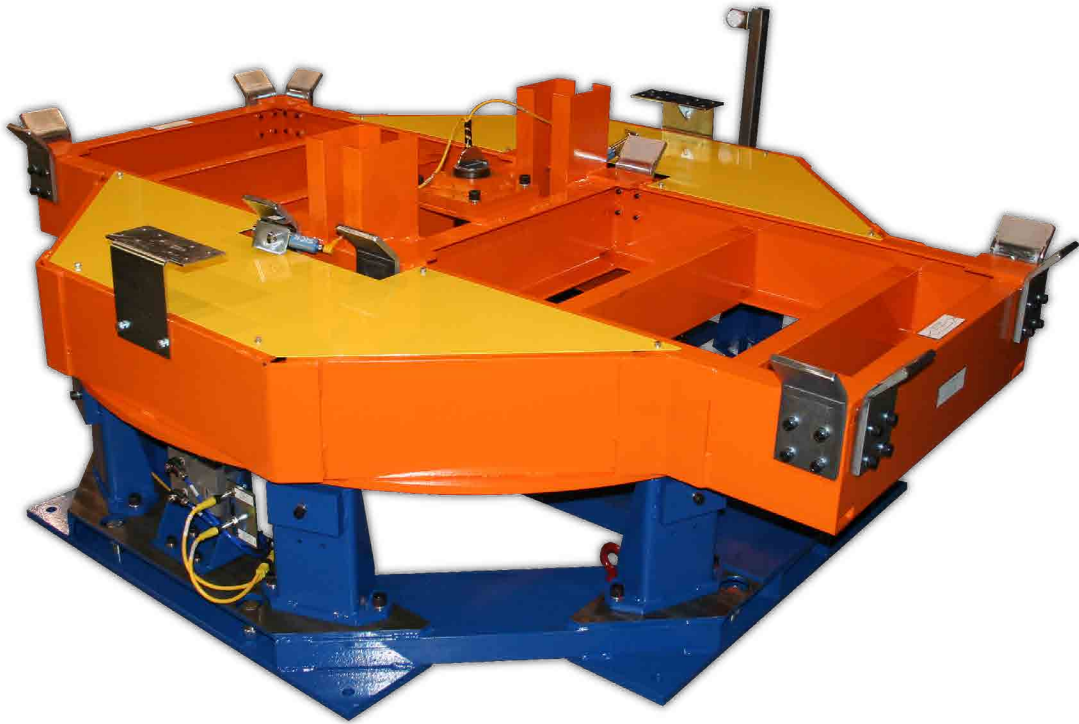

Air Powered 180° Turntable
With Hand Valve or Foot Valve

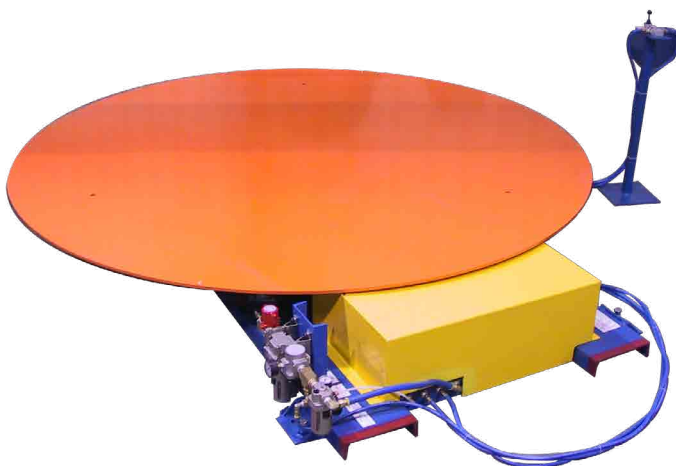

Manual 180° Turntable
With Locking Detent



Jumbo Sheeting Polishing Cart
Rack-n-Pinion with 4 Drive Motors



Trackless Powered Carts



Heavy Duty Air Motor Driven Cart



Precision Economy Pallets



Quick Release Floor Lock



Piston Pallet and EOAT

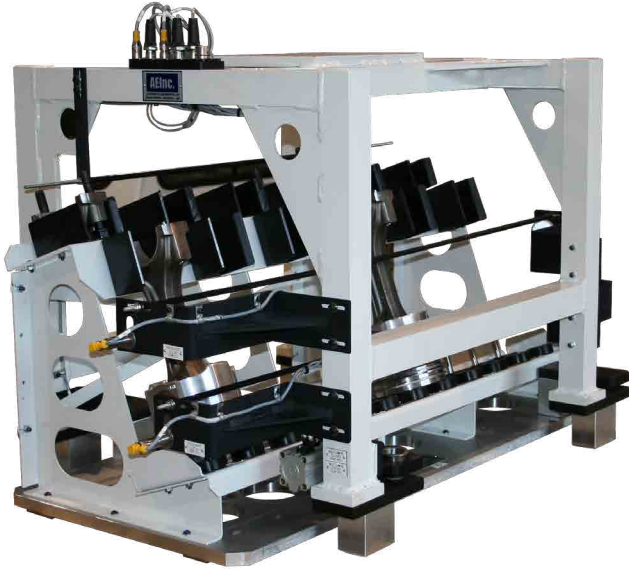

Ring Gear EOAT and Pallet on Hand-Off Stand

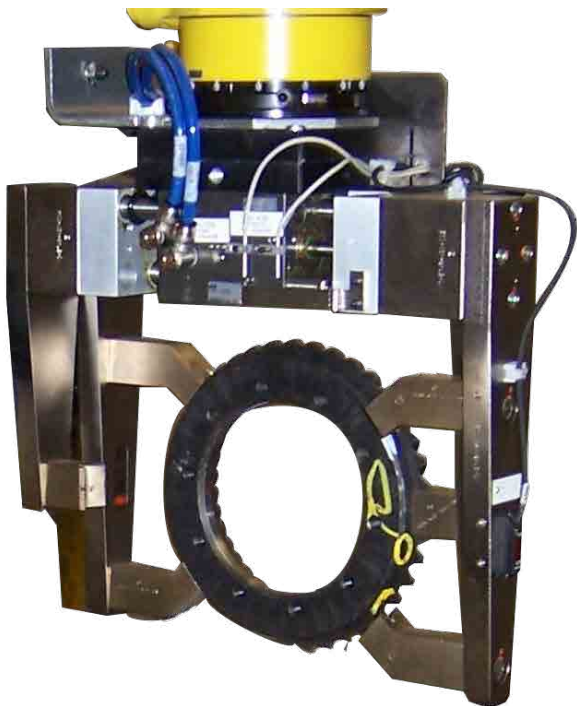

Differential Assembly Dial Table

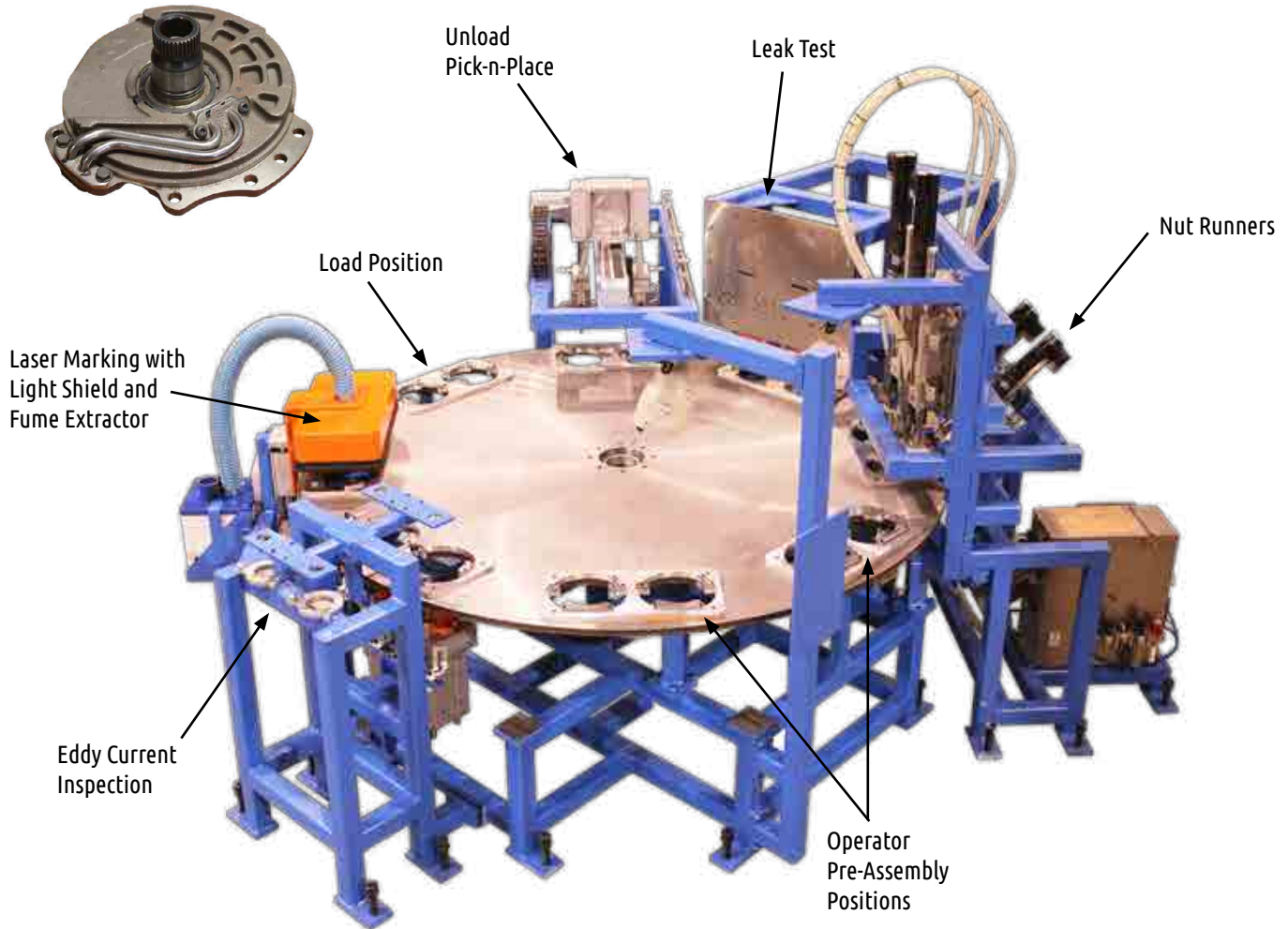

Telesis Part Marking Dial Table with Vision Inspection



Complete Inspection Cell with Part Stamp and Pull-Out Keyboard Trays

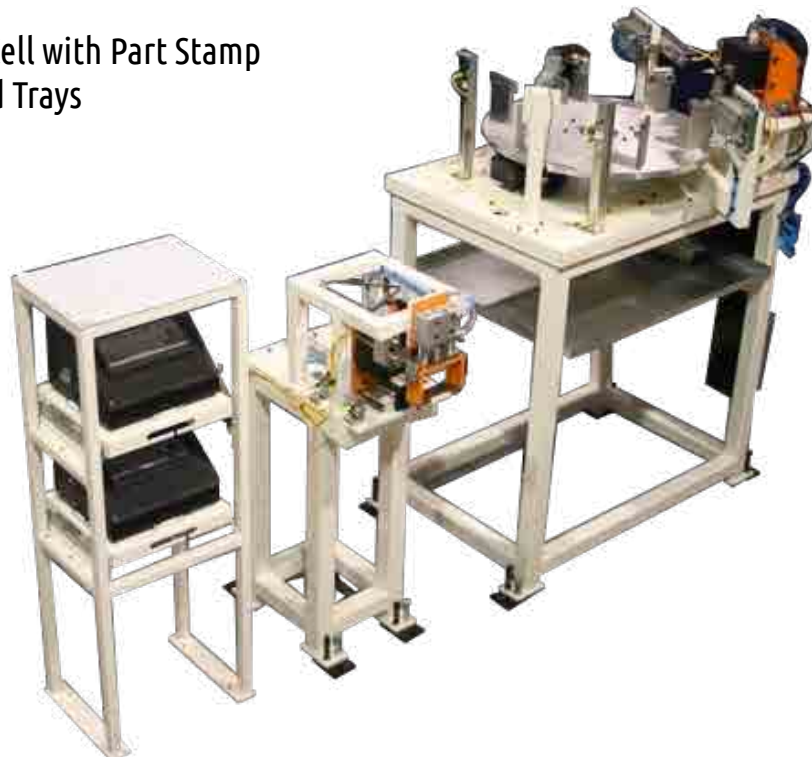

6-Axis Inspection Device Integrated into Roller Conveyor

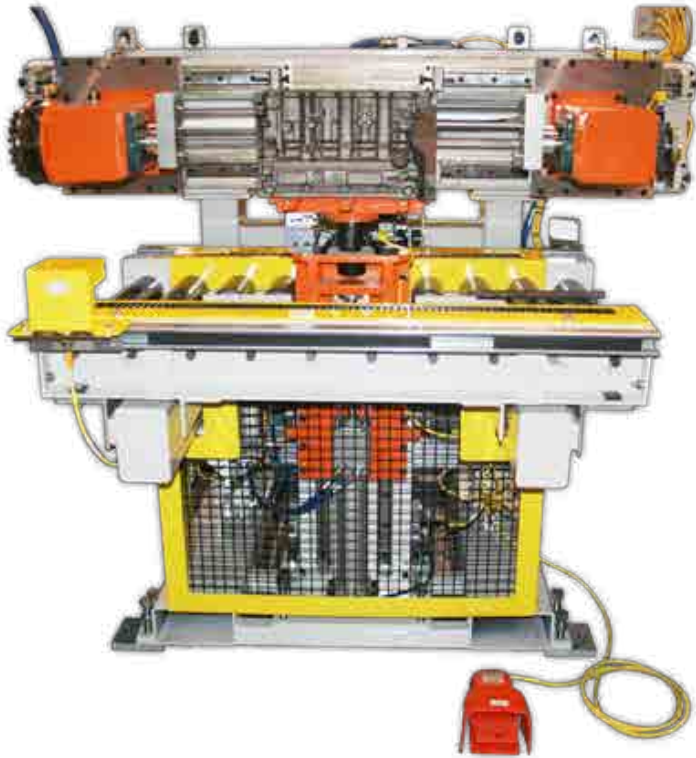

Device Allows Operator to Inspect All Sides of a Cast Engine Block

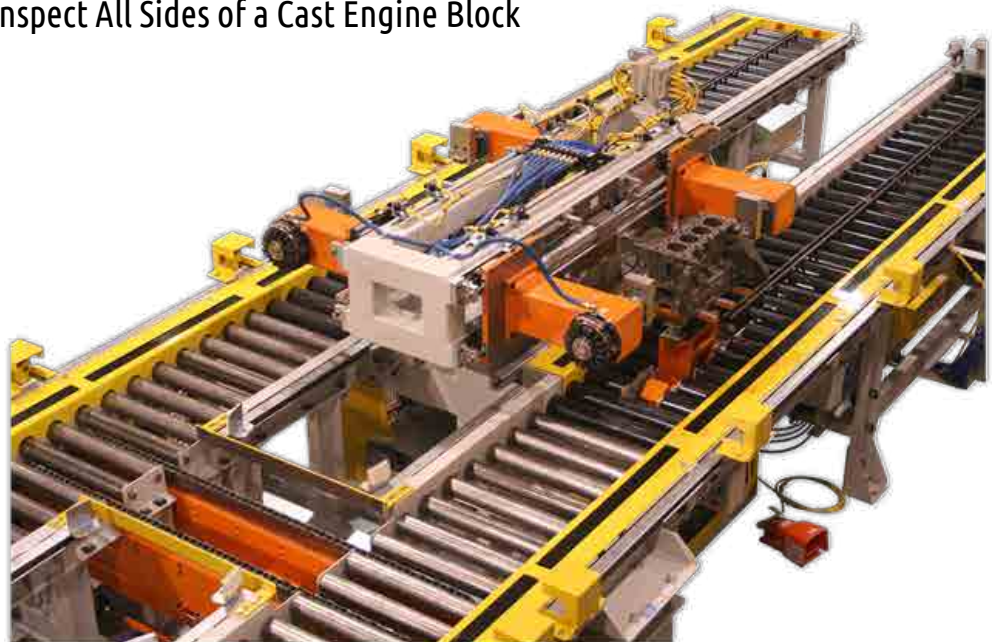

Large Engine Block Inspection Roll-Over Device



4,000 Pound Engine on Precision Pallet



Rotates Palletized Cast Engine Block 90° for Inspection



Alternative Engineering, Inc.

In the distribution and robotic integrator arena, we are a specialist.

We focus on producing a functional and cost efficient solution for each customer's unique situation.



How We are Different

We analyze your system requirements and deliver an innovative solution by suggesting improvements or alternatives to your proposed system.

Our goal is to create machines that are time and cost efficient in order to achieve lean production goals.

We design, build, and test all equipment in house to ensure they are built to last.

Contact Us!

📞 616.785.7200

✉️ sales@aeinc.com

🌐 aeinc.com

📍 5670 West River Drive
Belmont, MI 49306

Bring us your design challenge...

We've designed thousands of solutions, including:

- Robotic Interface Equipment
- Specialty Conveyors
- Factory Accessories
- Spiral Chutes
- Manual Storage & Retrieval Systems
- Battery Cable Booms

