



Empower your mobile workforce to achieve more with innovative, rugged technologies.

RuggedTabletPC.com



Find mobile solutions as unique as your business with MobileDemand's rugged tablets and cases, productivity accessories and software.

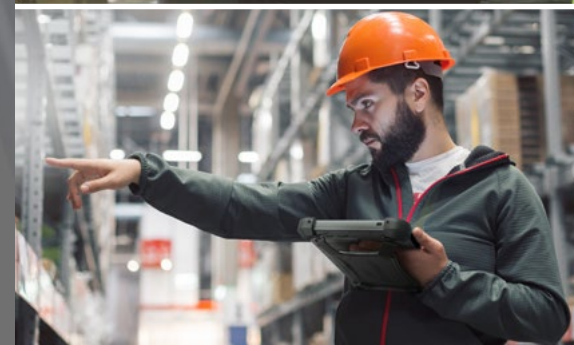
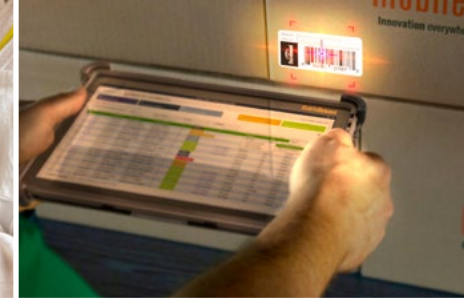
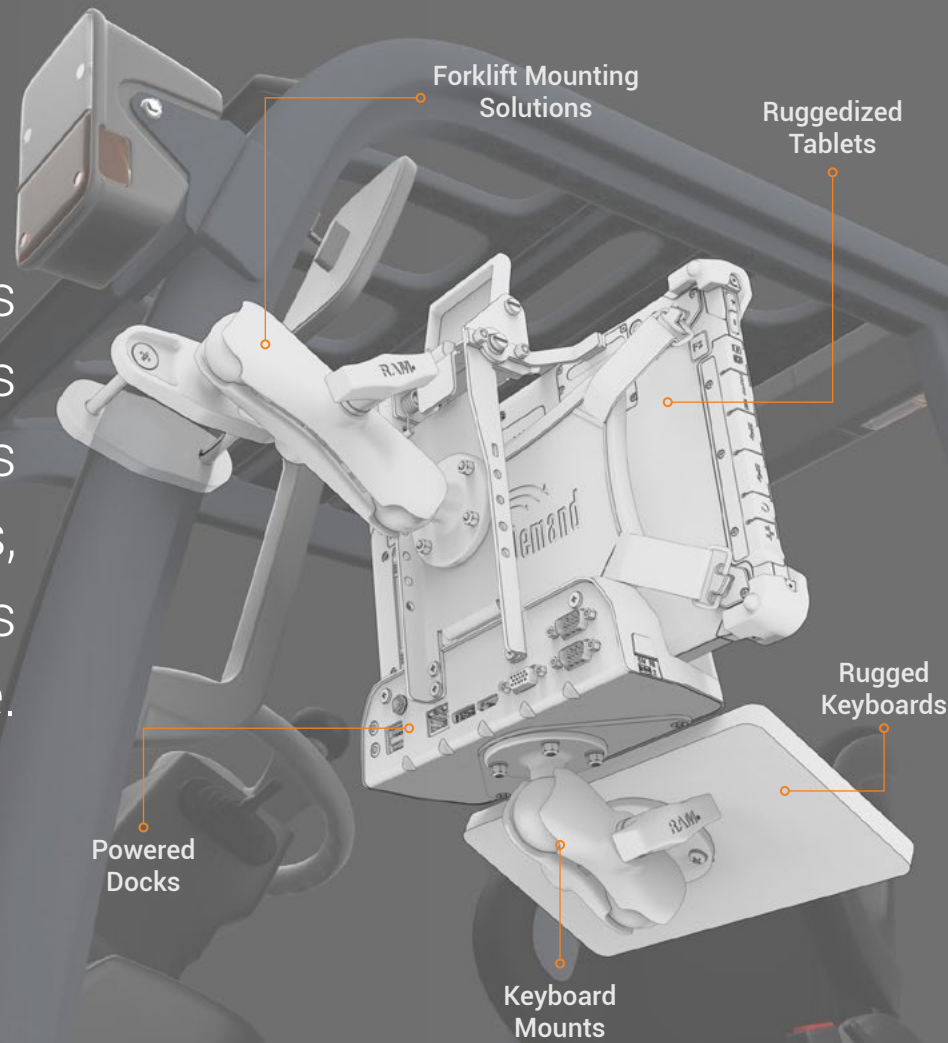

Rugged xCases

Get the ultimate protection and productivity solutions.

Protect world-class manufacturers' tablets with a rugged xCase. Cases pass military drop test standards and include an easy-carry briefcase handle and back hand strap along with our patented snap plate for unlimited mounting options.

 Microsoft Surface
  Lenovo
  iPad
  SAMSUNG

Brand	Available xCase Tablet Models							
Surface Pro	4	5	5LTE	6	7	7+	8	9
Surface Go	Go	Go 2	Go 3					
Lenovo	Tab K10							
Apple iPad	Mini 7.9	Mini 8.3	9.7	10.2	Pro 10.5	Air 10.5	Pro 11	
Samsung	Tab Active3		Tab Active Pro	Tab Active4 Pro				



Surface xtras

Designed for
 Microsoft Surface

Achieve more with Surface.

Expand productivity with our line of Microsoft Designed for Surface® (DfS) certified rugged xCases.

Productivity tools include:

- ▶ Barcode Scanners
- ▶ Magstripe Readers
- ▶ 3D Cameras
- ▶ Payment Brackets



Mounting+Power

Increase workspace efficiency with a patented, durable, quick-release snap mount system that allows for safe and secure mounting nearly anywhere.



Supply Kits

Work continuously with forklift and vehicle-mounted tablets wired directly to the onboard power supply.





Payments. Anywhere.

Mobile Point-of-Sale Solutions for any environment.

Payment Brackets



Verifone e285



Ingenico iSMP4



Ingenico Link/2500



Ingenico Link/2500i

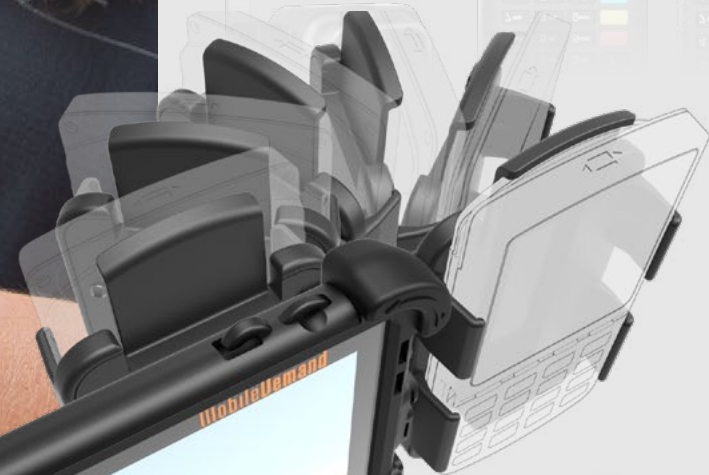

Configure a variety of rugged devices with these popular payment modules.

Powered by **MAGTEK**® **Verifone**® **ingenico**

Mobile Dimensioning



Collect small to large box dimensions in just seconds.



Optimize Space



Increase Workflow Efficiencies



Reduce Costs

Capture accurate box dimensions anywhere with xDIM. The portable, point and click dimensioning software runs on the MobileDemand rugged xTablet you use every day.



xScale

Easily capture weight right at the box.



The Bluetooth-enabled, lightweight, battery-operated xScale 200 complements the xDIM Mobile Dimensioning data collection process.

Custom Innovations

Not finding the right technology for the job?

Our forward-thinking strategy is to design and deliver solutions that fix customer challenges.



About MobileDemand

Since 2003, MobileDemand has been a technology leader in rugged tablets and mobile computing solutions, committed to bringing more functionality and capabilities to the mobile workforce. Specializing in the design of integrated productivity tools for barcode scanning, point of sale, magnetic stripe reading, PIN pad entry, 3D and thermal imaging, box dimension measurement, and mounting hardware for a myriad of on-the-go applications, the company is driving the future of mobile productivity.

4DMobile, a companion company of MobileDemand, develops game-changing software such as xDIM Mobile Dimensioning with a mission to elevate workforce productivity and optimize space with innovative and convenient computer vision and mobile applications.

Learn more at RuggedTabletPC.com



Contact us at Sales@MobileDemand.com 319.363.4121

1501 Boyson Square Drive | Suite 101 | Hiawatha, Iowa 52233