

The **BEAST** SE Series Monorail Hoists

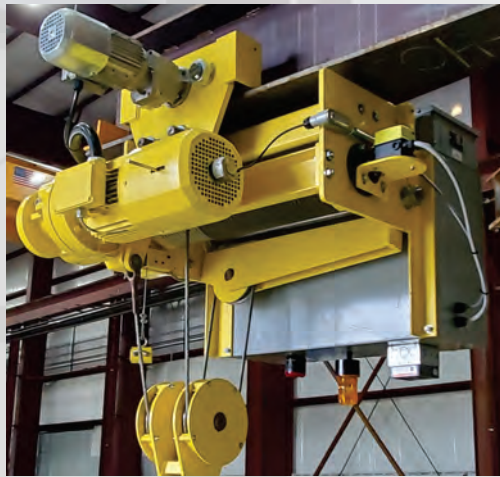

Beast Hoist



Articulating Under Running Long Lift

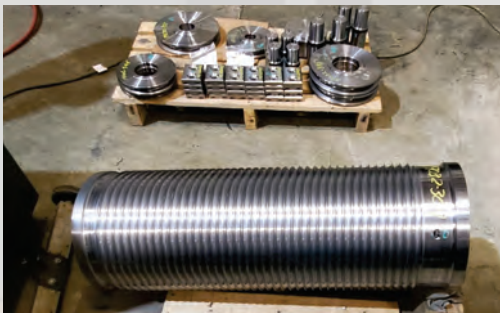

Machined Components



15 Ton Hoist



15 Ton Articulating Trolley Long Lift



Radio Control



Special Applications



Introducing
The **BEAST**

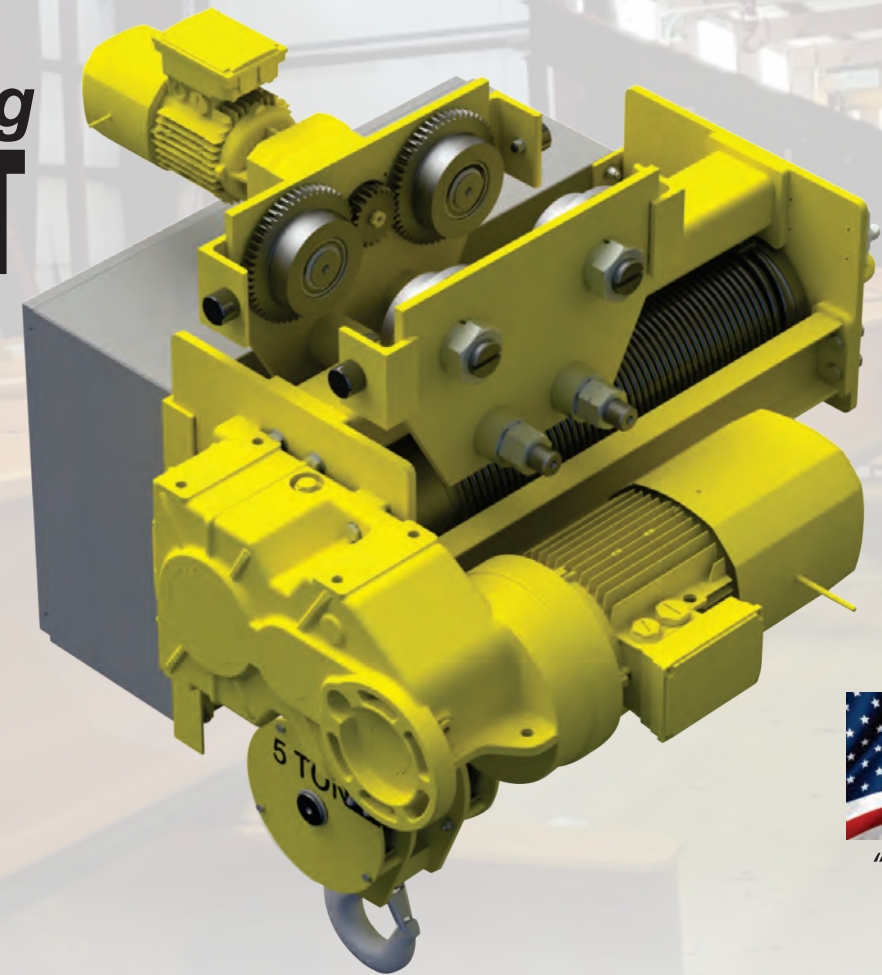

"Buy American"

SE Series Standard Engineered Hoist

AVAILABLE OPTIONS:

- Mainline Contactor and Transformer
- VFD Hoist Control
- Alternate Trolley Speeds
- IP65 Brakes
- Wider Trolley Flange Widths
- Overcapacity Protection
- Pendant Stations / Radio
- Festoon Arm
- UL Panel Labeling

PIEDMONT
HOIST & CRANE
OVERHEAD CRANE SPECIALISTS
3350 Temple School Road
Winston-Salem, NC 27107
(336) 992-1355, Fax (335) 992-2204



WWW.PIEDMONTHOIST.COM

The **BEAST** SE Series Monorail Hoists



Designed and Built in America for Demanding Applications



STANDARD FEATURES:

- 3, 5, 7.5 and 10 ton Capacity
- 2 Speed or VFD Hoist, VFD Trolley
- Engineered and built to exceed ASME H4 Duty
- Space Saving Compact Design
- Built for easy installation and maintenance
- 1 Year Warranty

Ask about:

Series PE and CE Built-Up Hoists available for CMAA applications to 250 Tons through Class F

HOIST AND TROLLEY GEARING

Helical Gearing operating in an oil bath

TROLLEY WHEELS

Crowned Wheels for operation on flat and tapered flanges with lifetime lubricated sealed bearings

HOIST AND TROLLEY MOTORS

TEFC 30-minute Squirrel Cage Motors with Class F Insulation and Adjustable DC Disc Brakes

HOIST AND TROLLEY CONTROLS

Hoist and Trolley Controls mounted in a spacious NEMA 4/12 UL Listed Panel

LIMIT SWITCHES

Geared Upper and Lower Limit Switch plus a Weight Operated Block Activated Limit Switch

BOTTOM BLOCK

Welded steel bottom block with steel sheaves, continuous rotating load hook, and safety latch

DRUM AND REEVING

Minimum 3/8 depth grooving, single reeved with 18:1 drum to rope ratio

