

YOUR NEED. OUR SPEED.

Built on the foundations of our iconic P2000 and P8 systems, the Panther Phantom is the labeling automation solution designed to support your need for speed. Featuring numerous applicator options, this system can be custom-configured to address your company's requirements to achieve maximum throughput. The Phantom is built to run – with agility and flexibility.

A labeling automation solution from Panther Industries will immediately elevate your manufacturing, distribution, and fulfillment processes to realize bottom line benefits through increased throughput, reduced expenses, and decreased waste/loss.

KEY FEATURES

- Built-in Ethernet I/P or Modbus TCP protocols for direct communication with remote host
- Dual automation options (full or semi)
- Zero waste pneumatics – only uses air during operation
- Label application distances up to 24"
- Remote mounted 7" touch screen display
- OEM print engine design for off-the-shelf replacement
- Error reporting for fast, efficient troubleshooting

We design and manufacture every print and apply system for durability and performance, incorporating the following into every Phantom:

Technical Innovation

Numerous applicator configurations available.

Unmatched Construction

1/2" aircraft aluminum main plate and nickel-plated fittings.

Simplified Maintenance

Off-the-shelf replacement parts for efficient serviceability.

Trusted Partner

24/7/365 email and telephone support throughout the system's life.

Contact a Panther sales representative at **800-530-6018** or **sales@print-n-apply.com** to learn how the Phantom can benefit your bottom line.



ACCOMMODATES A 14" ROLL,
WITH A LOW LABEL SENSOR.



REMOTE-MOUNTED 7" TOUCH SCREEN DISPLAY
ALLOWS FOR FLEXIBLE PLACEMENT OPTIONS.



ZERO WASTE PNEUMATICS –
ONLY USES AIR DURING OPERATION.

FEATURES

Controls

- 48 I/O point PLC (expandable up to 56)
- Quick change electrical connections with no hardwiring
- Ethernet I/P or Modbus TCP on the PLC for direct communication with remote host
- Position sensor ensures applicator is home prior to printing a label
- Internal maintenance manual for self-service
- EPC Gen 2 RFID (available with RFID print engine upgrade)
- Low label sensor
- Low ribbon detection

Applicator Options

Completely modular system with multiple configurations:

- Tamp (up to 24" of stroke)
- Swing Arm
- Tamp/Blow
- Inverted Table Top
- Blow On
- Fold
- Wipe On
- Flag
- Merge/Wrap
- Corner Wrap

Additional Features

- Zero waste pneumatics – only uses air during operation
- Auto tamp sensor on all straight tamp applicators (detects contact with a product for a softer, more responsive application)
- Remote mounted 7" touch screen display
- Product detect photo eye
- Reliable waste takeup system with quick-change "O" ring belt drive
- OEM print engine design for off-the-shelf replacement
- Printer interface via HMI
- Simple and efficient label and ribbon loading
- Easy access to air solenoids
- LED indicators on all devices
- Adjustable T-base stand
- Multiple mounting options
- One-year warranty

Customized Options

- Quick-change applicator heads for multiple label sizes
- 80/20 overhead mounting bracket
- 12 – 24 inch stand height extension
- EPC Gen 2 (900MHz) compliant RFID capability

SPECIFICATIONS

Dimensions

30.4" (w) x 26.5" (h) x 24.9" (d)

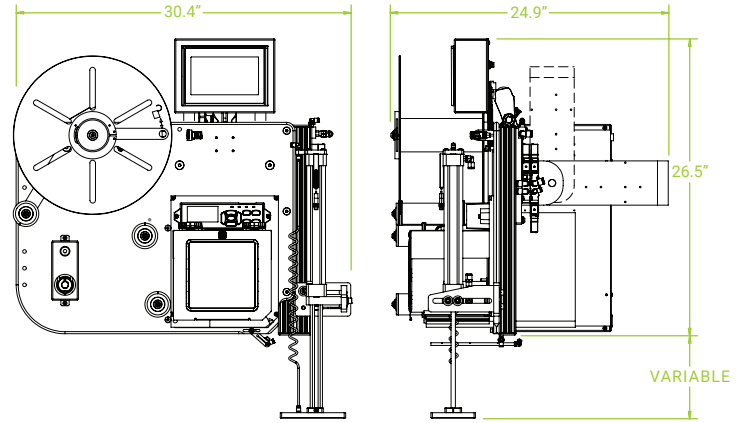

Hardware

Main Plate: 1/2" aircraft aluminum
Fasteners: Nickel-plated and corrosion-resistant
Eurofast sensor connections

Electrical

Input: 115VAC @ 5.0 amps 50/60Hz single phase
Output: 24VDC @ 0.6 amps
Includes 10' power cord

Pneumatics

60 PSI @ 3 CFM (working) / 0 CFM (idle)
OSHA approved lockable shutoff
Filter and regulator included
Push-to-fit connectors throughout
High flow, low pressure pneumatics for safety
Easy, external access to solenoids and filter/regulator

Print Engine

Print Engines: Zebra, SATO, or Honeywell
Print Method: Thermal Transfer or Direct Thermal
Print Width: 6.6" maximum | 0.5" minimum
Print Length: 14" maximum
Print Resolution: 203, 300, or 600* DPI
Media Supply: 14" OD on 3" core
Communication: Serial, Parallel, E-Net, Wireless E-Net, USB

* 600 DPI not available for all print engine manufacturers

Applicator

Placement Accuracy: Within 0.03125"
Maximum Reach: Up to 24" (tamp system)
Up to 30" (swing arm system)