

ID TECHNOLOGY

L&C

LABELING
& CODING

265 WITH CARBONFLEX™ HIGH-SPEED LABEL PRINTER APPLICATOR



Excellence in Secondary Packaging Labeling

The ID Technology 265 print and apply labeling system with CarbonFlex applicator is engineered to apply one or two labels to shipping cases, shrink-wrapped trays, or pallets.

Speed, safety, accuracy, and tolerance of product handling are all critical parts of the CarbonFlex concept.

The ID Technology 265 is the perfect match for CarbonFlex. With its sophisticated Allen-Bradley controls managing the CarbonFlex servo drive and easy-to-use, operator-friendly touch-screen HMI, the 265 is the solution for many secondary packaging applications.

The 265 CarbonFlex is also a good solution for pallet labeling, featuring the ability to apply one or two labels without the pallet needing to slow or stop.

FEATURES AND BENEFITS

- Designed to apply one or two labels to shipping cases, shrink-wrapped trays or pallets.
- Allen-Bradley PLC controls.
- Multiple communication protocols for line integration.
- Servo-controlled, carbon fiber label application blade.
- All-electric - no compressed air needed.
- Less sensitive to inconsistent product handling than other applicator types.
- Engineered for high-speed packaging lines.
- Modular components for maximum serviceability.
- Zero downtime option featuring redundant labeling heads for continuous labeling production.
- Built-in safety - applicator reverses direction on contact and greatly reduces potential pinch points.

COMMON APPLICATIONS



STANDARD PRODUCT SPECIFICATIONS

| | | | | |
|-------------------------|-------------------------------------------|--------------|-------------------|-----------------------------------------|
| Label Supply | 14" Diameter / 3" Core | | Electrical | 120V AC @ 6A, 60Hz |
| Label Size | Min: 4" x 2" | Max: 6" x 4" | PLC | Allen-Bradley Micro850 |
| Swing Arm Length | Min: 9" | Max: 25" | Printer | Print Engines From Zebra & Sato |
| Operation | All Electric - No Compressed Air Required | | Conveyor | Optional Integrated Conveyors Available |

CONFIGURATION

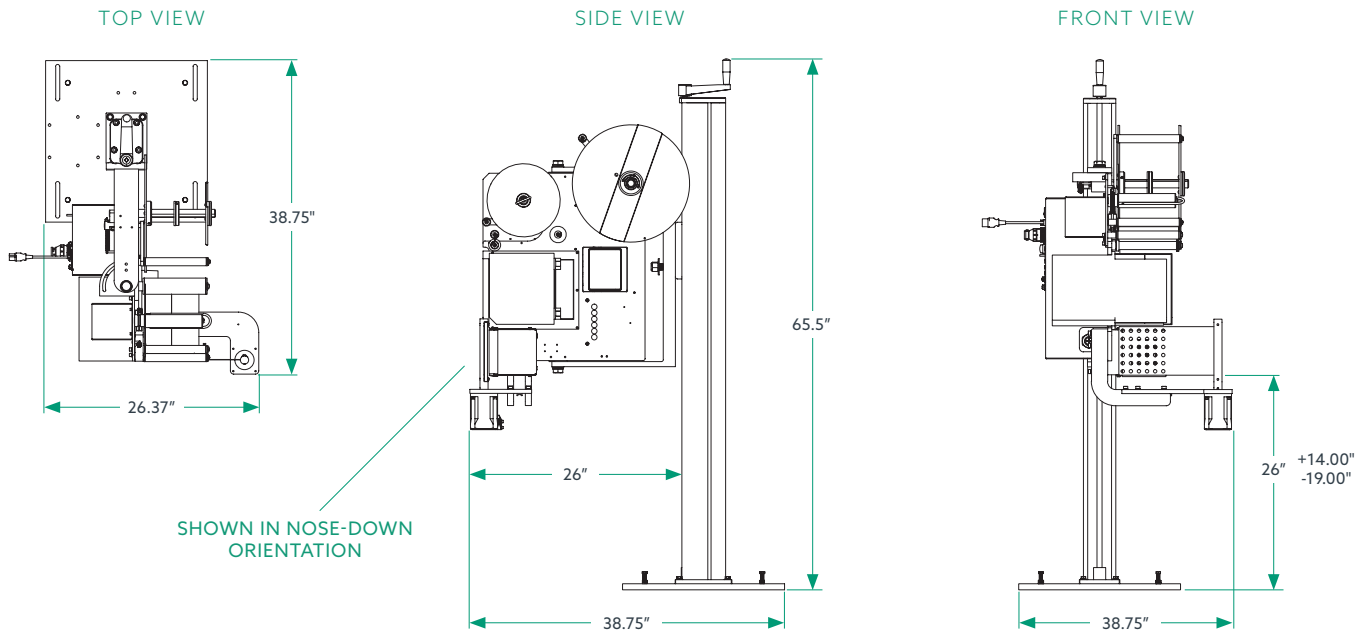

SYSTEM OPTIONS

- Low Label Sensor and Alarm Beacon
- Remote Mounted HMI
- Barcode Scanner
- Various Type of Mounting Hardware
- Integrated Conveyor
- NiceLabel Label Software
- ID Technology NiceLabel Custom Apps
- Windows Based IPC for NiceLabel
- Zero Downtime Option

