

## High Capacity Spiral

Higher Capacity. Small Footprint.



The Ryson High Capacity Spirals are larger and more robust than our standard Spirals, with the same small footprint. They are ideal for conveying larger and heavier loads to greater heights. They are commonly used for heavier items, varied product sizes and where overhead space is used to maximize space utilization.

### Easy to Install:

Most spirals are shipped in one piece, pre-assembled and pre-tested, drastically reducing time and cost of installation.

### Single Drive:

Our efficient rolling friction chain-slat design only needs a single drive - regardless of height or payload - resulting in substantial savings in energy, controls and systems integration.

### Low Maintenance:

Our Spirals and components are designed for reliability, low maintenance and long life. They have an impressive up-time record reducing the total cost of ownership

### Built-in Protection:

All Ryson Spirals are equipped with an automatic chain tensioning device and built-in overload protection ensuring safe and reliable operation.

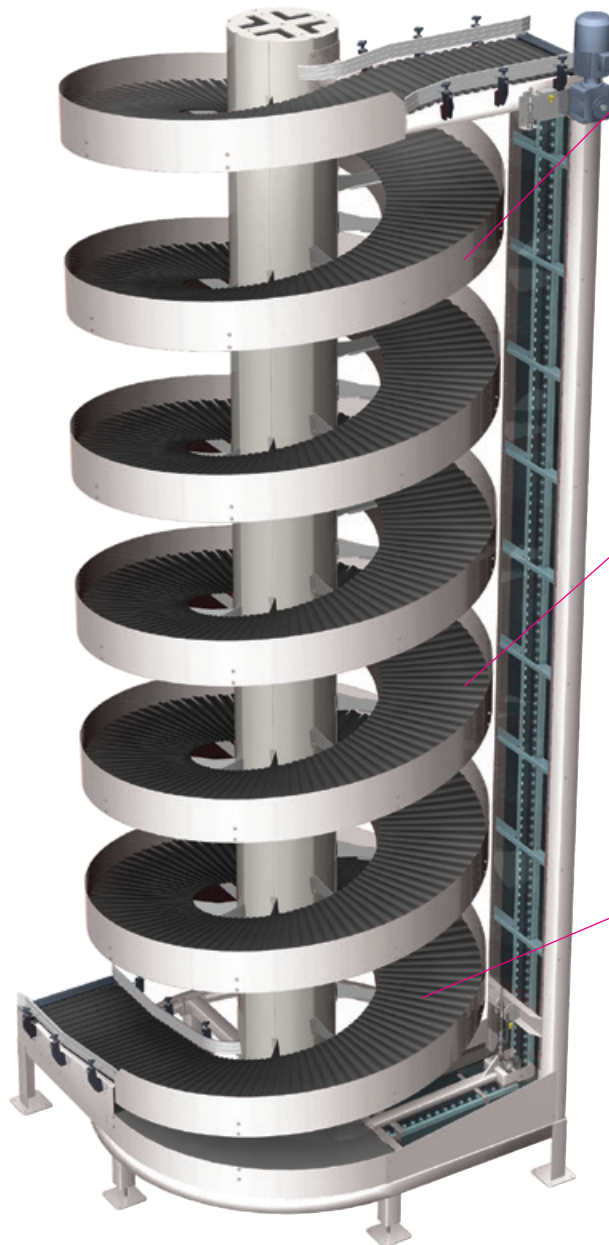

### Multi-level options:

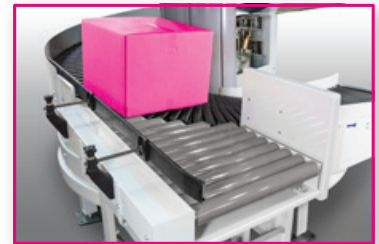

These models can be configured to allow loads to enter or exit the spiral at intermediate levels - Ideal for pick modules and multiple production lines.

### Proprietary Belt Slat:

Our innovative chain-slat design enables a low friction operation without any sliding movements or wear-strips. Our high capacity 1" chain yields a total load capacity of up to 3600 lbs, and can start and stop fully loaded.

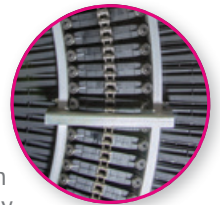

### Overlapping Slats:



16" or 24" wide overlapping slats provide a smooth and efficient conveying surface, with gentle product handling, suitable for all types of conveyable items.

**Controls and Integration:** Most Spirals are shipped without controls because they typically integrate with an overall conveyor control system. We do offer a number of controls and pre-wiring options. A Variable Frequency Drive (VFD) is required for proper operation of the spirals.



Scan or Click  
for full details



### Quick Facts:

Top Speed:	200 FPM
Max Height:	50"
Slat Width:	16" & 24"
Weight Capacity:	75 lbs/lin foot
Total Weight:	Up to 3600 lbs
VFD Required:	Yes
Optional Controls:	Yes
Custom Options:	Yes
Color Options:	RAL colors
Incline Angle:	Up to 12.5°

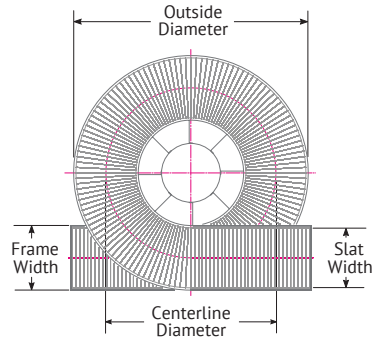

### Configurations:

All Ryson Spiral Conveyors are available in several standard versions to accommodate a wide range of loads and applications.

- The Spiral Conveyors can be configured to go up or down, clockwise or counter-clockwise and can optionally be reversible.
- All models can be built with extended infeed or outfeed tangents, making our Spiral Conveyors an easy to fit and help simplify the most challenging of layouts.

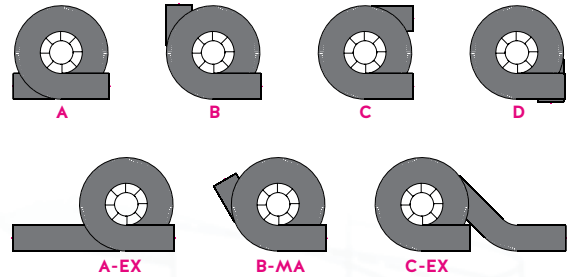

Examples of custom/extended tangents

Type	Outside Diameter	Centerline Diameter	Slat Width	Frame Width
1700-400-HC	7'-3" (2200)	5'-7" (1700)	16" (400)	19" (480)
1700-600-HC	7'-11" (2400)	5'-7" (1700)	24" (600)	27" (680)
2200-760-WT	10'-0" (3050)	7'-3" (2200)	30" (760)	33" (790)
3000-900-WT	13'-0" (3970)	9'-10" (3000)	36" (900)	38" (970)

### Powder Coated Carbon Steel

Part	Specifications
Frame	Coated aluminium tube with galvanized load arms
Chain configuration	Nickel plated chain, carbon steel bearings
Finish	Powder Coated in most RAL colors

### Stainless Steel Hybrid (Dry)

Part	Specifications
Frame	Coated aluminium center tube zinc plated load arms
Chain configuration	Nickel plated chain, carbon steel bearings
Finish	Stainless steel base frame, legs & side guards.

### Stainless Steel (Wet)

Part	Specifications
Frame	Stainless steel or coated aluminium tube depending on model. Stainless steel base frame, load arms & fasteners.
Chain configuration	Nickel plated chain with stainless steel sealed bearings
Finish	Stainless steel base frame, legs & side guards.

### Typically Conveys:

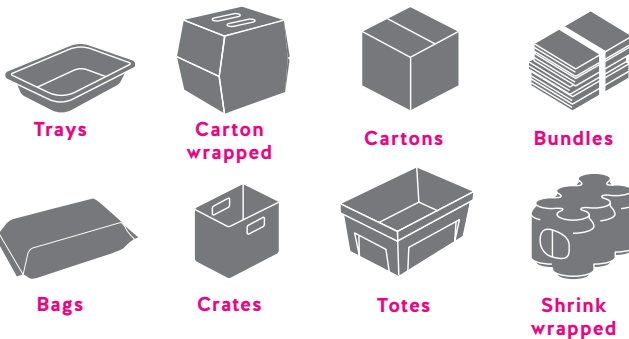

## VERTICAL CONVEYING SOLUTIONS. WORLDWIDE.

Ryson is a member of the Royal Apollo Group, established in 1847 and headquartered in the Netherlands. Ryson manufactures in USA and supports North America. We have manufacturing in Netherlands, USA, and Thailand with service operations in Netherlands, USA, Thailand, China, India, and Mexico. As one global company, we are the world's leader in Vertical Conveying!

