



# **WORKPLACE SHELVING STORAGE RACKS SHOP FURNITURE & SPECIALTY STORAGE**

*Look to Tri-Boro for:*

*Outstanding Quality  
Affordable Pricing  
& Ontime Delivery*

**Online PDF Catalog Pages**

**Tri-Boro Shelving and Partition Corp.**  
300 Dominion Drive • Farmville, VA 23901  
Toll Free: 1-800-633-3070  
Phone: 434-315-5600  
Fax: 434-315-0139

**Tri-Boro Shelving & Partition Corporation**  
296 Wythe Avenue • Brooklyn, N.Y. 11211  
Phone: 718-782-8527  
Fax: 718-963-0457

**[www.triboroshelving.com](http://www.triboroshelving.com)  
e-mail: [info@triboroshelving.com](mailto:info@triboroshelving.com)**

# Tri-Boro Shelving Features

Tri-Boro Shelving is manufactured in the widest range of sizes available in the industry. When used in combination this array of sizes can meet the most demanding of custom applications.

The flanged shelf is manufactured from cold rolled steel and has "Triple Bends" on all four sides for incomparable strength.

**Standard shelves are manufactured in 24", 30", 36", 42" and 48" widths, and 9", 12", 15", 16", 18", 21", 24", 30", 32" and 36" depths.**

All Tri-Boro steel components receive a rust resistant phosphatized cleaning for better paint adhesion and durability. A custom, quality blended powder coat paint is applied "Electro-Statically" and then baked on in a continuous curing oven for lasting durability and outstanding appearance. This process is the latest innovation for the integrity of paint surface and the protection of our environment.

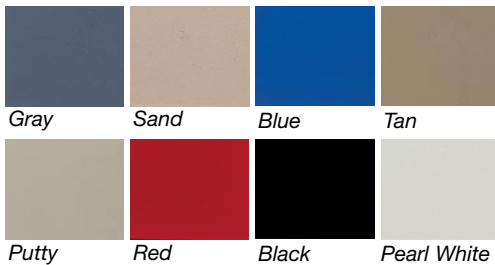

## STANDARD FINISHES

Tri-Boro's standard finish is the Gray Enamel (Shown above). However, all colors shown above are available for a small additional charge. The choice of an alternate color may create a slight delay in delivery.

## SHELF TYPES

### Flange Shelf

**Class 0 – No Re-Bar**



**Class 1 – 1 Re-Bar**



**Class 2 – 2 Re-Bar**



**Flange Shelves** are available in both 20 GA. and 18 GA. material thickness. Class 0 is designed for applications that do not require extreme load bearing strength. The addition of 1 Re-Bar will increase bearing strength by about 50%. The addition of 2 Re-Bars will increase the bearing strength by over 100%. Please see the chart on page 6 for exact load bearing strengths.

## SHELF TYPES (Cont'd)

### Boxer Shelf

**Boxer Shelves** are constructed of 22, 20 or 18 gauge steel with full welded box formation in front and back of the shelf and have formed channels on both ends. All corners are lapped and welded for additional strength. The box formation is welded on a 6" center minimum to provide integrity the entire length of the box. All shelves have a box profile height of 1-1/4". All box shelves accommodate either clip or nut and bolt connection to the upright. Please see the chart on page 6 for exact load bearing strengths.



Tri-Boro's "Boxer"™ industrial grade steel shelving features a welded tubular box design with lapped and welded seam corners.

## POST TYPES

Tri-Boro manufactures rigid roll formed "Box" and companion "Offset Angle" type posts.

The box post provides unobstructed shelf access. One box post takes the place of two angle posts at the front of a shelving unit.

The offset angle post reduces shelf accessibility by 1 inch per end, although the field length is nominal to the dimension ordered.

Box style post heights range from 3'1" to 12'1". Offset Angle heights range from 3'1" to 16'1".

Both styles are manufactured in 1 foot increments. All posts are 14 gauge steel. Shelves can be either clipped or nut & bolted to the post.



Box Post  
Holes 1-1/2" O.C.



Offset Angle Post  
Holes 1-1/2" O.C.



Rolled Formed Angle Post  
Holes 1" O.C.



Offset Angle Post  
Holes 1" O.C.



Government Post  
Holes 1" O.C.

# Tri-Boro Shelf Load Capacities

## FLANGE SHELVES LOAD CAPACITY COMPARISON CHART

Shelf Size	Plain 20 GA.	Plain 18 GA.	1 Rebar 20 GA.	1 Rebar 18 GA.	2 Rebar 20 GA.	2 Rebar 18 GA.
12" x 36"	400	775	700	950	950	1250
12" x 42"	350	550	550	650	800	1100
12" x 48"	300	450	450	575	600	700
15" x 36"	400	750	700	900	950	1150
15" x 42"	325	525	550	750	750	900
15" x 48"	300	450	450	575	575	700
18" x 36"	400	750	700	875	950	1100
18" x 42"	300	500	550	750	750	850
18" x 48"	275	425	450	550	575	700
24" x 36"	400	700	700	850	950	1050
24" x 42"	300	500	550	700	700	850
24" x 48"	275	375	400	475	500	600
30" x 36"	300	550	650	675	800	900
30" x 42"	275	450	500	700	700	850
30" x 48"	225	350	350	450	450	525
36" x 36"	275	450	500	550	575	700
36" x 42"	275	450	450	550	550	600
36" x 48"	225	350	325	425	425	500

## FLANGE SHELF



- TRIPLE BENDS ALL FOUR SIDES
- 10 DEPTHS
- 5 WIDTHS
- 20 GA. AND 18 GA.

## BOXER™ (BOX SHELF)



- FULL WELDED BOX FORMATION (FRONT AND BACK)
- 7 DEPTHS
- 5 WIDTHS
- 22 GA., 20 GA. AND 18 GA.

## BOXER™ SHELVES LOAD CAPACITY COMPARISON CHART

Size	22 GA Capacity	20 GA Capacity	18 GA Capacity
12" x 36"	600	850	1100
12" x 42"	450	650	900
12" x 48"	400	550	750
15" x 36"	600	825	1100
15" x 42"	450	625	900
15" x 48"	400	600	850
18" x 36"	600	850	1200
18" x 42"	500	650	950
18" x 48"	400	550	900
21" x 36"	600	850	1250
21" x 42"	450	650	1000
21" x 48"	375	550	900
24" x 36"	550	850	1200
24" x 42"	450	650	1000
24" x 48"	375	550	900
30" x 36"	500	650	1200
30" x 42"	400	625	900
30" x 48"	375	500	750
36" x 36"	400	550	900
36" x 42"	350	525	850
36" x 48"	325	500	750

# Tri-Boro Hinged Doors for Shelving

## FEATURES

**NEW!**

- HINGED DOORS CONSTRUCTED OF DURABLE 20 GAUGE STEEL, 13 GAUGE FRAME
- DOORS EQUIPPED WITH THREE-POINT LOCKING DEVICE, OPEN 180 DEGREES
- 85" H & 73" H DOORS HAVE A PAN REINFORCEMENT, SPOT WELDED ON EACH SIDE
- TOP AND BOTTOM LOCKING ROD CHANNELS
- EASY TO INSTALL! DOORS PRE-ASSEMBLED AND READY TO INSTALL
- INCLUDED: STANDARD SATIN CHROME FINISHED HANDLE WITH LOCK & 2 KEYS
- DOORS WILL FIT OFFSET & ROLLED-FORMED POSTS



**HD3685**  
36" W x 85" H

Standard Doors Available in 3 Heights: 37", 73" & 85" (Special Sizes upon Request)

Catalog No.	W x H	Wt. (lbs.)
HD3637	36" x 37"	35.0
HD3673	36" x 73"	65.0
HD3685	36" x 85"	70.0
HDK2	Extra Key	

**HD3673**  
36" W x 73" H



**HD3637**  
36" W x 37" H



# Tri-Boro Starter and Add-On Shelving Configurations



Cross Braces on both sides indicates starter



## 7 SHELVES

36" WIDE x 7' 1" HIGH

Depth	Starter Unit No.	Add On Unit No.
12" →	OSB 85-1236-7	OAB 85-1236-7
15"	OSB 85-1536-7	OAB 85-1536-7
18"	OSB 85-1836-7	OAB 85-1836-7
24"	OSB 85-2436-7	OAB 85-2436-7
30"	OSB 85-3036-7	OAB 85-3036-7

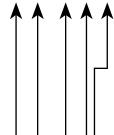

### Unit Type

- B=Boxer
- K=Klip-It
- T=Thunderbolt

### Unit Height

### Unit Depth

### Unit Width

### Number of Shelves

## OS OPEN TYPE STARTER UNIT

Each OS unit is complete consisting of:

- Open Type - Starting Unit
- Any number of shelves
- Four uprights
- Two pair of side sway braces
- One pair of back sway braces
- Necessary nuts and bolts or clips

## OA OPEN TYPE ADD-ON UNIT

Each OA unit is complete consisting of:

- Open Type - Additional Unit
- Any number of shelves
- Four uprights
- One pair of back sway braces
- One pair of side sway braces
- Necessary nuts and bolts or clips



Sides on both ends indicates starter



## 7 SHELVES

36" WIDE x 7' 1" HIGH

Depth	Starter Unit No.	Add On Unit No.
12" →	CSB 85-1236-7	CAB 85-1236-7
15"	CSB 85-1536-7	CAB 85-1536-7
18"	CSB 85-1836-7	CAB 85-1836-7
24"	CSB 85-2436-7	CAB 85-2436-7
30"	CSB 85-3036-7	CAB 85-3036-7

## CS CLOSED TYPE STARTER UNIT

Each CS unit is complete consisting of:

- Closed Type - Starting Unit
- Any number of shelves
- Four uprights
- Two closed sides
- One closed back
- One base
- Necessary nuts and bolts or clips

## CA CLOSED TYPE ADD-ON UNIT

Each CA unit is complete consisting of:

- Closed Type - Additional Unit
- Any number of shelves
- Four uprights
- One closed side
- One closed back
- One base
- Necessary nuts and bolts or clips

# Tri-Boro Open & Closed Type Shelving Units



Note: Dimensions are for posts 1-1/2" on centers – Dimensions for posts on 1" centers will be different.

**WHEN ORDERING: The first 3 letters in the Starter Unit Order Number Indicate Open Or Closed; Starter Unit or Add-on Unit; Boxer, Thunderbolt or Klip-It**

**NOTE: Add 2" to the height of each unit for Thunderbolt, i.e. 6'1" Boxer & Klip-It = 6'3" Thunderbolt**

Shelving Units Also Available With New Offset Posts 1" On Centers (See Page 11) and New Clip (See Page 16)

**6' 1" HIGH OPEN TYPE • BOXER™ (BOX-SHELF): 22 GA., 20 GA. and 18 GA.**

UNIT NUMBERS ON THIS PAGE ARE 20 GA. – ADD L FOR 22 GA., X FOR 18 GA.

OSB 73-1236-5 **Unit Type**  
 B=Boxer  
 K=Klip-It  
 T=Thunderbolt

Note: 36" Deep Shelving Available.  
 See price list for components

**5 SHELVES 36" WIDE x 6' 1" HIGH**

Depth	Starter Unit No.	Add On Unit No.
12"	OSB 73-1236-5	OAB 73-1236-5
15"	OSB 73-1536-5	OAB 73-1536-5
18"	OSB 73-1836-5	OAB 73-1836-5
24"	OSB 73-2436-5	OAB 73-2436-5
30"	OSB 73-3036-5	OAB 73-3036-5

**6 SHELVES 36" WIDE x 6' 1" HIGH**

Depth	Starter Unit No.	Add On Unit No.
12"	OSB 73-1236-6	OAB 73-1236-6
15"	OSB 73-1536-6	OAB 73-1536-6
18"	OSB 73-1836-6	OAB 73-1836-6
24"	OSB 73-2436-6	OAB 73-2436-6
30"	OSB 73-3036-6	OAB 73-3036-6

**7 SHELVES 36" WIDE x 6' 1" HIGH**

Depth	Starter Unit No.	Add On Unit No.
12"	OSB 73-1236-7	OAB 73-1236-7
15"	OSB 73-1536-7	OAB 73-1536-7
18"	OSB 73-1836-7	OAB 73-1836-7
24"	OSB 73-2436-7	OAB 73-2436-7
30"	OSB 73-3036-7	OAB 73-3036-7

**42" WIDE x 6' 1" HIGH**

Depth	Starter Unit No.	Add On Unit No.
12"	OSB 73-1242-5	OAB 73-1242-5
15"	OSB 73-1542-5	OAB 73-1542-5
18"	OSB 73-1842-5	OAB 73-1842-5
24"	OSB 73-2442-5	OAB 73-2442-5
30"	OSB 73-3042-5	OAB 73-3042-5

**42" WIDE x 6' 1" HIGH**

Depth	Starter Unit No.	Add On Unit No.
12"	OSB 73-1242-6	OAB 73-1242-6
15"	OSB 73-1542-6	OAB 73-1542-6
18"	OSB 73-1842-6	OAB 73-1842-6
24"	OSB 73-2442-6	OAB 73-2442-6
30"	OSB 73-3042-6	OAB 73-3042-6

**42" WIDE x 6' 1" HIGH**

Depth	Starter Unit No.	Add On Unit No.
12"	OSB 73-1242-7	OAB 73-1242-7
15"	OSB 73-1542-7	OAB 73-1542-7
18"	OSB 73-1842-7	OAB 73-1842-7
24"	OSB 73-2442-7	OAB 73-2442-7
30"	OSB 73-3042-7	OAB 73-3042-7

**48" WIDE x 6' 1" HIGH**

Depth	Starter Unit No.	Add On Unit No.
12"	OSB 73-1248-5	OAB 73-1248-5
15"	OSB 73-1548-5	OAB 73-1548-5
18"	OSB 73-1848-5	OAB 73-1848-5
24"	OSB 73-2448-5	OAB 73-2448-5
30"	OSB 73-3048-5	OAB 73-3048-5

**48" WIDE x 6' 1" HIGH**

Depth	Starter Unit No.	Add On Unit No.
12"	OSB 73-1248-6	OAB 73-1248-6
15"	OSB 73-1548-6	OAB 73-1548-6
18"	OSB 73-1848-6	OAB 73-1848-6
24"	OSB 73-2448-6	OAB 73-2448-6
30"	OSB 73-3048-6	OAB 73-3048-6

**48" WIDE x 6' 1" HIGH**

Depth	Starter Unit No.	Add On Unit No.
12"	OSB 73-1248-7	OAB 73-1248-7
15"	OSB 73-1548-7	OAB 73-1548-7
18"	OSB 73-1848-7	OAB 73-1848-7
24"	OSB 73-2448-7	OAB 73-2448-7
30"	OSB 73-3048-7	OAB 73-3048-7

**6' 1" HIGH CLOSED TYPE • BOXER™ (BOX-SHELF): 22 GA., 20 GA. and 18 GA.**

UNIT NUMBERS ON THIS PAGE ARE 20 GA. – ADD L FOR 22 GA., X FOR 18 GA.

**5 SHELVES 36" WIDE x 6' 1" HIGH**

Depth	Starter Unit No.	Add On Unit No.
12"	CSB 73-1236-5	CAB 73-1236-5
15"	CSB 73-1536-5	CAB 73-1536-5
18"	CSB 73-1836-5	CAB 73-1836-5
24"	CSB 73-2436-5	CAB 73-2436-5
30"	CSB 73-3036-5	CAB 73-3036-5

**6 SHELVES 36" WIDE x 6' 1" HIGH**

Depth	Starter Unit No.	Add On Unit No.
12"	CSB 73-1236-6	CAB 73-1236-6
15"	CSB 73-1536-6	CAB 73-1536-6
18"	CSB 73-1836-6	CAB 73-1836-6
24"	CSB 73-2436-6	CAB 73-2436-6
30"	CSB 73-3036-6	CAB 73-3036-6

**7 SHELVES 36" WIDE x 6' 1" HIGH**

Depth	Starter Unit No.	Add On Unit No.
12"	CSB 73-1236-7	CAB 73-1236-7
15"	CSB 73-1536-7	CAB 73-1536-7
18"	CSB 73-1836-7	CAB 73-1836-7
24"	CSB 73-2436-7	CAB 73-2436-7
30"	CSB 73-3036-7	CAB 73-3036-7

**42" WIDE x 6' 1" HIGH**

Depth	Starter Unit No.	Add On Unit No.
12"	CSB 73-1242-5	CAB 73-1242-5
15"	CSB 73-1542-5	CAB 73-1542-5
18"	CSB 73-1842-5	CAB 73-1842-5
24"	CSB 73-2442-5	CAB 73-2442-5
30"	CSB 73-3042-5	CAB 73-3042-5

**42" WIDE x 6' 1" HIGH**

Depth	Starter Unit No.	Add On Unit No.
12"	CSB 73-1242-6	CAB 73-1242-6
15"	CSB 73-1542-6	CAB 73-1542-6
18"	CSB 73-1842-6	CAB 73-1842-6
24"	CSB 73-2442-6	CAB 73-2442-6
30"	CSB 73-3042-6	CAB 73-3042-6

**42" WIDE x 6' 1" HIGH**

Depth	Starter Unit No.	Add On Unit No.
12"	CSB 73-1242-7	CAB 73-1242-7
15"	CSB 73-1542-7	CAB 73-1542-7
18"	CSB 73-1842-7	CAB 73-1842-7
24"	CSB 73-2442-7	CAB 73-2442-7
30"	CSB 73-3042-7	CAB 73-3042-7

**48" WIDE x 6' 1" HIGH**

Depth	Starter Unit No.	Add On Unit No.
12"	CSB 73-1248-5	CAB 73-1248-5
15"	CSB 73-1548-5	CAB 73-1548-5
18"	CSB 73-1848-5	CAB 73-1848-5
24"	CSB 73-2448-5	CAB 73-2448-5
30"	CSB 73-3048-5	CAB 73-3048-5

**48" WIDE x 6' 1" HIGH**

Depth	Starter Unit No.	Add On Unit No.
12"	CSB 73-1248-6	CAB 73-1248-6
15"	CSB 73-1548-6	CAB 73-1548-6
18"	CSB 73-1848-6	CAB 73-1848-6
24"	CSB 73-2448-6	CAB 73-2448-6
30"	CSB 73-3048-6	CAB 73-3048-6

**48" WIDE x 6' 1" HIGH**

Depth	Starter Unit No.	Add On Unit No.
12"	CSB 73-1248-7	CAB 73-1248-7
15"	CSB 73-1548-7	CAB 73-1548-7
18"	CSB 73-1848-7	CAB 73-1848-7
24"	CSB 73-2448-7	CAB 73-2448-7
30"	CSB 73-3048-7	CAB 73-3048-7

# Tri-Boro Open & Closed Type Shelving Units



Note: Dimensions are for posts 1-1/2" on centers – Dimensions for posts on 1" centers will be different.

**WHEN ORDERING: The first 3 letters in the Starter Unit Order Number Indicate Open Or Closed; Starter Unit or Add-on Unit; Boxer, Thunderbolt or Klip-It**

**NOTE: Add 2" to the height of each unit for Thunderbolt, i.e. 7'1" Boxer & Klip-It = 7'3" Thunderbolt**

Shelving Units Also Available With New Offset Posts 1" On Centers (See Page 11) and New Clip (See Page 16)

OSB 73-1236-5 **Unit Type**  
 B=Boxer  
 K=Klip-It  
 T=Thunderbolt

Note: 36" Deep Shelving Available.  
 See price list for components

**7' 1" HIGH OPEN TYPE • BOXER™ (BOX-SHELF): 22 GA., 20 GA. and 18 GA.**

UNIT NUMBERS ON THIS PAGE ARE 20 GA. – ADD L FOR 22 GA., X FOR 18 GA.

5 SHELVES 36" WIDE x 7' 1" HIGH			6 SHELVES 36" WIDE x 7' 1" HIGH			7 SHELVES 36" WIDE x 7' 1" HIGH		
Depth	Starter Unit No.	Add On Unit No.	Depth	Starter Unit No.	Add On Unit No.	Depth	Starter Unit No.	Add On Unit No.
12"	OSB 85-1236-5	OAB 85-1236-5	12"	OSB 85-1236-6	OAB 85-1236-6	12"	OSB 85-1236-7	OAB 85-1236-7
15"	OSB 85-1536-5	OAB 85-1536-5	15"	OSB 85-1536-6	OAB 85-1536-6	15"	OSB 85-1536-7	OAB 85-1536-7
18"	OSB 85-1836-5	OAB 85-1836-5	18"	OSB 85-1836-6	OAB 85-1836-6	18"	OSB 85-1836-7	OAB 85-1836-7
24"	OSB 85-2436-5	OAB 85-2436-5	24"	OSB 85-2436-6	OAB 85-2436-6	24"	OSB 85-2436-7	OAB 85-2436-7
30"	OSB 85-3036-5	OAB 85-3036-5	30"	OSB 85-3036-6	OAB 85-3036-6	30"	OSB 85-3036-7	OAB 85-3036-7
42" WIDE x 7' 1" HIGH			42" WIDE x 7' 1" HIGH			42" WIDE x 7' 1" HIGH		
Depth	Starter Unit No.	Add On Unit No.	Depth	Starter Unit No.	Add On Unit No.	Depth	Starter Unit No.	Add On Unit No.
12"	OSB 85-1242-5	OAB 85-1242-5	12"	OSB 85-1242-6	OAB 85-1242-6	12"	OSB 85-1242-7	OAB 85-1242-7
15"	OSB 85-1542-5	OAB 85-1542-5	15"	OSB 85-1542-6	OAB 85-1542-6	15"	OSB 85-1542-7	OAB 85-1542-7
18"	OSB 85-1842-5	OAB 85-1842-5	18"	OSB 85-1842-6	OAB 85-1842-6	18"	OSB 85-1842-7	OAB 85-1842-7
24"	OSB 85-2442-5	OAB 85-2442-5	24"	OSB 85-2442-6	OAB 85-2442-6	24"	OSB 85-2442-7	OAB 85-2442-7
30"	OSB 85-3042-5	OAB 85-3042-5	30"	OSB 85-3042-6	OAB 85-3042-6	30"	OSB 85-3042-7	OAB 85-3042-7
48" WIDE x 7' 1" HIGH			48" WIDE x 7' 1" HIGH			48" WIDE x 7' 1" HIGH		
Depth	Starter Unit No.	Add On Unit No.	Depth	Starter Unit No.	Add On Unit No.	Depth	Starter Unit No.	Add On Unit No.
12"	OSB 85-1248-5	OAB 85-1248-5	12"	OSB 85-1248-6	OAB 85-1248-6	12"	OSB 85-1248-7	OAB 85-1248-7
15"	OSB 85-1548-5	OAB 85-1548-5	15"	OSB 85-1548-6	OAB 85-1548-6	15"	OSB 85-1548-7	OAB 85-1548-7
18"	OSB 85-1848-5	OAB 85-1848-5	18"	OSB 85-1848-6	OAB 85-1848-6	18"	OSB 85-1848-7	OAB 85-1848-7
24"	OSB 85-2448-5	OAB 85-2448-5	24"	OSB 85-2448-6	OAB 85-2448-6	24"	OSB 85-2448-7	OAB 85-2448-7
30"	OSB 85-3048-5	OAB 85-3048-5	30"	OSB 85-3048-6	OAB 85-3048-6	30"	OSB 85-3048-7	OAB 85-3048-7

**7' 1" HIGH CLOSED TYPE • BOXER™ (BOX-SHELF): 22 GA., 20 GA. and 18 GA.**

UNIT NUMBERS ON THIS PAGE ARE 20 GA. – ADD L FOR 22 GA., X FOR 18 GA.

5 SHELVES 36" WIDE x 7' 1" HIGH			6 SHELVES 36" WIDE x 7' 1" HIGH			7 SHELVES 36" WIDE x 7' 1" HIGH		
Depth	Starter Unit No.	Add On Unit No.	Depth	Starter Unit No.	Add On Unit No.	Depth	Starter Unit No.	Add On Unit No.
12"	CSB 85-1236-5	CAB 85-1236-5	12"	CSB 85-1236-6	CAB 85-1236-6	12"	CSB 85-1236-7	CAB 85-1236-7
15"	CSB 85-1536-5	CAB 85-1536-5	15"	CSB 85-1536-6	CAB 85-1536-6	15"	CSB 85-1536-7	CAB 85-1536-7
18"	CSB 85-1836-5	CAB 85-1836-5	18"	CSB 85-1836-6	CAB 85-1836-6	18"	CSB 85-1836-7	CAB 85-1836-7
24"	CSB 85-2436-5	CAB 85-2436-5	24"	CSB 85-2436-6	CAB 85-2436-6	24"	CSB 85-2436-7	CAB 85-2436-7
30"	CSB 85-3036-5	CAB 85-3036-5	30"	CSB 85-3036-6	CAB 85-3036-6	30"	CSB 85-3036-7	CAB 85-3036-7
42" WIDE x 7' 1" HIGH			42" WIDE x 7' 1" HIGH			42" WIDE x 7' 1" HIGH		
Depth	Starter Unit No.	Add On Unit No.	Depth	Starter Unit No.	Add On Unit No.	Depth	Starter Unit No.	Add On Unit No.
12"	CSB 85-1242-5	CAB 85-1242-5	12"	CSB 85-1242-6	CAB 85-1242-6	12"	CSB 85-1242-7	CAB 85-1242-7
15"	CSB 85-1542-5	CAB 85-1542-5	15"	CSB 85-1542-6	CAB 85-1542-6	15"	CSB 85-1542-7	CAB 85-1542-7
18"	CSB 85-1842-5	CAB 85-1842-5	18"	CSB 85-1842-6	CAB 85-1842-6	18"	CSB 85-1842-7	CAB 85-1842-7
24"	CSB 85-2442-5	CAB 85-2442-5	24"	CSB 85-2442-6	CAB 85-2442-6	24"	CSB 85-2442-7	CAB 85-2442-7
30"	CSB 85-3042-5	CAB 85-3042-5	30"	CSB 85-3042-6	CAB 85-3042-6	30"	CSB 85-3042-7	CAB 85-3042-7
48" WIDE x 7' 1" HIGH			48" WIDE x 7' 1" HIGH			48" WIDE x 7' 1" HIGH		
Depth	Starter Unit No.	Add On Unit No.	Depth	Starter Unit No.	Add On Unit No.	Depth	Starter Unit No.	Add On Unit No.
12"	CSB 85-1248-5	CAB 85-1248-5	12"	CSB 85-1248-6	CAB 85-1248-6	12"	CSB 85-1248-7	CAB 85-1248-7
15"	CSB 85-1548-5	CAB 85-1548-5	15"	CSB 85-1548-6	CAB 85-1548-6	15"	CSB 85-1548-7	CAB 85-1548-7
18"	CSB 85-1848-5	CAB 85-1848-5	18"	CSB 85-1848-6	CAB 85-1848-6	18"	CSB 85-1848-7	CAB 85-1848-7
24"	CSB 85-2448-5	CAB 85-2448-5	24"	CSB 85-2448-6	CAB 85-2448-6	24"	CSB 85-2448-7	CAB 85-2448-7
30"	CSB 85-3048-5	CAB 85-3048-5	30"	CSB 85-3048-6	CAB 85-3048-6	30"	CSB 85-3048-7	CAB 85-3048-7

# Tri-Boro Open & Closed Type Shelving Units



Note: Dimensions are for posts 1-1/2" on centers – Dimensions for posts on 1" centers will be different.

**WHEN ORDERING: The first 3 letters in the Starter Unit Order Number Indicate Open Or Closed; Starter Unit or Add-on Unit; Boxer, Thunderbolt or Klip-It**

**NOTE: Add 2" to the height of each unit for Thunderbolt, i.e. 8'1" Boxer & Klip-It= 8'3" Thunderbolt**

Shelving Units Also Available With New Offset Posts 1" On Centers (See Page 11) and New Clip (See Page 16)

**8' 1" HIGH OPEN TYPE • BOXER™ (BOX-SHELF): 22 GA., 20 GA. and 18 GA.**

UNIT NUMBERS ON THIS PAGE ARE 20 GA. – ADD L FOR 22 GA., X FOR 18 GA.

OSB 73-1236-5 **Unit Type**  
 B=Boxer  
 K=Klip-It  
 T=Thunderbolt

Note: 36" Deep Shelving Available.  
 See price list for components

## 5 SHELVES 36" WIDE x 8' 1" HIGH

Depth	Starter Unit No.	Add On Unit No.
12"	OSB 97-1236-5	OAB 97-1236-5
15"	OSB 97-1536-5	OAB 97-1536-5
18"	OSB 97-1836-5	OAB 97-1836-5
24"	OSB 97-2436-5	OAB 97-2436-5
30"	OSB 97-3036-5	OAB 97-3036-5

## 42" WIDE x 8' 1" HIGH

Depth	Starter Unit No.	Add On Unit No.
12"	OSB 97-1242-5	OAB 97-1242-5
15"	OSB 97-1542-5	OAB 97-1542-5
18"	OSB 97-1842-5	OAB 97-1842-5
24"	OSB 97-2442-5	OAB 97-2442-5
30"	OSB 97-3042-5	OAB 97-3042-5

## 48" WIDE x 8' 1" HIGH

Depth	Starter Unit No.	Add On Unit No.
12"	OSB 97-1248-5	OAB 97-1248-5
15"	OSB 97-1548-5	OAB 97-1548-5
18"	OSB 97-1848-5	OAB 97-1848-5
24"	OSB 97-2448-5	OAB 97-2448-5
30"	OSB 97-3048-5	OAB 97-3048-5

## 6 SHELVES 36" WIDE x 8' 1" HIGH

Depth	Starter Unit No.	Add On Unit No.
12"	OSB 97-1236-6	OAB 97-1236-6
15"	OSB 97-1536-6	OAB 97-1536-6
18"	OSB 97-1836-6	OAB 97-1836-6
24"	OSB 97-2436-6	OAB 97-2436-6
30"	OSB 97-3036-6	OAB 97-3036-6

## 42" WIDE x 8' 1" HIGH

Depth	Starter Unit No.	Add On Unit No.
12"	OSB 97-1242-6	OAB 97-1242-6
15"	OSB 97-1542-6	OAB 97-1542-6
18"	OSB 97-1842-6	OAB 97-1842-6
24"	OSB 97-2442-6	OAB 97-2442-6
30"	OSB 97-3042-6	OAB 97-3042-6

## 48" WIDE x 8' 1" HIGH

Depth	Starter Unit No.	Add On Unit No.
12"	OSB 97-1248-6	OAB 97-1248-6
15"	OSB 97-1548-6	OAB 97-1548-6
18"	OSB 97-1848-6	OAB 97-1848-6
24"	OSB 97-2448-6	OAB 97-2448-6
30"	OSB 97-3048-6	OAB 97-3048-6

## 7 SHELVES 36" WIDE x 8' 1" HIGH

Depth	Starter Unit No.	Add On Unit No.
12"	OSB 97-1236-7	OAB 97-1236-7
15"	OSB 97-1536-7	OAB 97-1536-7
18"	OSB 97-1836-7	OAB 97-1836-7
24"	OSB 97-2436-7	OAB 97-2436-7
30"	OSB 97-3036-7	OAB 97-3036-7

## 42" WIDE x 8' 1" HIGH

Depth	Starter Unit No.	Add On Unit No.
12"	OSB 97-1242-7	OAB 97-1242-7
15"	OSB 97-1542-7	OAB 97-1542-7
18"	OSB 97-1842-7	OAB 97-1842-7
24"	OSB 97-2442-7	OAB 97-2442-7
30"	OSB 97-3042-7	OAB 97-3042-7

## 48" WIDE x 8' 1" HIGH

Depth	Starter Unit No.	Add On Unit No.
12"	OSB 97-1248-7	OAB 97-1248-7
15"	OSB 97-1548-7	OAB 97-1548-7
18"	OSB 97-1848-7	OAB 97-1848-7
24"	OSB 97-2448-7	OAB 97-2448-7
30"	OSB 97-3048-7	OAB 97-3048-7

## 8' 1" HIGH CLOSED TYPE • BOXER™ (BOX-SHELF): 22 GA., 20 GA. and 18 GA.

UNIT NUMBERS ON THIS PAGE ARE 20 GA. – ADD L FOR 22 GA., X FOR 18 GA.

### 5 SHELVES 36" WIDE x 8' 1" HIGH

Depth	Starter Unit No.	Add On Unit No.
12"	CSB 97-1236-5	CAB 97-1236-5
15"	CSB 97-1536-5	CAB 97-1536-5
18"	CSB 97-1836-5	CAB 97-1836-5
24"	CSB 97-2436-5	CAB 97-2436-5
30"	CSB 97-3036-5	CAB 97-3036-5

### 42" WIDE x 8' 1" HIGH

Depth	Starter Unit No.	Add On Unit No.
12"	CSB 97-1242-5	CAB 97-1242-5
15"	CSB 97-1542-5	CAB 97-1542-5
18"	CSB 97-1842-5	CAB 97-1842-5
24"	CSB 97-2442-5	CAB 97-2442-5
30"	CSB 97-3042-5	CAB 97-3042-5

### 48" WIDE x 8' 1" HIGH

Depth	Starter Unit No.	Add On Unit No.
12"	CSB 97-1248-5	CAB 97-1248-5
15"	CSB 97-1548-5	CAB 97-1548-5
18"	CSB 97-1848-5	CAB 97-1848-5
24"	CSB 97-2448-5	CAB 97-2448-5
30"	CSB 97-3048-5	CAB 97-3048-5

### 6 SHELVES 36" WIDE x 8' 1" HIGH

Depth	Starter Unit No.	Add On Unit No.
12"	CSB 97-1236-6	CAB 97-1236-6
15"	CSB 97-1536-6	CAB 97-1536-6
18"	CSB 97-1836-6	CAB 97-1836-6
24"	CSB 97-2436-6	CAB 97-2436-6
30"	CSB 97-3036-6	CAB 97-3036-6

### 42" WIDE x 8' 1" HIGH

Depth	Starter Unit No.	Add On Unit No.
12"	CSB 97-1242-6	CAB 97-1242-6
15"	CSB 97-1542-6	CAB 97-1542-6
18"	CSB 97-1842-6	CAB 97-1842-6
24"	CSB 97-2442-6	CAB 97-2442-6
30"	CSB 97-3042-6	CAB 97-3042-6

### 48" WIDE x 8' 1" HIGH

Depth	Starter Unit No.	Add On Unit No.
12"	CSB 97-1248-6	CAB 97-1248-6
15"	CSB 97-1548-6	CAB 97-1548-6
18"	CSB 97-1848-6	CAB 97-1848-6
24"	CSB 97-2448-6	CAB 97-2448-6
30"	CSB 97-3048-6	CAB 97-3048-6

### 7 SHELVES 36" WIDE x 8' 1" HIGH

Depth	Starter Unit No.	Add On Unit No.
12"	CSB 97-1236-7	CAB 97-1236-7
15"	CSB 97-1536-7	CAB 97-1536-7
18"	CSB 97-1836-7	CAB 97-1836-7
24"	CSB 97-2436-7	CAB 97-2436-7
30"	CSB 97-3036-7	CAB 97-3036-7

### 42" WIDE x 8' 1" HIGH

Depth	Starter Unit No.	Add On Unit No.
12"	CSB 97-1242-7	CAB 97-1242-7
15"	CSB 97-1542-7	CAB 97-1542-7
18"	CSB 97-1842-7	CAB 97-1842-7
24"	CSB 97-2442-7	CAB 97-2442-7
30"	CSB 97-3042-7	CAB 97-3042-7

### 48" WIDE x 8' 1" HIGH

Depth	Starter Unit No.	Add On Unit No.
12"	CSB 97-1248-7	CAB 97-1248-7
15"	CSB 97-1548-7	CAB 97-1548-7
18"	CSB 97-1848-7	CAB 97-1848-7
24"	CSB 97-2448-7	CAB 97-2448-7
30"	CSB 97-3048-7	CAB 97-3048-7

# Tri-Boro Shelving Posts & Foot Plate



## OFFSET ANGLE POST

Made of 14 gauge cold-rolled steel, roll formed into a 1" x 1-7/8" angle. The wide flange is punched on 1-1/2" centers with 7/16" square slots to receive shelf clips and 5/16" diameter holes on 1-1/2" centers for the attachment of side sway braces or solid panels.

Model Number	Size	Wt.
OP37	3'1"	2.0
OP49	4'1"	3.0
OP61	5'1"	4.0
OP73	6'1"	4.8
OP85	7'1"	5.5
OP97	8'1"	6.0
OP109	9'1"	7.0
OP121	10'1"	8.0
OP133	11'1"	8.8
OP145	12'1"	9.5
OP157	13'1"	10.3
OP169	14'1"	11.0
OP181	15'1"	11.8
OP193	16'1"	12.5



## OFFSET ANGLE POSTS - 1" O.C.

Made of 14 gauge cold-rolled steel, roll formed into a 1" x 1-7/8" angle. The wide flange is punched on 1" centers with 7/16" square slots to receive shelf clips and 5/16" diameter holes on 1-1/2" centers for the attachment of side sway braces or solid panels.

Model Number	Size	Wt.
OP39	3'3"	2.0
OP51	4'3"	3.0
OP63	5'3"	4.0
OP75	6'3"	4.8
OP87	7'3"	5.5
OP99	8'3"	6.0
OP111	9'3"	7.0
OP123	10'3"	8.0
OP135	11'3"	8.8
OP147	12'3"	9.5
OP159	13'3"	10.3
OP171	14'3"	11.0
OP183	15'3"	12.1
OP195	16'3"	13.2



## GOVERNMENT POST ROLLED FORMED STEEL

### GOVERNMENT POST

13 gauge hot-rolled steel 1" x 1-3/4" with 1" centers.

Model Number	Size	Wt.
GP75	6'3"	4.9
GP87	7'3"	5.7
GP99	8'3"	6.5



## ROLLED FORMED POST

### ROLLED FORMED POST

A 1-1/4" x 1-1/4" angle made from rolled formed steel with holes punched on 1" centers.

Model Number	Size	Wt.	GA.
RFP39	3'3"	1.8	14
RFP51	4'3"	2.5	14
RFP63	5'3"	2.8	14
RFP75	6'3"	3.6	14
RFP87	7'3"	4.7	13
RFP99	8'3"	5.2	13
RFP111	9'3"	6.1	13
RFP123	10'3"	7.9	12
RFP147	12'3"	9.1	12
RFP171	14'3"	11.9	12



## BOX POST

This clip-type post eliminates items being snagged during loading and unloading. Rectangular holes for clips punched on 1-1/2" centers and 5/16" diameter holes 1-1/2" on center as above.

Made from 14 gauge cold-rolled steel.

Model Number	Size	Wt.
BP37	3'1"	2.2
BP49	4'1"	3.4
BP61	5'1"	4.5
BP73	6'1"	5.4
BP85	7'1"	6.3
BP97	8'1"	7.2
BP109	9'1"	8.1
BP121	10'1"	9.0
BP145	12'1"	12.0

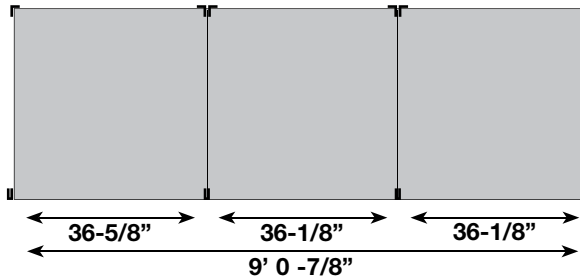

Shelving with box posts at front and offset angle posts at rear.

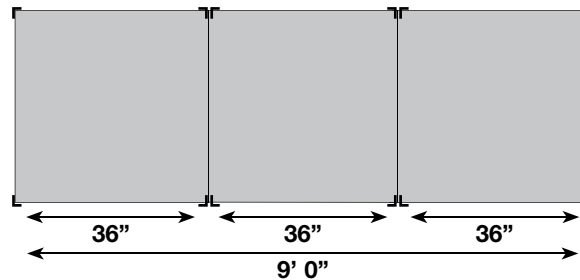

Shelving with offset angle posts front and rear.

When placing units back to back, omit back panel on 1/2 of the units, thus permitting the use of a common back panel. Same applies to open type, omit 1/2 back sways.

## FOOT PLATES



Model Number  
FPOP1 - 1" O.C.

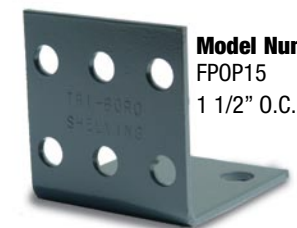

Model Number  
FPOP15  
1 1/2" O.C.



# Tri-Boro Flange & Box Shelves

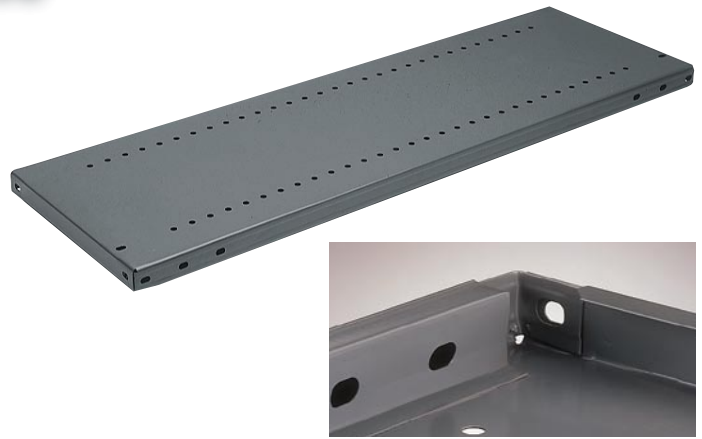

## ADJUSTABLE STEEL FLANGE SHELVES (FOR CLIP-TYPE AND NUT AND BOLT)

All shelves are made of 20 or 18 gauge cold rolled steel. Each side has triple bends for added strength.

NOTE: ADD SUFFIX X FOR 18 GAUGE  
EXAMPLE: S924X = 18 GAUGE 9" x 24"

Model Number	Size	20 GA. Wt.	18 GA. Wt.
S924	9" x 24"	3.8	5.3
S930	9" x 30"	4.8	6.3
S936	9" x 36"	5.0	7.3
S942	9" x 42"	6.9	8.3
S948	9" x 48"	8.9	9.3
S1224	12" x 24"	4.9	6.4
S1230	12" x 30"	5.0	6.7
S1236	12" x 36"	6.5	8.0
S1242	12" x 42"	8.0	10.3
S1248	12" x 48"	9.0	11.6
S1524	15" x 24"	5.9	7.5
S1530	15" x 30"	6.1	9.0
S1536	15" x 36"	7.1	10.5
S1542	15" x 42"	8.2	12.0
S1548	15" x 48"	9.5	13.5
S1824	18" x 24"	6.9	8.7
S1830	18" x 30"	7.0	10.4
S1836	18" x 36"	8.2	12.1
S1842	18" x 42"	9.5	13.8
S1848	18" x 48"	10.7	15.5
S2124	21" x 24"	8.7	10.0
S2130	21" x 30"	8.9	11.3
S2136	21" x 36"	10.5	14.6
S2142	21" x 42"	12.1	16.9
S2148	21" x 48"	13.7	19.2
S2424	24" x 24"	9.0	11.0
S2430	24" x 30"	9.3	13.3
S2436	24" x 36"	11.0	15.6
S2442	24" x 42"	11.9	17.9
S2448	24" x 48"	13.9	20.2
S3030	30" x 30"	13.0	16.6
S3036	30" x 36"	13.5	18.8
S3042	30" x 42"	14.0	21.6
S3048	30" x 48"	17.5	24.4
S3636	36" x 36"	16.0	22.1
S3642	36" x 42"	18.4	25.4
S3648	36" x 48"	19.5	28.6

NOTE: OTHER SIZES AVAILABLE CALL TRI-BORO

## BOXER™ (BOX-SHELF) ADJUSTABLE STEEL BOX SHELVES

Shelves are constructed of 18, 20 or 22 gauge steel with full welded box formation in front and back of shelf and have formed channels on both ends. All four corners are lapped and welded for additional strength. The box formation is welded on a 6-inch center minimum to provide integrity to the entire length of the box. All shelves have a box profile height of 1-1/4". All box shelves are designed to accommodate either clip or nut & bolt connection to the upright, and are punched for dividers on 1" centers.

\*\*BOXER™ shelves are compatible with all existing Tri-Boro shelving components.

NOTE: ADD L FOR 22 GAUGE / ADD X FOR 18 GAUGE

Model Number	Size	22 GA. Wt.	20 GA. Wt.	18 GA. Wt.
BX1224	12" x 24"	4.1	4.8	6.3
BX1230	12" x 30"	5.1	5.8	7.1
BX1236	12" x 36"	6.0	7.2	9.1
BX1242	12" x 42"	6.9	8.4	10.4
BX1248	12" x 48"	7.8	9.5	11.8
BX1524	15" x 24"	4.7	5.6	7.2
BX1530	15" x 30"	5.8	6.8	8.9
BX1536	15" x 36"	7.0	8.4	10.5
BX1542	15" x 42"	8.0	9.7	12.2
BX1548	15" x 48"	9.1	11.0	13.8
BX1824	18" x 24"	5.9	6.3	8.3
BX1830	18" x 30"	6.6	7.7	10.2
BX1836	18" x 36"	8.0	9.6	12.1
BX1842	18" x 42"	9.2	11.1	13.9
BX1848	18" x 48"	10.4	12.6	15.8
BX2124	21" x 24"	6.1	7.1	9.4
BX2130	21" x 30"	7.4	8.7	11.0
BX2136	21" x 36"	9.0	10.8	13.0
BX2142	21" x 42"	10.1	11.8	15.0
BX2148	21" x 48"	11.4	13.4	17.0
BX2424	24" x 24"	6.7	7.9	10.0
BX2430	24" x 30"	8.2	9.7	12.0
BX2436	24" x 36"	10.0	12.0	15.1
BX2442	24" x 42"	11.5	13.8	17.4
BX2448	24" x 48"	13.0	15.7	19.7
BX3030	30" x 30"	9.9	11.6	15.0
BX3036	30" x 36"	12.0	14.4	18.1
BX3042	30" x 42"	13.7	16.6	20.9
BX3048	30" x 48"	15.6	18.8	23.6
BX3636	36" x 36"	13.9	16.8	22.1
BX3642	36" x 42"	16.0	19.3	24.3
BX3648	36" x 48"	18.2	22.0	27.5

NOTE: OTHER SIZES AVAILABLE CALL TRI-BORO

# Tri-Boro Side, Back Panels & Sway Braces

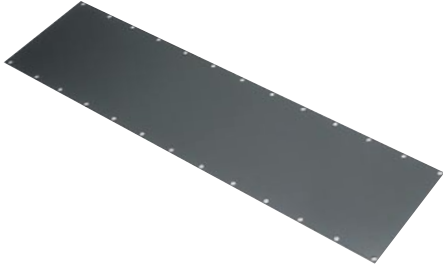

## OFFSET SIDES (Clip-Type Shelving) SIDE PANEL - 24 GA.

Made of cold-rolled steel. Punched along edges with 3/8" dia. holes on 3" vertical centers for attaching to front and rear post.

Model Number	Shelf Depth	Dimensions	Wt.
OS637	9"	6" x 37"	1.5
OS643	9"	6" x 43"	1.8
OS649	9"	6" x 49"	2.0
OS937	12"	9" x 37"	2.4
OS943	12"	9" x 43"	2.7
OS949	12"	9" x 49"	2.7
OS1237	15"	12" x 37"	3.1
OS1243	15"	12" x 43"	3.1
OS1249	15"	12" x 49"	4.1
OS1537	18"	15" x 37"	3.9
OS1543	18"	15" x 43"	4.5
OS1549	18"	15" x 49"	5.1
OS1837	21"	18" x 37"	4.6
OS1843	21"	18" x 43"	5.4
OS1849	21"	18" x 49"	6.1
OS2137	24"	21" x 37"	5.4
OS2143	24"	21" x 43"	6.2
OS2149	24"	21" x 49"	7.1
OS2737	30"	27" x 37"	7.0
OS2743	30"	27" x 43"	8.1
OS2749	30"	27" x 49"	9.2
OS3337	36"	33" x 37"	8.5
OS3343	36"	33" x 43"	9.9
OS3349	36"	33" x 49"	11.2



## OFFSET BACKS (Clip-Type Shelving) BACK PANEL - 24 GA.

Made of cold-rolled steel. Punched along edges with 3/8" dia. holes on 1-1/2" vertical centers of attaching to front and rear post.

Model Number	Shelf Width	Dimensions	Wt.
OB2437	24"	24" x 37"	6.1
OB2443	24"	24" x 43"	7.1
OB2449	24"	24" x 49"	8.1
OB3037	30"	30" x 37"	7.7
OB3043	30"	30" x 43"	9.0
OB3049	30"	30" x 49"	10.2
OB3637	36"	36" x 37"	9.2
OB3643	36"	36" x 43"	10.7
OB3649	36"	36" x 49"	12.2
OB4237	42"	42" x 37"	10.7
OB4243	42"	42" x 43"	12.5
OB4249	42"	42" x 49"	14.2
OB4837	48"	48" x 37"	12.3
OB4843	48"	48" x 43"	14.3
OB4849	48"	48" x 49"	16.3

## CLIP-TYPE SHELVING BACK AND SIDE REQUIREMENTS

To make the following heights of units follow the chart below to determine number and dimensions of components.

Shelving Height	# of Backs or Sides
5' 1"	= 2 Pieces 37"
6' 1"	= 2 Pieces 37"
7' 1"	= 2 Pieces 43"
8' 1"	= 2 Pieces 49"
9' 1"	= 3 Pieces 37"
10' 1"	= 3 Pieces 43"
11' 1"	= 3 Pieces 49"
12' 1"	= 3 Pieces 49"
14' 1"	= 4 Pieces 43"
16' 1"	= 4 Pieces 49"

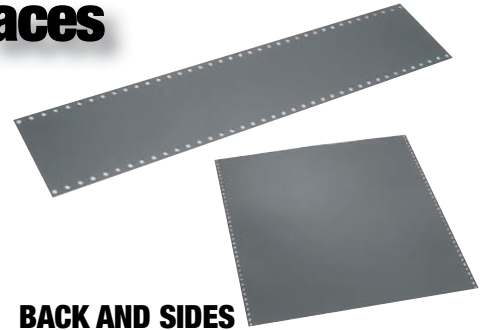

## BACK AND SIDES (Nut and Bolt Type)

Made of cold-rolled steel. Pierced along edges with 3/8" dia. holes on 1" centers for attaching to front and rear post.

**Backs over 4' 3" consist of overlapping pieces.**

Model Number	Size	Wt.
BS939	9" x 3' 3"	2.5
BS945	9" x 45"	2.9
BS951	9" x 4' 3"	3.3
BS1239	12" x 3' 3"	3.0
BS1245	12" x 45"	4.0
BS1251	12" x 4' 3"	5.0
BS1539	15" x 3' 3"	3.5
BS1545	15" x 45"	3.5
BS1551	15" x 4' 3"	5.2
BS1839	18" x 3' 3"	4.5
BS1845	18" x 45"	5.0
BS1851	18" x 4' 3"	6.0
BS2139	21" x 3' 3"	5.7
BS2145	21" x 45"	6.5
BS2151	21" x 4' 3"	7.4
BS2439	24" x 3' 3"	6.0
BS2445	24" x 45"	7.0
BS2451	24" x 4' 3"	8.0
BS3039	30" x 3' 3"	7.5
BS3045	30" x 45"	8.0
BS3051	30" x 4' 3"	9.5
BS3639	36" x 3' 3"	9.0
BS3645	36" x 45"	11.0
BS3651	36" x 4' 3"	12.0
BS4239	42" x 3' 3"	10.5
BS4245	42" x 45"	13.5
BS4251	42" x 4' 3"	15.0
BS4839	48" x 3' 3"	12.0
BS4845	48" x 45"	15.0
BS4851	48" x 4' 3"	16.0

Special sizes available

Special bending for tables and counters available

## NUT & BOLT SHELVING BACK AND SIDE REQUIREMENTS

To make the following heights of units follow the chart below to determine number and dimensions of components.

Shelving Height	# of Backs or Sides	Shelving Height	# of Backs or Sides
5' 3"	= 2 Pieces 3' 3"	10' 3"	= 3 Pieces 45"
6' 3"	= 2 Pieces 3' 3"	11' 3"	= 3 Pieces 4' 3"
7' 3"	= 2 Pieces 45"	12' 3"	= 3 Pieces 4' 3"
8' 3"	= 2 Pieces 4' 3"	14' 3"	= 4 Pieces 45"
9' 3"	= 3 Pieces 3' 3"		



## SWAY BRACES

Made of 1" wide hot-rolled strip with safety edges. Ends are radiused and pierced for attaching to front and rear post.

Model Number	Shelf Size	Wt.
SB18	12"-18"	1.0
SB36	24"-36"	2.0
SB48	42"-48"	3.2

# Tri-Boro Shelving Braces, Shelf Boxes, Shelf Box Dividers, Label Holders, Angle Sways & Splices



## LABEL HOLDERS

Made of cold-rolled steel. Punched on ends for attaching to front edge of shelves. The top and bottom edges are folded over to accommodate labels approximately 1" high.

Model Number	Size	Wt.
LH24	24"	.2
LH30	30"	.3
LH36	36"	.4
LH42	43"	.5
LH48	48"	.6

NOTE: Welded Label Holders Available for flange shelves only.

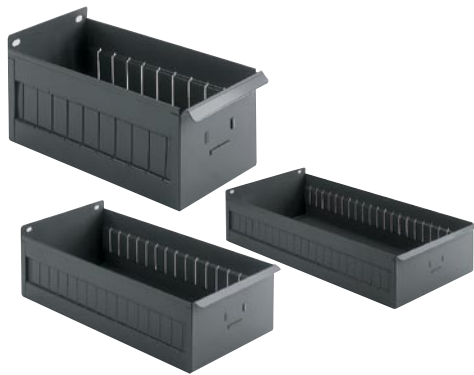

## SHELF BOXES

Front and rear panels are made of 20 gauge steel to help prevent unsightly dings. Body of box is made of 22 gauge steel. Front panel has built-in handle and 2" label holder. All boxes are 4-5/8" high. Dividers are not included but may be added as an option.

Model Number	Size W x H x D	Wt.
SB5410	5-1/2" x 4-5/8" x 10-7/8"	2.16
SB8410	8-1/4" x 4-5/8" x 10-7/8"	2.68
SB11410	11" x 4-5/8" x 10-7/8"	3.28
SB5416	5-1/2" x 4-5/8" x 16-7/8"	3.02
SB8416	8-1/4" x 4-5/8" x 16-7/8"	3.75
SB11416	11" x 4-5/8" x 16-7/8"	4.59
SB5422	5-1/2" x 4-5/8" x 22-7/8"	3.89
SB8422	8-1/4" x 4-5/8" x 22-7/8"	4.82
SB11422	11" x 4-5/8" x 22-7/8"	5.9

## ANGLE SWAYS (For Nut & Bolt Shelving)

A 5" x 5" L-shaped bracket that is made of 13 gauge steel with holes punched 2" on center. Gives 5 points of fastening between shelf and upright to prevent lateral movement when sway bracing is not used.

Model Number	Size	Wt.
AN55	5" x 5"	.02



## OFFSET ANGLE SWAYS

A 5" x 5" L-shaped bracket made of 13 gauge steel with one leg punched on 2" centers and the other punched 1-1/2" on center. Gives 5 points of fastening between shelf and upright to prevent lateral movement when sway bracing is not used.

Model Number	Size	Wt.
OAS55	5" x 5"	.2



## SPLICE (For Rolled Formed Post)

Made of hot-rolled 13 gauge steel. Punched 2" on center for the joining of two roll form posts. Dimensions of splice are 1" x 1" x 7".

Model Number	Wt.
SP 117	.32



## OFFSET SPLICE

Made from cold-rolled 13 gauge steel. Punched on 1-1/2" and 1" on centers from either end for the joining of two offset posts. Dimensions of splice are 3/4" x 1" x 5".

Model Number	Wt.
OSP115	.18
OSP1	.18



## SHELF BOX DIVIDERS

Made of 22 gauge steel. Front face has a pre-punched label holder.

Model Number	Size	Wt.
SBD5	5"	.0
SBD8	8"	.5
SBD11	11"	1.0

## REINFORCEMENTS

A 1" x 1" angle made of 12 gauge steel used to reinforce front and /or back of shelf.

Model Number	Size	Wt.
RB18	18"	.7
RB21	21"	1.0
RB24	24"	1.4
RB30	30"	1.7
RB36	36"	2.0
RB42	42"	2.4
RB48	48"	2.7



# Tri-Boro Shelving Bin Fronts, Bin Dividers & Sliding Dividers



## SLIDING DIVIDERS

Made of cold-rolled steel. Top corners are rounded for safety. Bottom is flanged for attachment to shelf, without hardware, allowing for horizontal mobility.

Model Number	Size H x D	Wt.
SD412	4" x 12"	1.2
SD415	4" x 15"	1.5
SD418	4" x 18"	1.7
SD424	4" x 24"	2.2
SD612	6" x 12"	1.7
SD615	6" x 15"	1.8
SD618	6" x 18"	1.9
SD624	6" x 24"	2.5
SD812	8" x 12"	2.0
SD815	8" x 15"	2.05
SD818	8" x 18"	2.1
SD824	8" x 24"	2.8



## BIN DIVIDERS

Made of cold rolled steel. Front edge is formed into a hem. Top and bottom are flanged and punched for attachment to shelves. Back edge is hemmed to provide rigidity. Dividers are installed with snap-in spring-type clips.

Model Number	Size H x D	Wt.
BD612	6" x 12"	.8
BD615	6" x 15"	1.1
BD618	6" x 18"	1.3
BD624	6" x 24"	1.6
BD812	8" x 12"	1.0
BD815	8" x 15"	1.6
BD818	8" x 18"	1.9
BD824	8" x 24"	2.5
BD912	9" x 12"	.9
BD915	9" x 15"	1.1
BD918	9" x 18"	1.3
BD924	9" x 24"	1.8
BD1012	10" x 12"	1.0
BD1015	10" x 15"	1.6
BD1018	10" x 18"	1.9
BD1024	10" x 24"	2.5
BD1212	12" x 12"	1.3
BD1215	12" x 15"	2.0
BD1218	12" x 18"	2.5
BD1224	12" x 24"	2.9
BD1412	14" x 12"	1.7
BD1415	14" x 15"	2.1
BD1418	14" x 18"	2.5
BD1424	14" x 24"	2.9
BD1512	15" x 12"	1.3
BD1515	15" x 15"	1.7
BD1518	15" x 18"	2.0
BD1524	15" x 24"	2.7
BD1612	16" x 12"	1.9
BD1615	16" x 15"	2.2
BD1618	16" x 18"	2.8
BD1624	16" x 24"	3.8
BD1812	18" x 12"	1.6
BD1815	18" x 15"	2.0
BD1818	18" x 18"	2.4
BD1824	18" x 24"	3.3



## CLIPS FOR BIN DIVIDERS

Model Number	Wt.
CBDIV	8 oz. per 100



## OFFSET BIN FRONTS (Clip-Type Shelving)

Model Number	Size H x W	Wt.
OBF124	1-1/2" x 24"	.6
OBF130	1-1/2" x 30"	.8
OBF136	1-1/2" x 36"	.9
OBF142	1-1/2" x 42"	1.1
OBF148	1-1/2" x 48"	1.9
OBF324	3" x 24"	.9
OBF330	3" x 30"	1.2
OBF336	3" x 36"	1.4
OBF342	3" x 42"	1.7
OBF348	3" x 48"	1.9
OBF624	6" x 24"	1.1
OBF630	6" x 30"	1.4
OBF636	6" x 36"	1.6
OBF642	6" x 42"	1.9
OBF648	6" x 48"	2.2



## BIN FRONTS (Nut and Bolt Shelving)

Made of cold rolled steel. Top edge is formed into a hem. Bottom is flanged to rest on shelf and pierced to provide means of attaching to post.

Model Number	Size H x W	Wt.
BF224	2" x 24"	.9
BF230	2" x 30"	1.2
BF236	2" x 36"	1.4
BF242	2" x 42"	1.6
BF248	2" x 48"	1.8
BF424	4" x 24"	1.6
BF430	4" x 30"	2.0
BF436	4" x 36"	2.5
BF442	4" x 42"	2.8
BF448	4" x 48"	3.2
BF624	6" x 24"	2.3
BF630	6" x 30"	2.8
BF636	6" x 36"	4.0
BF642	6" x 42"	4.4
BF648	6" x 48"	5.1



## OFFSET BIN FRONTS BOX POST (Clip-Type Shelving)

Model Number	Size H x W	Wt.
OBBP324	3" x 24"	.9
OBBF330	3" x 30"	1.2
OBBF336	3" x 36"	1.4
OBBF342	3" x 42"	1.6
OBBF348	3" x 48"	1.9

# Tri-Boro Shelving Clips, Bases, Braces & Hardware



## OFFSET BASES (Clip Shelving)

Made of cold-rolled steel. Channel formed to fit between shelf and floor. Pierced for bolting to holes in front flange of post. Offset bases 3" and higher are punched 1-1/2" on center.

Model Number	Size	Wt.
OBS124	1-1/2" x 24"	.6
OBS130	1-1/2" x 30"	.8
OBS136	1-1/2" x 36"	.9
OBS142	1-1/2" x 42"	1.1
OBS148	1-1/2" x 48"	1.2
OBS324	3" x 24"	.9
OBS330	3" x 30"	1.2
OBS336	3" x 36"	1.2
OBS342	3" x 42"	1.7
OBS348	3" x 48"	1.9



## OFFSET BASES FOR BOX POST (Clip-Type Shelving)

Model Number	Size	Wt.
OBB324	3" x 24"	.9
OBB330	3" x 30"	1.2
OBB336	3" x 36"	1.4
OBB342	3" x 42"	1.7
OBB348	3" x 48"	1.9



## AISLE BRACES (Nut & Bolt Shelving)

Made of 13 gauge channel formed steel with one additional return flange on top for added strength. End tabs are flanged at 90° angles with holes punched on 2" centers.

Model Number	Size	Wt.
AB30	30"	4.6
AB36	36"	5.4
AB42	42"	6.3
AB48	48"	7.1



## BASES (Nut & Bolt Shelving)

Made of cold-rolled steel. Channel formed to fit between shelf and floor. Pierced for bolting to holes in front flange of post. Bases 4" and higher are punched 2" on center.

Model Number	Size	Wt.
BAS212	2" x 12"	.5
BAS215	2" x 15"	.5
BAS218	2" x 18"	.5
BAS224	2" x 24"	.9
BAS230	2" x 30"	1.2
BAS236	2" x 36"	1.4
BAS242	2" x 42"	1.6
BAS248	2" x 48"	1.8
BAS412	4" x 12"	.8
BAS415	4" x 15"	.8
BAS418	4" x 18"	.8
BAS424	4" x 24"	1.6
BAS430	4" x 30"	2.0
BAS436	4" x 36"	2.5
BAS442	4" x 42"	2.8
BAS448	4" x 48"	3.2
BAS612	6" x 12"	1.1
BAS615	6" x 15"	1.1
BAS618	6" x 18"	1.1
BAS624	6" x 24"	2.3
BAS630	6" x 30"	2.8
BAS636	6" x 36"	4.0
BAS642	6" x 42"	4.4
BAS648	6" x 48"	5.1



## OFFSET AISLE BRACES (Clip-Type Shelving)

Made of 13 gauge channel formed steel with one additional return flange on top for added strength. End tabs are flanged at 90° angles with holes punched on 1-1/2" centers.

Model Number	Size	Wt.
OAB30	30"	4.6
OAB36	36"	5.4
OAB42	42"	6.3
OAB48	48"	7.1



## ROUNDHEAD BOLTS WITH SQUARE NUTS

Model Number	Size	Quantity	Wt.
RB63	1/4" x 5/8"	100	2
*RB100	1/4" x 1"	100	2.5
**RB125	1/4" x 1-1/4"	100	3

\* For back to back units.

\*\*Use with angle sways/box shelves



## ROUNDHEAD BOLTS WITH HEX NUTS

Model Number	Size	Quantity	Wt.
HB63	1/4" x 5/8"	100	2



1-1/2" O.C.

## CLIPS FOR OFFSET/BOX POSTS

Model Number	Wt.
COP15	1 oz.



1" O.C.

## CLIPS FOR OFFSET/BOX POSTS

Model Number	Wt.
COP1	1 oz.

# Tri-Boro Shelving Parts Identification & Quick Page Reference

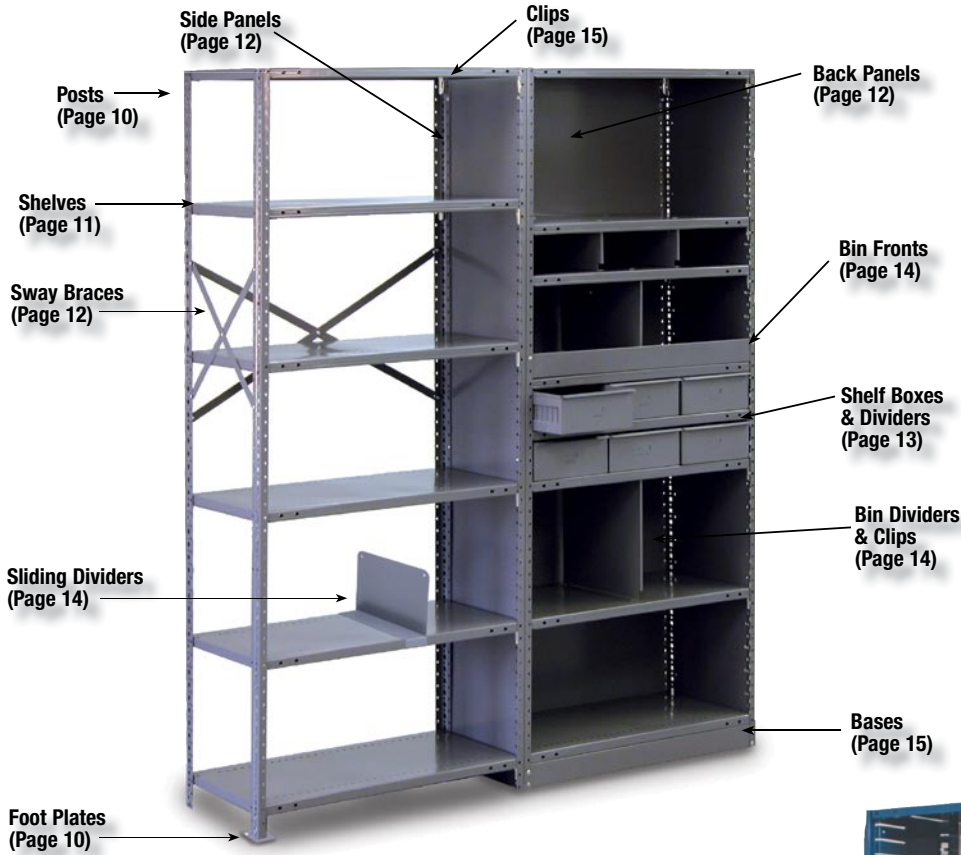

- Additional Parts (Not Shown)**
- Splices, Shelf Reinforcements (Page 13)
  - Angle Sways, Label Holders (Page 13)
  - Aisle Braces (Page 15)

## AUTOMOTIVE SHELVING

Automotive Unit and Accessories	Weight	Part No.
Basic Unit: 12"D x 36"W x 84"H (10 Shelf)	105.0	A361284
<b>Components:</b>		
Extra Slide-In Shelf: 12"D x 36"W	5.5	AS3612
Upright: 12"D x 84"H	15.3	AU1284
Back: 36"W x 84"H	18.0	AB3684
Base: 36"W x 3"H	1.4	AB36
<b>Accessories:</b>		
3" Sliding Parts Divider: 12"D x 3"H	1.2	ASD312
Shelf Box: 10-7/8"D x 5-1/2"W x 4-5/8"H	2.2	ASB5410
Shelf Box Divider: 5"W x 4-3/8"H	0.3	ASBD5

- Unit Color: Blue**
- Back & Accessories Color: Pearl White**



**Automotive Unit with Accessories**