

A photograph showing a long row of blue metal drums stacked on wooden pallets in a warehouse. The drums are arranged in a perspective that recedes into the distance. The lighting is bright, and the background shows the structure of the warehouse.

Drum Handling Solutions

New Item Inside

Page 23

Fork Lift Attachments

Skid Steer Attachments

Portable Lifts

Drum Positioners

Drum Dumpers

Drum Trucks

Drum Dollies



Valley Craft Industries, Inc. designs, develops and manufactures Professional Grade material handling and storage solutions, including a broad array of proprietary and custom products.

Valley Craft was established in 1953 when Carl Weinmann introduced the first hand truck with a brake. Over the last six decades, Valley Craft has grown to become a world class manufacturer known for its expertise in producing rugged and versatile hand trucks, carts, trailers, portable lifts, hydraulic drum handling devices, and storage equipment.

At Valley Craft, we take pride in our heritage of building high quality American-Made products to handle and store materials more safely, more securely, and more efficiently.

On the shores of beautiful Lake Pepin, in Lake City, Minnesota, Valley Craft is staffed by a committed and loyal team of employees - fully a third of our associates have been with the company for more than 25 years. We think, feel, and act like a family and, like a family, we share core values:

- **Respect** - for our customers, our suppliers, our community, and each other.
- **Integrity** - personal and professional integrity in everything we do.
- **Openness** - bad news gets worse with age - we surface problems quickly and get help.
- **Enthusiasm** - we care about what we're doing - it's more fun and we do better work.
- **Commitment** - to continuous improvement in every single thing that we do.

A family company since its inception more than 60 years ago, Valley Craft is currently led by its third private owner - Minnesota businessman Dennis Campbell, who acquired substantially all of the assets of Valley Craft Inc. from Liberty Diversified International in 2012.



Table of Contents

Fork Lift Attachments

Hydraulic.....	4
Skid Steer Attachment	6
Mechanical	7

Portable Lifts

Power Drive	8
Manual Drive.....	12
Portable Lifts & Positioners.....	15
Drum Dollies	19

Drum Dumpers

Low-Level	20
High-Level	21

Hand Trucks & Accessories

Drum Trucks	22
-------------------	----

Lift Truck Attachments - Hydraulic

Valley Craft's lift truck attachments make handling of most* steel, plastic and fiber drums safe, effective and extremely easy. *Note: Only self-powered models work on LP powered forklifts.*



Clamp, Rotate & Tilt

Self-Powered Hydraulic Ultra-Grip™ III is the latest innovation in fork-mounted drum handling! The Ultra-Grip III, an industry exclusive to Valley Craft, provides three fully hydraulic proportionally controlled functions that are activated by an ergonomic hand-held pendant. A single set of fully hydraulic jaws automatically adjust to most drum diameters (18" - 28"). Rotating function offers full 360° rotation for inverting and pouring to both the right and left. Dumping function allows the operator to pour forward 120°. Features infinitely variable speed for optimum control of your load, system pressure gauge and battery discharge indicator with hour meter and clock. Equipped with built-in, 12-volt, battery-operated Power-Pak and self contained hydraulics. Includes corded control box - wireless remote option available. *Note: Batteries & Charger are included.*

Overall Dimensions: 34"W x 69"L x 19"H

Model	Description	Load Capacity	Distance Between Fork Tubes	Fork Tube Size (Usable)	Jaw Size	Product Weight
F89815A5	Ultra-Grip III	2,000 lbs	19 3/8"	2½ x 6½ x 37½"	9" x 15"	891 lbs
F89814A4	Wireless Remote	-	-	-	-	1 lb

*Caution should be used when clamping thin walled drums, open topped drums & smooth sided drums.



Clamp & Rotate

Self-Powered Hydra Grip An industry exclusive to Valley Craft, the self-powered clamp & rotate provides two fully hydraulic functions that are activated by an ergonomic hand-held pendant. A single jaw automatically adjusts to most drum diameters (18" - 28"). Rotating function offers full 360° rotation for inverting and pouring to both the right and left. Features system pressure gauge and battery discharge indicator with hour meter and clock. Equipped with built-in, 12-volt, battery-operated Power-Pack and self contained hydraulics. Includes corded control box. *Note: Batteries & Charger are included.*

Overall Dimensions: 34"W x 66"L x 19"H

Model	Description	Load Capacity	Distance Between Fork Tubes	Fork Tube Size (Usable)	Jaw Size	Product Weight
F89703	Self Powered Hydra Grip	2,000 lbs	19 3/8"	2½ x 6½ x 37½"	9 x 15"	798 lbs



Clamp & Rotate

Lift Truck Powered Hydra Grip Provides two fully hydraulic functions that are activated by an ergonomic hand-held pendant. A single set of fully hydraulic jaws automatically adjust to most drum diameters (18" - 28"). Rotating function offers full 360° rotation for inverting and pouring to both the right and left. Unit requires lift truck equipped with auxiliary valve control and hydraulic quick couplers for operation.

*Note: The clamp/unclamp feature is accomplished via a rope pull activation of the selector valve.

Overall Dimensions: 34"W x 68"L x 17"H

Model	Description	Load Capacity	Distance Between Fork Tubes	Fork Tube Size (Usable)	Jaw Size	Product Weight
F89702	Lift Truck Powered Hydra Grip	2,000 lbs	19 3/8"	2½ x 6½ x 37½"	9 x 15"	834 lbs

Lift Truck Attachments - Hydraulic

Self-Powered Hydraulic Versa-Grip™ II is Valley Craft's answer to drum placement and pouring. This unit features hydraulic gripping and 120° forward dumping capabilities for moving and pouring most steel and fiber drums (18"-28"). Equipped with built-in, 12-volt, battery-operated Power-Pak and self-contained hydraulics. Features system pressure and battery discharge gauges. Includes corded control box. *Note: Batteries & Charger are included.*



Overall Dimensions: 33"W x 67"L x 18"H

Model	Description	Load Capacity	Distance Between Fork Tubes	Fork Tube Size (Usable)	Jaw Size	Product Weight
F89701	Self Powered Versa-Grip II	2,000 lbs	19 3/8"	2½ x 6½ x 37½"	9 x 15"	736 lbs

Lift Truck-Powered Hydraulic Versa-Grip™ II features gripping and 120° forward dumping capabilities for moving and pouring steel and fiber drums (18"-28" diameter). Unit requires lift truck be equipped with auxiliary valve control and hydraulic quick couplers for operation.



*Note: The clamp/unclamp feature is accomplished via a rope pull activation of the selector valve.

Overall Dimensions: 33"W x 67"L x 19"H

Model	Description	Load Capacity	Distance Between Fork Tubes	Fork Tube Size (Usable)	Jaw Size	Product Weight
F89700	Lift Truck Powered Hydraulic Versa-Grip II	2,000 lbs	19 3/8"	2½ x 6½ x 37½"	9 x 15"	381 lbs

Self-Powered Hydraulic Maxi-Grip™ II is a single-function grip designed to handle most plastic, steel & fiber containers (18"-28" diameter) and to increase efficiency of basic moving, stacking and palletizing actions. This unit has no dumping functions, but is optimal for fast and effective warehousing drum inventories. Equipped with built-in, 12-volt, battery-operated Power-Pak and self-contained hydraulics. Features system pressure and battery discharge gauges. Includes corded control box. *Note: Batteries & Charger are included.*

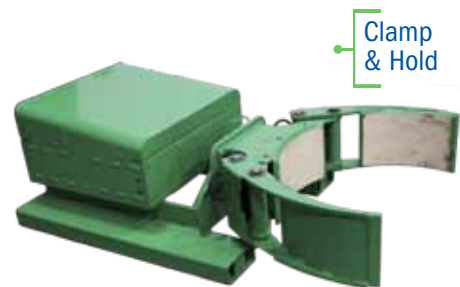

Overall Dimensions: 34"W x 60"L x 19"H

Model	Description	Load Capacity	Distance Between Fork Tubes	Fork Tube Size (Usable)	Jaw Size	Product Weight
F89705	Self Powered Hydraulic Maxi-Grip II	2,000 lbs	19 3/8"	2½ x 6½ x 37½"	9 x 15"	525 lbs

Lift Truck-Powered Hydraulic Maxi-Grip™ II is a single-function grip designed to handle most plastic, steel & fiber containers (18"-28" diameter) and to increase efficiency of basic moving, stacking and palletizing actions. This unit has no dumping functions, but is optimal for fast and effective warehousing drum inventories. Unit is fork-mounted and requires that the lift truck be equipped with auxiliary valve control and hydraulic quick couplers for operation.



Overall Dimensions: 34"W x 60"L x 19"H

Model	Description	Load Capacity	Distance Between Fork Tubes	Fork Tube Size (Usable)	Jaw Size	Product Weight
F89704	Lift Truck Powered Maxi-Grip II	2,000 lbs	19 3/8"	2½ x 6½ x 37½"	9 x 15"	205 lbs

Skid Steer Attachments - Hydraulic



Skid Steer Drum Handler allows operator to handle drums at reclamation areas, construction landfills and any other location where drums and loaders are necessary. The drum handler hydraulically clamps and dumps most drums (18"-28" diameter). Attachment allows for continuous 360° rotation in either direction. Constant hydraulic pressure secures the load, making the unit excellent for salvage operations. Includes rubber-lined jaws, hoses, and standard ½" quick couplers.

***Note: The clamp/unclamp feature is accomplished by activating the selector valve (via a rope pull) on top of the frame. When the rope is not being pulled, the same hydraulic lever will activate the rotating function.*

Model	Description	Load Capacity	Overall L x W	Container Diameter	Jaw Size	Product Weight
F89698	Skid Steer Drum Handler	2,000 lbs	45 x 52"	18 - 28"	9 x 15"	625 lbs



Lift Truck Attachments - Mechanical

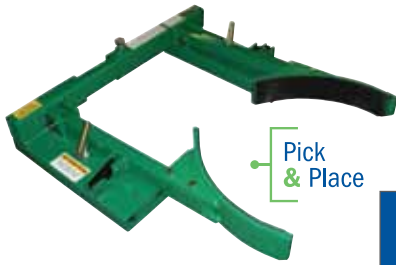

Pick & Place

Gravity-Actuated Mechanical Auto-Grip™ and **Auto-Grip™ DH** are most efficient on consistently sized loads. Auto-Grip™ jaws are spring-and-cam actuated and equipped with jaws that grip with cam pressure that is proportional to drum weight. Standard jaws adjust to fit 30-, 55- or 85-gallon steel or over-pack drums, or any cylindrical object 18"-28" in diameter. Auto Grip DH jaws grip under the top lip and adjust manually to grasp most plastic drums 22"-24" in diameter.

Overall Dimensions: 33"W x 34"L x 7"H

Model	Description	Load Capacity	Distance Between Forks	Fork Tube Size (Usable)	Jaw Size	Product Weight
F86145B0	Auto Grip	1,500 lbs	13 - 25"	1½ x 5½ x 16¾"	3 x 15"	103 lbs
F86165A5	Auto Grip dh	1,000 lbs	17 - 21"	1½ x 5½ x 16¾"	3 x 15"	103 lbs



Pick & Place

Economy Auto Grip is a gravity-actuated mechanical unit that handles consistently sized loads more efficiently than most hydraulic models. This unit is equipped with jaws that grip with cam pressure proportional to drum weight. Cam-actuated jaws automatically grip when engaging drum and release when placing it on the floor.

Overall Dimensions: 24"W x 36"L x 7"H

Model	Description	Load Capacity	Distance Between Forks	Useable Fork Tube Size	Fits Drum Cap. Gal.	For Drum Type	Product Weight
F89743	Economy Auto Grip	1,500 lbs	8"	5 ⅝" W x 1 ⅝" H	30 or 55 gal	Steel	95 lbs

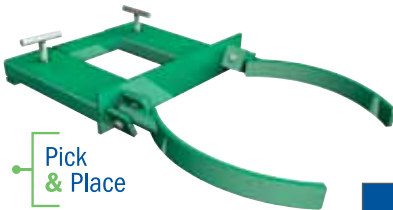

Pick & Place

Drum Snatcher™ is economical and easy to use. Automatically grasps, then moves, stacks and palletizes standard 55-gallon steel-ringed drums 23"-24" in diameter, by utilizing unique knuckle-gripping system and natural pressure of the loaded drum. Designed for customers with limited drum handling needs. Fork-mounted.

Overall Dimensions: 22"W x 36"L x 6"H

Model	Description	Load Capacity	Distance Between Forks	Fork Tube Size (Usable)	Product Weight
F87398A2	Drum Snatcher	800 lbs	8"	1½ x 5½ x 16¾"	56 lbs



Pick & Place

Fork Lift Beak Attachment This attachment is equipped with powerful beak-style jaws that automatically grip when engaging drum and release when lowering it. This product can manage most open or closed top drums having a chime or locking rings strong enough to support the weight of its own contents. Slides onto forks and secures via turn-down t-bolts. Handles most rimmed drums 24" in height or higher.

Overall Dimensions: 24"W x 19"L x 38"H

Model	Description	Load Capacity	Drum Type	Product Weight
F85370A0	Fork Lift Beak Attachment	1,000 lbs	Steel	125 lbs



Pick & Place

Fork Lift Strap Attachment Straps conform to container to give maximum contact. Ratchet devices allow operator to apply exact tension force needed and reduces container damage. Allows user to pick up most any cylindrical object that is smooth-sided.

Overall Dimensions: 24"W x 19"L x 38"H

Model	Description	Load Capacity	Container Diameter	Product Weight
F80147A7	Drum Strap Attachment	800 lbs	14-24"	80 lbs

Portable Lifts - Power Drive

Telescopic Power Drive Roto-Grip™ II Drum Handler

Telescopic Power Drive Roto-Grip™ II Drum Handler lifts, rotates, dumps and palletizes most steel, fiber, and plastic drums and cylinders (18"-28" in diameter) with hydraulic clamping jaws. This counter-weighted model is designed to butt directly up against pallets and containment skids. 12" power drive wheels plus full-function hydraulic lift allows operators to effortlessly move drums up to 1,000 lbs. This drum handler can easily maneuver grades up to 5-degrees and has a turning radius of 71 inches. Hydraulic clamping jaws allow for 360-degree rotation. The telescoping mast allows for easy access in and out of standard doorways, and also provides better operator viewing while transporting loads. Maximum lift height from center of jaws to floor is 84 inches. Curtis TM-1 Tiller Head is equipped with an emergency reverse switch, electronic throttle, rocker switches, horn, keyed on/off switch, and gas spring to automatically return head to upright position when not in use. Features variable drive speed (2.5 mph factory set max), 24-volt DC system and battery indicator gauge. Includes two 12-volt deep-cycle batteries and 12V AC charger.

Model No.	Description	Dimensions H x W x D	Max Lift Travel	Turning Radius	Product Weight (lbs)
F89529	Telescopic Power Drive Roto-Grip™ II	54-90" x 34" x 79"	71"	71"	1,619



Curtis TM-1 Tiller Head

- Load Capacity: 1,000 lbs
- Lift Speed: 17 FPM
- Rotate Speed: 6 FPM
- Mast Height: 54" - 90"
- Rotates: 360-degrees
- Maximum lift height: 84" (from center of jaws to floor)

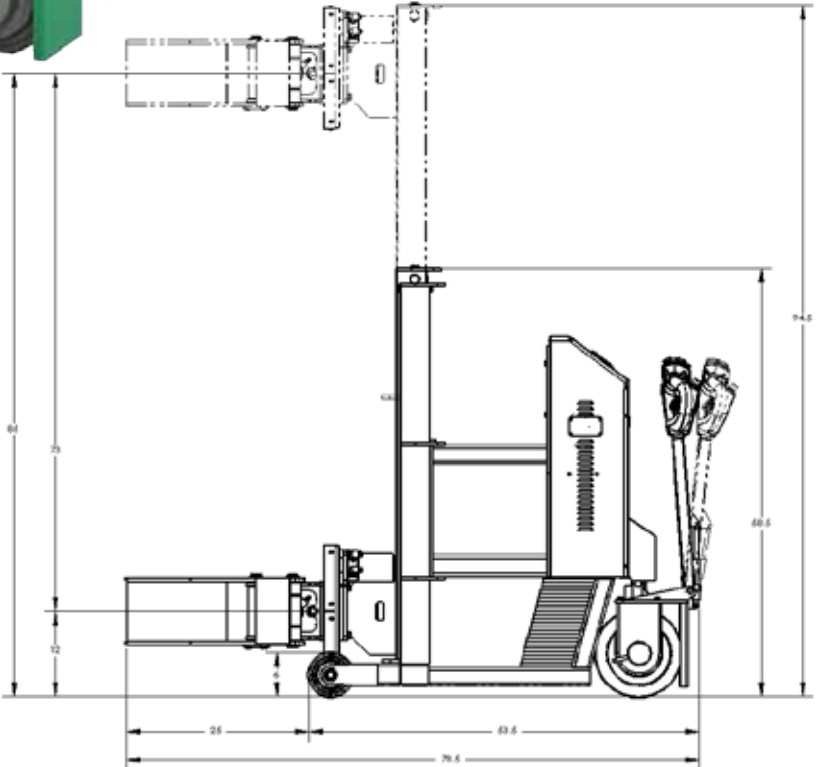

Portable Lifts - Power Drive

Power Drive Roto-Grip™ II Drum Handler

Power Drive Roto-Grip™ II was designed to make transporting, lifting and dumping safer and easier than ever before, combining all these functions into one piece of equipment. These drum handling units can provide substantial cost savings by eliminating the need for fork lifts. Handles most steel, plastic, and fiber drums and cylinders 18"-28" in diameter. Hydraulic clamping jaws allow for 360-degree rotation. 12" power drive wheels plus full-function hydraulic lift and pour means any operator can effortlessly move drums up to 1,000-lbs, while reducing injury rates from heavy handling. The Power Drive Roto-Grip™ II units feature fully adjustable and programmable controls with 1-2.5 mph (2.5 mph factory set max) speed controls, and can easily handle grades up to 5°. Also features a 24-volt DC system, battery indicator gauge, and a keyed On/Off switch. Curtis TM-1 Tiller head equipped with emergency reverse switch, electronic throttle, rocker switches, horn, and gas spring to automatically return head to upright position when not in use. Includes two batteries and 12V AC charger.

Model	Description	Max Lift Travel	Rotate Speed	Lift Speed	Turning Radius	Overall Height	Overall Width	Overall Length	Leg Length	Distance Between Legs	Product Weight
F80144A7	78" Straddle	58"	6 RPM	17 FPM	48"	78"	32"	52"	23"	25"	700 lbs
F80143A6	90" Straddle	71"	6 RPM	17 FPM	48"	90"	32"	52"	23"	25"	750 lbs
F80146A9	78" CW	58"	6 RPM	17 FPM	71"	78"	32"	79"	8"	25"	1,150 lbs
F80145A8	90" CW	71"	6 RPM	17 FPM	71"	90"	32"	79"	8"	25"	1,200 lbs



Straddle Power Drive Roto-Grip™ II

Load Capacity: 1,000 lbs

Maximum lift height for 78" Models: 71" (from center of jaws to floor)

Maximum lift height for 90" Models: 84" (from center of jaws to floor)

• Clamp & Rotate



Counter-Weighted Power Drive Roto-Grip™ II

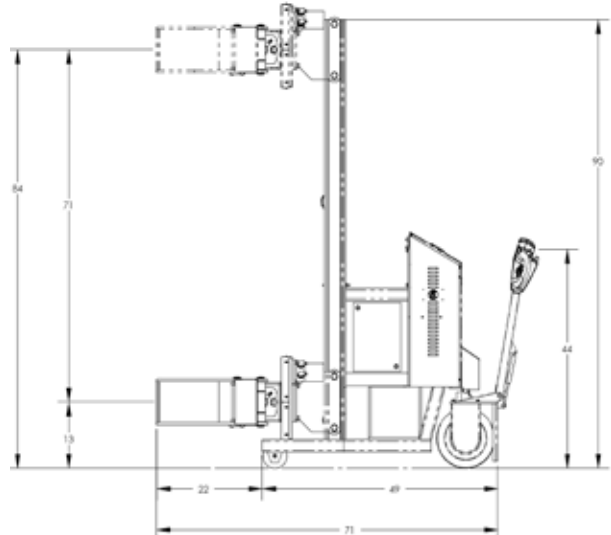
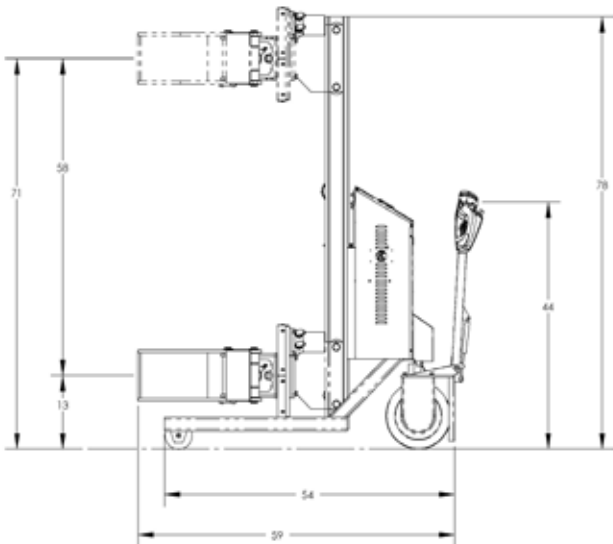

Made with pride in the U.S.A.

Portable Lifts - Power Drive

Power Drive Roto-Lift® Drum Handler

Power Drive Roto-Lift® drum handlers lift, rotate, and dump most steel, fiber, and plastic drums and cylinders (14" -24" in diameter) with ratchet straps. Transporting, lifting, and dumping drums and containers is safer and easier than ever before with the power drive Roto-Lift. 12" power drive wheels plus full-function hydraulic lift and pour means any operator can effortlessly move drums up to 1,000-lbs. A powered drum handler can provide substantial cost savings by eliminating the need for fork lifts. These units feature fully adjustable and programmable controls with 1-2.5 mph speed controls (2.5 mph factory set max) and can easily handle grades up to 5-degrees. Features a 24-volt DC system, battery indicator gauge, and a keyed On/Off switch. Curtis TM-1 Tiller head equipped with emergency reverse switch, electronic throttle, rocker switches, horn, and gas spring to automatically return head to upright position when not in use. Includes two batteries and 12V AC charger.

Model	Description	Max Lift Travel	Rotate Speed	Lift Speed	Turning Radius	Overall Height	Overall Width	Overall Length	Leg Length	Distance Between Legs	Product Weight
F89838A2	78" Straddle	58"	6 RMP	17 FPM	48"	78"	30"	52"	23"	25"	750 lbs
F89837A1	90" Straddle	71"	6 RPM	17 FPM	48"	90"	32"	52"	23"	25"	800 lbs
F89832A5	78" CW	58"	6 RPM	17 FPM	71"	78"	32"	79"	8"	25"	1,400 lbs
F89831A4	90" CW	71"	6 RPM	17 FPM	71"	90"	32"	79"	8"	25"	1,450 lbs



Counter-Weighted Power Drive Roto-Lift®

Load Capacity: 1,000 lbs

Rotates: 360-degrees

Maximum lift height for 78" models: 71"
(from center of straps to floor)

Maximum lift height for 90" models: 84"
(from center of straps to floor)



Curtis TM-1 Tiller Head



Straddle Power Drive Roto-Lift®

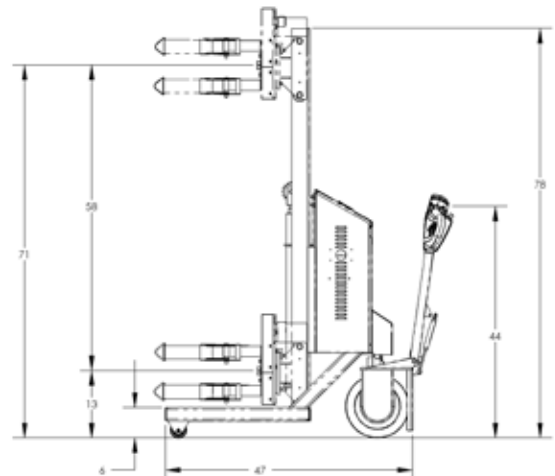
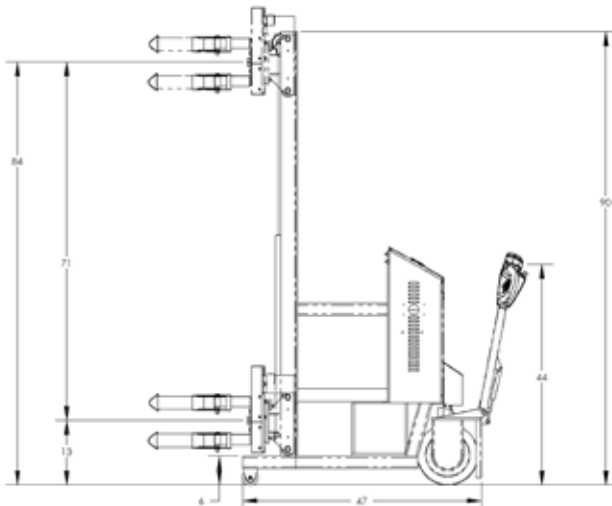

Portable Lifts - Power Drive

Power Drive Versa-Lift™ Handler

Power Drive Versa-Lift™ Drum Handler is a multi-purpose positioner that rolls easily on (2) 3" rigid and (1) 12" swivel poly wheels. Efficiently performs duties and is extremely versatile. 78" and 90" models available, choice of Straddle or Counter-Weighted styles. Optional floor lock available. Unit does not come with an attachment - choose from options (purchased separately) shown below: Drum Grip, Drum Claw, Drum Rotator, Pallet Forks, Drum Forks, Drum Tilter, and Steel Platform. Includes two batteries and 120V AC charger.

Model No.	Description	Dimensions H x W x D	Distance between legs	Max Lift Travel	Lift Speed	Turning Radius	Product Weight (lbs)
F80134A7	Power Drive Versa-Lift™ 78" Straddle	78" x 30" x 48"	25"	58"	17 FPM	48"	700
F80133A6	Power Drive Versa-Lift™ 90" Straddle	90" x 30" x 48"	25"	71"	17 FPM	48"	750
F80136A9	Power Drive Versa-Lift™ 78" C/W	78" x 32" x 48"	25"	58"	17 FPM	71"	1,150
F80135A8	Power Drive Versa-Lift™ 90" C/W	90" x 32" x 48"	25"	71"	17 FPM	71"	1,200



Versa-Lift™ Attachments

Model No.	Description	Load Capacity 12" from Backplate	Drum Diameter	Product Weight (lbs)
F86146A9	Drum Grip	800 lbs	18-23"	108
F88560A2	Drum Claw	800 lbs	18-28"	56
F88562A0	Drum Rotator	800 lbs	14-24"	122
F89406A8	Pallet Forks, 22"	800 lbs	-	43
F89408A6	Drum Stacking Forks	800 lbs	-	87
F89409A5	Drum Tilter	800 lbs	14-24"	66
F89418A4	Steel Platform**	800 lbs	-	24



Drum Rotator rotates 360° and handles fully-loaded drums up to 800 lbs. Includes nylon belts, ratchet tighteners and rubber-coated arms.



Drum Tilter is ideal for occasional one-sided drum pouring. Rotates 120°. Hand crank-operated tilter includes ratchets with nylon straps.



Steel Platform rests on Model #9406 to convert unit into a platform lift for work positioning and heavy items. Measures 24" x 24".



Drum Grip is spring- and cam-actuated to automatically grip as pressure against drum forces jaws down. Adjusts to fit steel drum 18"-23".



Drum Claw is a beak-style grab that grasps the rim of virtually any kind of drum. Attaches without the use of straps.



Pallet Forks move, elevate and stack pallets up to 24" deep. Useful as compact fork truck in congested areas and narrow aisles.



Drum Forks are 24" long and adapted to handle horizontally stacked drums for a fast, efficient way to lift drums in and out of stacking racks.

Portable Lifts - Manual Drive

Manually-Propelled Roto-Grip™ Drum Handler

Manually Propelled Roto-Grip™ Drum Handlers lift and rotate most steel drums and cylinders (18"-24" in diameter) with electric clamping jaws. Choose from 78" or 90" models, straddle or counter-weighted. All units are manually propelled and feature an electric-over-hydraulic control system. Electric screw jack clamps and releases the rubber-lined jaws while the hydraulic rotator turns drums 360°. Single mast design allows for high visibility. 800-lb. load capacity. Optional floor lock available. Electric-over-hydraulic control system requires 12-volt deep cycle battery (included) and plugs into a standard grounded outlet. Counter-weight model is designed to butt directly up against pallets for effective loading and unloading. Counter-weight models weigh twice as much as straddle-type models and require more effort to move.

Model	Description	Max Lift Travel	Lift Speed	Turning Radius	Overall Width	Overall Length	Leg Length	Distance Between Legs	Product Weight
F88585C3	Roto-Grip™ 78" Straddle	58"	17 FPM	44"	30"	45"	24 ¾"	25 ½"	513 lbs
F88586C2	Roto-Grip™ 90" Straddle	71"	17 FPM	44"	30"	45"	24 ¾"	25 ½"	594 lbs
F88587C1	Roto-Grip™ 78" C/W	58"	17 FPM	65"	30"	62"	4"	NA	1,208 lbs
F88588C0	Roto-Grip™ 90" C/W	71"	17 FPM	65"	30"	62"	4"	NA	1,273 lbs
F89410A2	Floor Lock (Straddle models only)	—	—	—	—	—	—	—	4 lbs
F89413A9	Floor Lock (C/W models only)	—	—	—	—	—	—	—	4 lbs

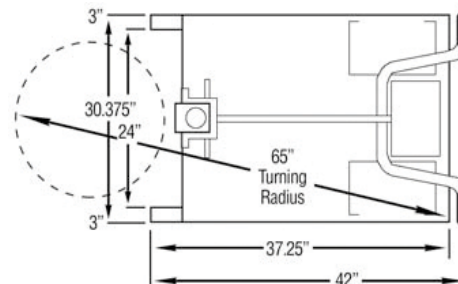
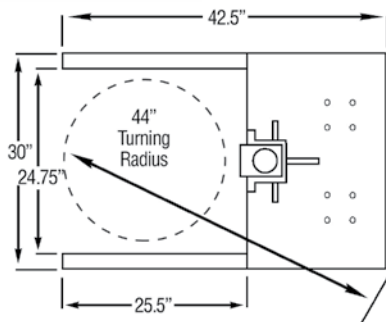
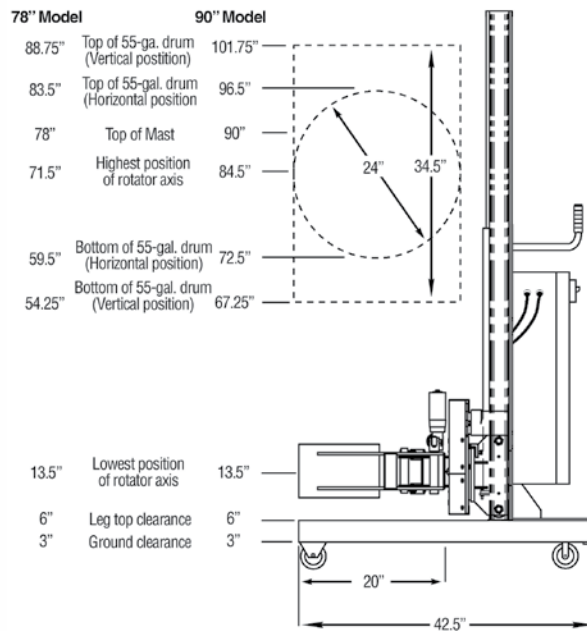

Base for Straddle Roto-Grip™

Base for Counter-Weighted Roto-Grip™

Portable Lifts - Manual Drive

Manually-Propelled Roto-Lift® Drum Handler

Manually Propelled Roto-Lift® Drum Handlers transport, lift, and rotate most steel, plastic, and fiber drums and cylinders 14"-24" in diameter. Rotates full 360°. Available in 78" or 90" models, straddle or counter-weighted, and offer different power sources: manual, battery, air, or 110V AC. Battery-powered models require 12-volt deep cycle battery (included) and plugs into a standard grounded outlet. Air-powered models are ideal for spark-resistant applications and require outside air source. Optional floor lock available. 800-lb. load capacity. Counter-weighted models are designed to butt directly up against pallets to make loading and unloading safe and effective. Counter-weighted models are twice as heavy and require more effort to move.

Model	Description	Max Lift Travel	Lift Speed	Turning Radius	Overall Width	Overall Length	Leg Length	Distance Between Legs	Product Weight
F88565C7	Roto-Lift® 78" Battery Straddle	58"	17 FPM	44"	30"	42 ¾"	24 ¾"	25 ½"	550 lbs
F88569C3	Roto-Lift® 78" Battery C/W	58"	17 FPM	61 ¼"	30"	42 ½"	4"	24"	1,155 lbs
F88566C6	Roto-Lift® 90" Battery Straddle	71"	17 FPM	44"	30"	42 ¾"	24 ¾"	25 ½"	576 lbs
F88570C0	Roto-Lift® 90" Battery C/W	71"	17 FPM	61 ¼"	30"	42 ½"	4"	24"	1,155 lbs
F88563B9	Roto-Lift® 78" Manual Straddle	58"	5 FPM	44"	30"	42 ¾"	24 ¾"	25 ½"	457 lbs
F88580B8	Roto-Lift® 78" Manual C/W	58"	5 FPM	61 ¼"	30"	42 ½"	4"	24"	1,040 lbs
F88564B8	Roto-Lift® 90" Manual Straddle	71"	5 FPM	44"	30"	42 ¾"	24 ¾"	25 ½"	501 lbs
F88581B7	Roto-Lift® 90" Manual C/W	71"	5 FPM	61 ¼"	30"	42 ½"	4"	24"	1,047 lbs
F88589B9	Roto-Lift® 78" Air Straddle	58"	17 FPM	44"	30"	42 ½"	24 ¾"	25 ½"	488 lbs
F88591B5	Roto-Lift® 78" Air C/W	58"	17 FPM	61 ¼"	30"	42 ½"	4"	24"	1,010 lbs
F88590B6	Roto-Lift® 90" Air Straddle	71"	17 FPM	44"	30"	42 ½"	24 ¾"	25 ½"	508 lbs
F88592B4	Roto-Lift® 90" Air C/W	71"	17 FPM	61 ¼"	30"	42 ½"	4"	24"	1,040 lbs
F87786B2	Roto-Lift® 78" A/C Straddle	58"	17 FPM	44"	30"	42 ½"	30"	25 ½"	490 lbs
F87787B1	Roto-Lift® 90" A/C Straddle	71"	17 FPM	44"	30"	42 ½"	30"	25 ½"	510 lbs
F89410A2	Floor Lock Straddle	—	—	—	—	—	—	—	4 lbs
F89413A9	Floor Lock C/W	—	—	—	—	—	—	—	4 lbs



Straddle Manual Drive Roto-Lift®



Counter-Weight Manual Drive Roto-Lift®

Portable Lifts - Manual Drive

Manually-Propelled Versa-Lift™ Handler

Manually Propelled Versa-Lift™ is an efficient multi-purpose positioner with a single-post design to provide high visibility. Available in 78" or 90" models, with several power options: manual foot pump, air motor, 110-volt AC motor, or 12-volt DC motor. Optional floor lock available. Unit does not come with a drum handling attachment - choose from options (purchased separately) shown below: Drum Grip, Drum Claw, Drum Rotator, Pallet Forks, Drum Forks, Drum Tilter, and Steel Platform. 800-lbs load capacity.

Model	Description	Max Lift Travel	Lift Speed	Product Weight
F88567B5	Versa-Lift™ 78" Manual	58"	5 FPM	335 lbs.
F88568B4	Versa-Lift™ 90" Manual	71"	5 FPM	357 lbs.
F87022B6	Versa-Lift™ 78" Air	58"	17 FPM	335 lbs.
F87040B4	Versa-Lift™ 90" Air	71"	17 FPM	380 lbs.
F87785B3	Versa-Lift™ 78" 110-volt AC	58"	17 FPM	376 lbs.
F87803B1	Versa-Lift™ 90" 110-volt AC	71"	17 FPM	392 lbs.
F88553C1	Versa-Lift™ 78" 12-volt DC	58"	17 FPM	467 lbs.
F88561C1	Versa-Lift™ 90" 12-volt DC	71"	17 FPM	489 lbs.



Versa-Lift™ Attachments

Model	Description	Drum Diameter	Load Capacity	Product Weight
F86146A9	Drum Grip	18-23"	800 lbs.	108 lbs.
F88560A2	Drum Claw	18-28"	800 lbs.	56 lbs.
F88562A0	Drum Rotator	14-24"	800 lbs.	122 lbs.
F89406A8	Pallet Forks, 22"	—	800 lbs.	43 lbs.
F89408A6	Drum Forks	—	800 lbs.	87 lbs.
F89409A5	Drum Tilter	14-24"	800 lbs.	66 lbs.
F89418A4	Steel Platform**	—	800 lbs.	24 lbs.
F89410A2	Floor Lock	—	800 lbs.	4 lbs.

**Must be used with F89406A8 Pallet Forks



Drum Grip is spring-and cam-actuated to automatically grip as pressure against drum forces jaws down. Adjusts to fit steel drum 18-23" in diameter.



Pallet Forks move, elevate and stack pallets up to 24" deep. Useful as compact fork truck in congested areas and narrow aisles.



Drum Tilter is ideal for occasional one-sided drum pouring. Rotates 120°. Hand crank-operated tilter includes ratchets with nylon straps.



Drum Claw is a beak-style grab that grasps the rim of virtually any kind of drum. Attaches without the use of straps.



Drum Forks are 24" long and adapted to handle horizontally stacked drums for a fast, efficient way to lift drums in and out of stacking racks.



Steel Platform rests on Model #9406 to convert unit into a platform lift for work positioning and heavy items. Measures 24" x 24".



Drum Rotator rotates 360° and handles fully-loaded drums up to 800 lbs. Includes nylon belts, ratchet tighteners and rubber-coated arms.



Floor Lock fits any model of Versa-Lift™, Roto-Lift™ or Roto-Grip™. Floor Lock Model #9413 available for counterweighted Roto-Lift™.



The Level Lift Forward Dump is the only forward dumping drum handler in the industry with a hand crank dump and no messy chains. Dumpers also incorporate a unique auto-drum leveling feature as drum is raised or lowered. Manual hydraulic, AC Electric, and Battery-Powered units have manual dump control with full 360-degrees forward or reverse rotation, allowing operators to pour drum contents in a precise manner. Easy-to-load bonded rubber cradles handle 800-lb fully loaded or 500-lb half-full drums. Additional features include a heavy duty welded frame, step-down floor locks, and 8" Polyolefin wheels and 4" swivel casters. The maximum lift height is measured from floor to lowest point of a horizontal 55-gallon drum. Optional Drum Adaptor (F89769A9) can quickly convert the standard cradle from a 23" to 18" diameter to handle 30-gallon drums.



Item #F89769A9 - Optional adapter is available to quickly convert the standard cradle from a 23" to 18" diameter to handle 30-gallon drums.



Manual Hydraulic Forward Dump

Model	Description	Load Capacity	Max Lift Height	Frame L x W	Tilt Control	Straddle Legs Inside Width	Straddle Legs Outside Width
F89806A4	Manual Forward Dump	800 lbs	72"	68"x 59"	Manual	30"	41"
F89762	Manual Forward Dump	800 lbs	96"	84" x 59"	Manual	32"	44"

Electric-Powered Forward Dump

Model	Description	Load Capacity	Max Lift Height	Frame L x W	Tilt Control	Straddle Legs Inside Width	Straddle Legs Outside Width
F89748	120V Power Forward Dump	800 lbs	72"	68"x 59"	Manual	30"	41"
F89747	120V Power Forward Dump	800 lbs	96"	84"x 59"	Manual	32"	44"

Battery-Powered Forward Dump - The only forward dump in the industry with a 110-volt on-board battery charger. Also equipped with 12-volt deep-cycle battery.

Model	Description	Load Capacity	Max Lift Height	Frame L x W	Tilt Control	Straddle Legs Inside Width	Straddle Legs Outside Width
F89759	12V Power Forward Dump	800 lbs	72"	68" x 59"	Manual	30"	41"
F89758	12V Power Forward Dump	800 lbs	96"	84" x 59"	Manual	32"	44"

Air-Powered Forward Dump

Model	Description	Load Capacity	Max Lift Height	Frame L x W	Tilt Control	Straddle Legs Inside Width	Straddle Legs Outside Width
F89761	Air Power Forward Dump	800 lbs	72"	68" x 59"	Manual	30"	41"
F89760	Air Power Forward Dump	800 lbs	96"	84" x 59"	Manual	32"	44"

Positioners

Safely and easily unload pallets and containment skids with our Barrel Hawk™ series of portable drum handlers. Each unit designed with a smaller footprint to effectively maneuver through congested work areas.

Model	Description	Container Diameter	Load Capacity	Product Weight
F88575C5	Raptor	30-85 gal.	800 lbs	262 lbs
F88576B4	Harrier	9 - 18" cylinders	800 lbs	265 lbs
F88577B3	Raptor DH	14 - 24" cylinders	800 lbs	288 lbs
F64657A7	Strap Attachment	14 - 24" cylinders	800 lbs	31 lbs



Strap Attachment F64657A7

Barrel Hawk™ Raptor is ergonomically designed to reduce the risk of injury and allow a single operator to safely handle virtually any kind of drum up to 800 lbs. Employs drum claw-type grab to attach to rim of 30-, 55- and 85-gal. over-pack drums. Glides over standard pallets and picks from containment skids with ease. Hand operated hydraulic pump lifts typical 55-gal. drum 20" off floor. Rolls on 6 x 2" phenolic wheels in front, 8" rear swivel caster, and is equipped with a brake for added safety. Single mast design for high visibility. Dimensions: 50"W x 40"L x 67"H. Optional Strap Attachment available, pictured below.



Barrel Hawk™ Raptor F88575C5

Barrel Hawk™ Raptor DH is available as an attachment to the Raptor or as its own unit. The unit is equipped with dual ratchet assemblies and 2" nylon straps. It is designed to handle most steel, plastic and other soft-sided drums. Glides over standard pallets and picks from containment skids with ease. Same ergonomic design as a standard Raptor. Rear swivel caster is equipped with a brake for added safety. Single mast design for high visibility and small footprint for excellent maneuverability. Hand operated hydraulic pump lifts typical 55-gal. drums, up to 800lbs, 20½" off floor.



Barrel Hawk™ Raptor DH F88577B3

30 Gal.

49"	Highest position of jaws
26-1/4"	Lowest height of jaws
21-3/4"	Height to bottom of drum (max.) (Standard steel drum)
9-1/2"	Leg top clearance
7"	Ground clearance
6-1/8"	Lowest position of drum support

55 Gal.

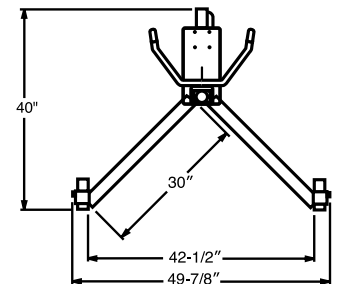
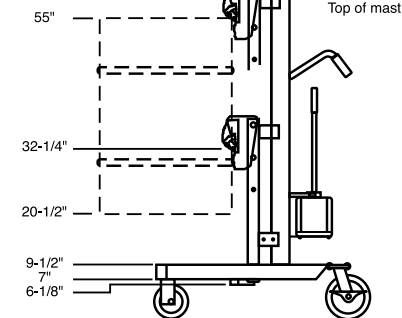

Barrel Hawk™ Harrier quickly and safely secures and transports gas and cryogenic cylinders with ease. The small footprint is ideal for negotiating narrow aisles and doorways. Ergonomically designed to reduce the chance of muscle injury to the operator. Back caster is equipped with a brake for added safety. Unit equipped with adjustable cylinder claw and two ratchet belt tighteners to handle a variety of cylinder types and sizes 9"-18" in diameter. Hydraulic pump raises cylinders 20½" from floor. 800-lb. load capacity. For safety reasons, load should be only 1" from floor during transport.

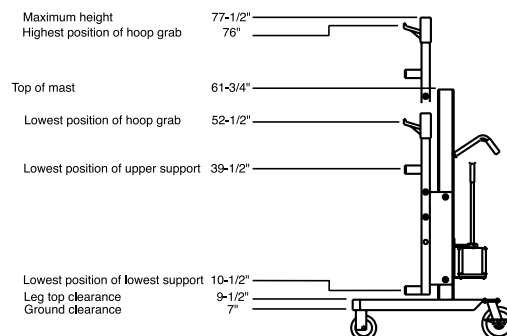

Barrel Hawk™ Harrier F88576B4

The **Falcon Drum Handler/Portable Lift** is an economic, multi-purpose material handler suitable for a variety of pick-and-place applications. It is manually-propelled with a single mast design that offers high visibility and a 800 lb. capacity. This lightweight unit weighs only 95 lbs and its toolless, quick release back plate allows users to quickly change attachments to perform a variety of tasks. Lifting is performed with a side-wind jack and start positions can be achieved quickly by moving the jacks pin location. Heavy duty steel construction. Does not come with an attachment. Attachments available for separate purchase include: Platform, Hook, Torch, Strap, Harrier, and Beak.

Model	Description	Overall Size (LxWxH)	Load Capacity	Max Lift Travel	Wheels	Weight
F89744	Falcon Base	32.4" x 46" x 54.8"	800 lbs	15"	8" Phenolic 3" Nylon	95 lbs



Falcon Base Unit



Harrier Attachment (F89739) Dual ratchet strap attachment designed specifically for compressed gas and cryogenic tanks. Also works well on a variety of other tall containers (9-18" in diameter).



Oxy-Acetylene Torch Attachment (F89737) Features OSHA compliant fire barrier for 24hr storage without separating tanks. Comes standard with tool box for tips and hose hangers. Safely move tanks without requiring the operator to balance the load.



Platform Attachment (F89735) Attachment is bolt together and can be configured for your specific application. It can be used as an adjustable height bench or flipped over and used as a parts tray.



Strap Attachment (F89738) Dual ratchet strap assemblies allow this attachment to lift a variety of containers up to 24" in diameter.



Beak Attachment (F89740) Gravity actuated beak grips and lifts from the rim of your container. Works well on a variety of containers where the rim is strong enough to support the weight.



Hook Attachment (F89736) Hooks are adjustable to fit a large range of rib topped containers. Gravity keeps the hooks engaged and allows containers to be moved from one location to another.

Attachments

Model	Description	Dimensions	Drum Type	Drum/Cylinder Diameter	Weight
F89735	Platform Attachment Q-Release	32.2"W x 24"D x 14.5"H	—	—	55 lbs
F89736	Hook Attachment Q-Release	34"W x 21"D x 27"H	Steel, Plastic	18"- 24"	62 lbs
F89737	Torch Attachment Q-Release	31.5"W x 17.5"D x 59.75"H	—	—	145 lbs
F89738	Strap Attachment Q-Release	24.5"W x 12.5"D x 25"H	Steel, Fiber, Plastic	14"- 24"	45 lbs
F89739	Harrier Attachment Q-Release	16.5"W x 9.5"D x 42.5"H	Cylinder	9"- 18"	44 lbs
F89740	Beak Attachment Q-Release	9"W x 7.5"D x 27"H	Steel	18"- 24"	25 lbs

Portable Lifts

The **Barrel Hawk™ II** base unit is a drum handling portable lift that features 18" of lift height and 800-lbs lifting capacity. Equipped with adjustable legs and a hand-operated pallet-jack style hydraulic lift, the Barrel Hawk™ II is extremely versatile and maneuverable. The universal quick-release backplate allows the unit to work with various size containers and perform many other pick and place tasks. Telescoping legs can be adjusted for transportation through doorways or narrow aisles as load center permits. This unit does not include any attachments - must be purchased separately. Attachments available include: Platform, Hook, Torch, Strap, Harrier, and Beak.

Model	Description	Overall Size (LxWxH)	Max Lift Travel	Wheels	Capacity lbs	Weight
F89741	Barrel Hawk™ II Base	40" x 50" x 64"	18"	6" Poly on Cast (rear) 6" Rubber (front)	800	230



Barrel Hawk II Base Unit shown with Beak Attachment F89740



Telescoping legs can be adjusted for transportation through doorways or narrow aisles as load center permits.



Harrier Attachment (F89739)
Dual ratchet strap attachment designed specifically for compressed gas and cryogenic tanks. Also works well on a variety of other tall containers (9"-18" in diameter).



Oxy-Acetylene Torch Attachment (F89737)
Features OSHA compliant fire barrier for 24hr storage without separating tanks. Comes standard with tool box for tips and hose hangers. Safely move tanks without requiring the operator to balance the load.



Platform Attachment (F89735) Attachment is bolt together and can be configured for your specific application. It can be used as an adjustable height bench or flipped over and used as a parts tray.



Strap Attachment (F89738)
Dual ratchet strap assemblies allow this attachment to lift a variety of containers up to 24" in diameter.



Beak Attachment (F89740)
Gravity actuated beak grips and lifts from the rim of your container. Works well on a variety of containers where the rim is strong enough to support the weight.



Hook Attachment (F89736)
Hooks are adjustable to fit a large range of rib topped containers. Gravity keeps the hooks engaged and allows containers to quickly be moved from one location to another.

Attachments

Model	Description	Dimensions	Drum Type	Drum/Cylinder Diameter	Weight
F89735	Platform Attachment Q-Release	32.2"W x 24"D x 14.5"H	—	—	55 lbs
F89736	Hook Attachment Q-Release	34"W x 21"D x 27"H	Steel, Plastic	18"- 24"	62 lbs
F89737	Torch Attachment Q-Release	31.5"W x 17.5"D x 59.75"H	—	—	145 lbs
F89738	Strap Attachment Q-Release	24.5"W x 12.5"D x 25"H	Steel, Fiber, Plastic	14"- 24"	45 lbs
F89739	Harrier Attachment Q-Release	16.5"W x 9.5"D x 42.5"H	Cylinder	9"- 18"	44 lbs
F89740	Beak Attachment Q-Release	9"W x 7.5"D x 27"H	Steel	18"- 24"	25 lbs

Drum Dollies

Drip Catching Drum Dolly is specially designed to be used with an absorbent sock for soaking up liquids from dispensing drums. Oversized dolly helps keep drips in the pan and area around the drum clean. Also eases handling of over-pack drums. Handles drums 22"-28" in diameter. 1,000-lbs load capacity.

Absorbent sock included with model 9713 only.



Handles drums 22" to 28" in diameter.

Model	Description	Load Capacity	Product Weight
F89709A2	Dolly without absorbent collar	1000 lbs	30 lbs
F89713A6	Dolly with absorbent collar	1000 lbs	32 lbs

Drum Dumpers

Single-Stage Low-Level Dumpers

Dump heights from 36" to 60" with a 45° maximum dumping angle.

Valley Craft's Low Level Drum Dumpers are available in Stationary or Portable models, 1,000-lb. or 1,500-lb. capacities, with dump heights ranging from 36" to 60" with a 45-degree dumping angle. With user safety our number one priority, Valley Craft's drum dumpers include a NEMA12 power up/gravity down power unit with adjustable flow control to safely lower chute to its down position. The 1/60/110V power unit is equipped with a 1HP motor and a 1GPM pump. Drum dumpers feature an adjustable hold-down bar to accommodate various drum heights up to 43". Constructed of heavy gauge carbon steel with an enamel finish.



Note: For requirements not covered by standard specifications or for custom applications, please call for additional information.

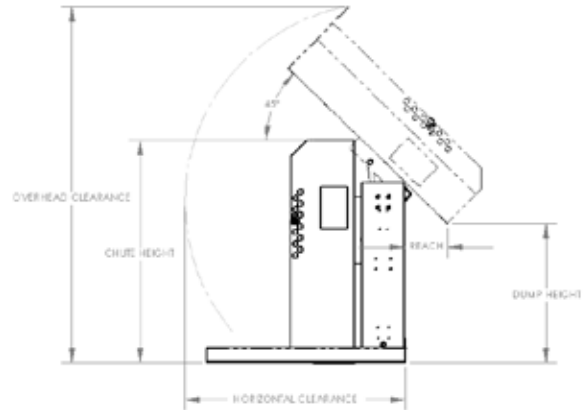
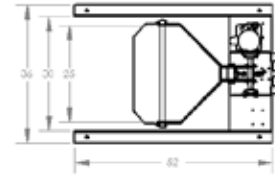

Stationary Models

Model #	Load Capacity	Dump Height	Chute Height	Chute Reach	Frame W x L	Horizontal Clearance	Overhead Clearance	Product Weight
F80169A9	1,000 pounds	36"	60.5"	11"	36 x 52"	62"	95"	363 lbs
F80167A7	1,000 pounds	48"	66.5"	9"	36 x 52"	69"	112"	404 lbs
F80165A5	1,000 pounds	60"	72.5"	7"	36 x 52"	76"	129"	446 lbs
F80163A3	1,500 pounds	36"	58"	11"	36" x 52"	60"	96"	660 lbs
F80161A1	1,500 pounds	48"	65"	9"	36" x 52"	68"	112"	690 lbs
F80159A9	1,500 pounds	60"	72"	7"	36" x 52"	77"	129"	720 lbs

Portable Models

Model	Load Capacity	Dump Height	Chute Height	Chute Reach	Frame W x L	Horizontal Clearance	Overhead Clearance	Product Weight
F80168A8	1,000 pounds	36"	62"	11"	36 x 52"	62"	95"	413 lbs
F80166A6	1,000 pounds	48"	66.5"	9"	36 x 52"	69"	112"	510 lbs
F80164A4	1,000 pounds	60"	72.5"	7"	36 x 52"	76"	129"	496 lbs
F80162A2	1,500 pounds	36"	58"	11"	36" x 52"	60"	96"	510 lbs
F80160A0	1,500 pounds	48"	65"	9"	36" x 52"	68"	112"	530 lbs
F80158A8	1,500 pounds	60"	72"	7"	36" x 52"	77"	129"	563 lbs



Dual-Stage High-Level Dumpers

Dump heights from 72" to 120" with a 45° maximum dumping angle.

High Level Drum Dumpers are available in Stationary or Portable models, with dump heights ranging from 72" to 120" with a 45-degree dumping angle. 1,500-lb load capacity. Chute rises vertically until arms meet pivot rollers, causing chute to rotate. Includes NEMA12 power up/gravity down power unit with adjustable flow control to safely lower chute to its down position. The 1/60/110V power unit is equipped with a 1HP motor and a 1GPM pump. Drum dumpers feature an adjustable hold-down bar to accommodate various drum heights up to 43". Constructed of heavy gauge carbon steel with an enamel finish.

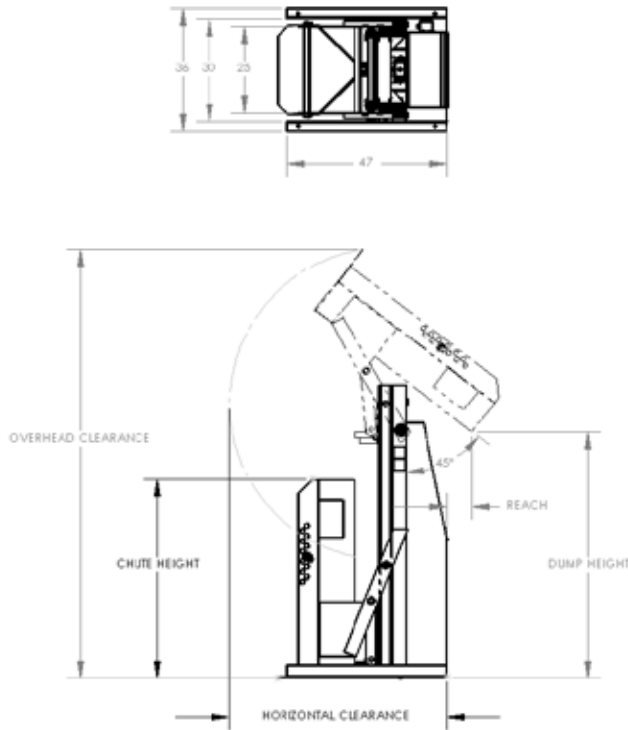

Stationary Models

Model	Load Capacity	Dump Height	Chute Height	Chute Reach	Frame W x L	Horizontal Clearance	Overhead Clearance	Product Weight
F80157A7	1,500 lbs	72"	58"	6"	36" x 47"	66"	130"	1,125 lbs
F80155A5	1,500 lbs	84"	58"	6"	36" x 47"	66"	140"	1,160 lbs
F80153A3	1,500 lbs	96"	58"	6"	36" x 47"	66"	152"	1,200 lbs
F80151A1	1,500 lbs	108"	58"	6"	36" x 47"	66"	164"	1,235 lbs
F80149A9	1,500 lbs	120"	58"	6"	36" x 47"	66"	176"	1,475 lbs

Portable Models

Model	Load Capacity	Dump Height	Chute Height	Chute Reach	Frame W x L	Horizontal Clearance	Overhead Clearance	Product Weight
F80156A6	1,500 lbs	72"	58"	6"	36" x 51"	66"	130"	1,125 lbs
F80154A5	1,500 lbs	84"	58"	6"	36" x 51"	66"	140"	2,260 lbs
F80152A2	1,500 lbs	96"	58"	6"	36" x 51"	66"	152"	2,300 lbs
F80150A0	1,500 lbs	108"	58"	6"	36" x 51"	66"	164"	1,235 lbs
F80148A8	1,500 lbs	120"	58"	6"	36" x 51"	66"	176"	1,275 lbs

Drum Trucks

EZY-Rol™ Automatic Drum Trucks are the answer to safe and effective manual transport and handling of drum inventories. All drum trucks feature Valley Craft's exclusive EZY-Tilt® design and spring-loaded standard chime hook so the operator never has to touch the drum. Choice of steel or spark resistant aluminum frames, 2-wheel or 4-wheel models. Shoes adjust to handle 30- and 55-gal. drums up to 1,000 lbs. Available with optional hand brakes for added safety. Replaceable wheels, shoes and axles available. Four additional chime hooks and three wheel options available.

2-Wheel Steel Frame, Standard Chime

Model	Tires	Product Weight
F81600A9	Pneumatic	67 lbs
F82025A4	Pneumatic with Brakes	78 lbs
F81735A7	Solid Rubber	70 lbs
F82150A1	Solid Rubber with Brakes	78 lbs
F81895A3	Mold-On Rubber	66 lbs



4-Wheel Steel Frame, Standard Chime

Model	Tires	Product Weight
F82375A0	Pneumatic	45 lbs
F83160A7	Pneumatic with Brakes	50 lbs
F82895A1	Solid Rubber	50 lbs
F83450A6	Solid Rubber with Brakes	55 lbs
F82845A2	Mold-On Rubber	55 lbs



2-Wheel Aluminum Frame, Standard Chime

Model	Tires	Product Weight
F81500A0	Pneumatic	45 lbs
F81925A7	Pneumatic with Brakes	50 lbs
F81625A0	Solid Rubber	50 lbs
F82050A2	Solid Rubber with Brakes	55 lbs
F81770A3	Mold-On Rubber	55 lbs

4-Wheel Aluminum Frame, Standard Chime

Model	Tires	Product Weight
F82175A2	Pneumatic	49 lbs
F82960A1	Pneumatic with Brakes	54 lbs
F82425A0	Solid Rubber	48 lbs
F83210A7	Solid Rubber with Brakes	52 lbs
F82645A4	Mold-On Rubber	50 lbs

All drum trucks feature standard chime hook. Special chime hooks available for an additional charge.

NOTE When ordering optional chime hooks, add the following letters to the drum truck model number:

P: Plastic Drum Chime Hook, **L:** Locking Cover Chime Hook, **F:** Fiber Drum Chime Hook, **C:** Cable Hoop Chime Hook



Standard Chime Hook
Automatically engages drum. Comes standard on automatic drum trucks.



Plastic Drum Chime Hook
Hook Drops over bung hole projection on standard drums. May be used on aluminum truck.



Cable Hoop Chime Hook
Hook Cable on standard chime hook wraps around drums without a chime.



Fiber Drum Chime Hook
Reaches an extra inch to hook rim of fiber drums. Also handles standard drums.



Locking Cover Chime Hook
Handles drums with Locking cover. May be used on aluminum truck and handles standard drums.



How to easily use Valley Craft's EZY-Tilt® Drum Trucks:

Our exclusive, automatic, spring-loaded chime hooks are an essential part of Valley Craft's EZY-Tilt® design. Loading and unloading is as easy as 1, 2, 3 and the operator never has to touch the drum.



1. Place shoes securely against base of drum.



2. Tip frame against drum to engage hook.



3. Break over load and rest on all four wheels.

Optional Braking System:

Our unique braking system features a simple hand lever that operates brake bands equally on both load-carrying wheels, providing a safer and more efficient way to move heavy loads. These brakes give the operator complete control on ramps and inclines, and keep the wheels stationary while breaking over loads. Not available with molded-on solid rubber tires.



Tire Options:



Pneumatic Tire
12 x 3½"
Disassembles to replace tire and tube.



Solid Rubber Tire
10 x 2½"
Standard tire on all drum trucks.



Molded-On Tire
10 x 2½"
Brakes not available with this wheel.

Heavy Duty Powered Drum Trucks are designed for safe navigation of heavy loads in tight quarters and on inclines or uneven terrain. Perfect for places where traditional powered machines will not work due to space restriction. Features include a rugged 24V DC differential drive motor, full function forward and reverse travel with reverse audible warning, built-in 18 AH battery with charging/monitor system, and exclusive easy grip hand brake. Shoes adjust to handle 30- and 55-gal. drums up to 800 lbs. Includes our standard spring-loaded drum chime hook - four optional chime hooks available. Speed settings include 1.4MPH (walk) or 0.5MPH (crawl) speeds. 4-Wheel system includes (2) 10" solid rubber drive wheels and (2) 6" follower wheels. High-traction pneumatic wheels also available.

Model	Description	Tires	Dimensions	Load Capacity	Product Weight
F89503	Steel Powered Hand Truck	(2) 10" Solid rubber drive wheels, (2) 6" follower wheels	60"L x 24.5"W x 20"H	800 lbs	150 lbs
F89484	Steel Powered Hand Truck	(2) 12" Pneumatic drive wheels, (2) 8" follower wheels	62"L x 25"W x 20"H	800 lbs	160 lbs



Valley Craft has the equipment to safely and effectively handle your workload and securely store and transport shop, office and facility supplies in all areas of your work environment.

For more ValleyCraft solutions, visit www.valleycraft.com or call (651) 345-3386

Storage Solutions

- High-Capacity Cabinets
- Electronic Locking Cabinets
- Heavy Duty Shelf Cabinets
- Shop Desks
- Modular Mobile Cabinets
- Security Trucks

Material Handling Solutions

- Hand Trucks
- A-Frames
- Platform Trucks
- Security Trucks
- EZ Dump Hopper System
- Waste and Chip Trucks
- Trailers
- Box Dumpers
- Work Tables

2001 South Highway 61, Lake City, MN 55041

Ph: (651) 345-3386 or (800) 328-1480

Fax: (651) 345-3606

valleycraft.com

© All Rights Reserved

Rev071714

