

SOLUTIONS FOR INTRALOGISTICS

EFFICIENT, ERGONOMIC AND SAFE



TENTE

BETTER MOBILITY. BETTER LIFE.



YOUR PARTNER FOR BETTER MOBILITY

Our castors and wheels improve your intralogistics thanks to easy handling, maximum reliability, and above all, the comprehensive approach of our employees. We do not just offer you individual components, but intelligent system solutions. Solutions that ensure more efficient processes. You will find a wide range of castors for industrial applications and products for driverless transport systems. We are also the ideal partner for the automotive sector, because we possess extensive experience in this area, and have access to a strong industry network.

MAXIMUM RELIABILITY

Whether short or long driving distances - our castors and wheels meet the highest requirements. This means that we will provide you with solutions for low-vibration transport and good grip even on wet and slippery floors. Our non-marking products guarantee reduced abrasion and protect flooring.

SOLUTIONS FOR HEALTH PROTECTION

Our wheels with optimised roll resistance take the strain off the user and ensure the application is ergonomically friendly. Our self-aligning castors ensure excellent driving stability with tigger trains while further reducing the strain on the user. Partially elastic foot protection reduces the risk of accidents and can also be used on uneven floors. We also provide you with electric drive systems that enable heavy loads to be moved effortlessly.

On the following pages you can find more information about our intralogistics mobility solutions. Please feel free to contact us for further technical details or a personal consultation.

EFFICIENT TRANSPORT WITH E-DRIVE

The smart solution, our electric drive system, also known as the "E-Drive", allows employees to effortlessly transport a large volume of goods and not only improves productivity, but also enhances staff well-being and reduces operating costs.

Practical system solution

Easy to integrate system solution consisting of drive unit, control module, manual operating unit, battery, charger and mounting set.

High flexibility

The E-Drive system can be individually configured according to the customer's requirements. The system can be easily integrated into existing applications. In stand-by mode, the drive wheel is retracted so that the trolley can be moved manually.

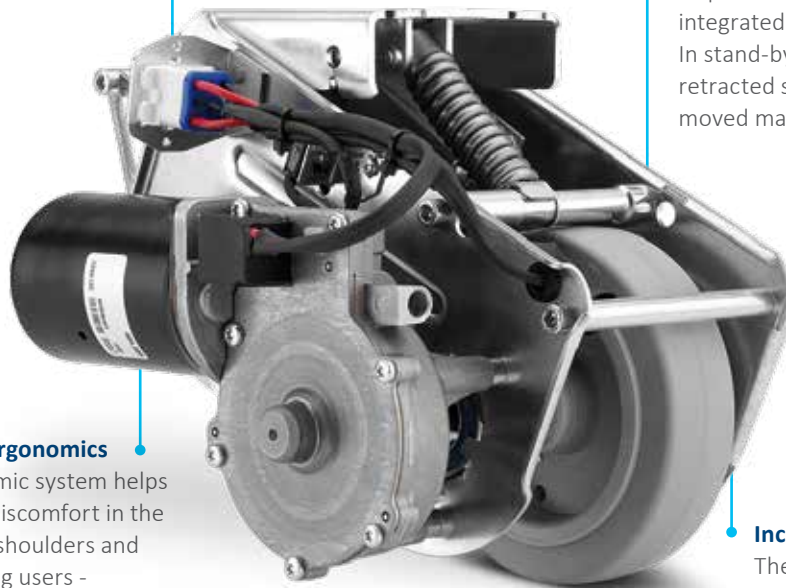

Improved ergonomics

The ergonomic system helps to prevent discomfort in the neck, back, shoulders and hands among users - especially in times of high demographic change. Ergonomic handling and operation means fewer absences due to illness, allowing a quick regain of the initial cost of the E-Drive system.

Increased productivity

The E-Drive makes operating processes more efficient, resulting in cost savings.



"From our point of view as a user, the flexible and easily controllable E-Drive solution provided by TENTE fits very well into our Kaizen approach."

Axel Zühlke, Logistics Director at Esselte Leitz

Read more about the customer reference:
www.tente.com/esselte-leitz

SAVE TIME AND EFFORT WITH CENTRAL LOCKING CASTORS

Using a central operating lever, multiple castors can be locked simultaneously, thereby increasing productivity and reducing the user's workload.



CENTRAL LOCKING POSSIBLE FOR THE FOLLOWING PRODUCT FAMILIES:



Alpha

200 - 400 kg
160 - 200 mm



Delta

540 - 600 kg
160 - 200 mm

SAFE WORKING PROCESSES WITH ALPHA SAFETY

📦 200 - 400 kg 🛠️ 200 - 240 mm ⚙️ 160 - 200 mm

Our Alpha safety with automatic locking system can only be moved if the user keeps the operating handle pressed. When the handle is released, the castors are automatically locked and the working platform is instantly brought to a safe stance.

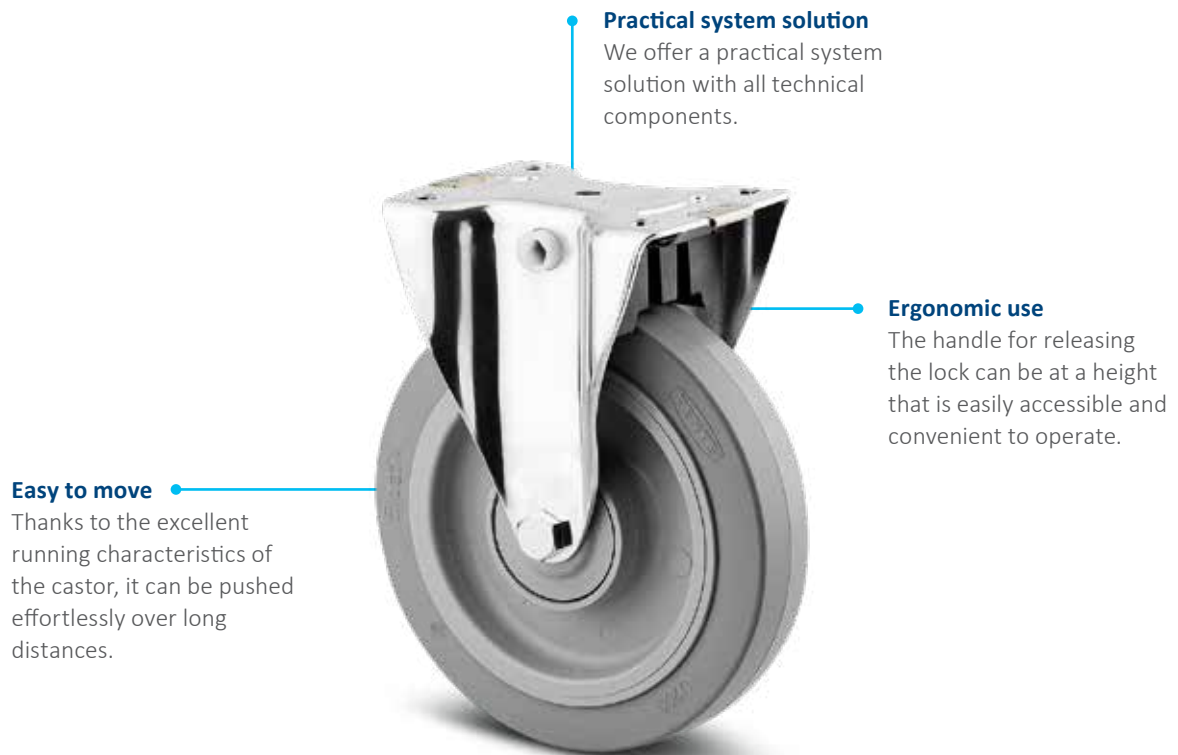

"TENTE Alpha safety is a solution with built-in workplace safety."

Yves Héroumont, Technical Service, SNCB

Read more about the customer reference:
www.tente.com/sncb

OPTIMISED SAFETY WITH FOOT PROTECTION

⊗ 125 - 250 mm*

With the foot protection system from TENTE you avoid accidents at work and ensure the highest level of workplace safety. The flexible rubber guards can also be used on uneven floors, and thus ensure problem-free transport.



Protects employees
The foot protector prevents any contact between the foot and wheel.

Flexible use
Suitable for flat and uneven floors, as well as for driving over ramps and barriers at an inclination of 15°.

Retrofittable
The adapted fork from our Delta, Zeta and Kappa product family allows a fast and uncomplicated retrofit.

Flexible rubber
The flexible rubber guard is shaped in such a way that they are pressed in towards the wheel as soon as the wheel comes into contact with the foot. This prevents the castor from moving over and crushing the foot.

Robust steel
A rigid guard rail made of steel is attached to the side of the wheel. This ensures that the foot is guided safely around the side of the wheel.



Mounted foot protector



"With TENTE's solution we have improved both workplace safety and the protection of our products."

Tobias R ther, Corporate Safety Coordinator of the INTERPANE Group

Read more about the reference:
www.tente.com/interpane

IMPROVED ERGONOMICS WITH LINEA

📏 120 - 150 kg 🔄 125 - 177 mm ⚙️ 100 - 150 mm

Unlike a castor with only one wheel, the TENTE Linea with two wheel action has an extremely low swivel resistance for easy maneuverability with little physical effort. Additionally, the combination of metal and plastic has numerous advantages for the user: The metal components offer high stability, and the plastic components have low vibration properties.



SAFE TRANSPORT WITH KAPPA FLEX

 **360 - 750 kg**  **160 - 200 mm**

With Kappa Flex, your goods are transported safely. The spring-loaded housing construction and additionally integrated springs compensate for uneven floors resulting in a system that is perfectly and flexibly suited for every requirement and load.

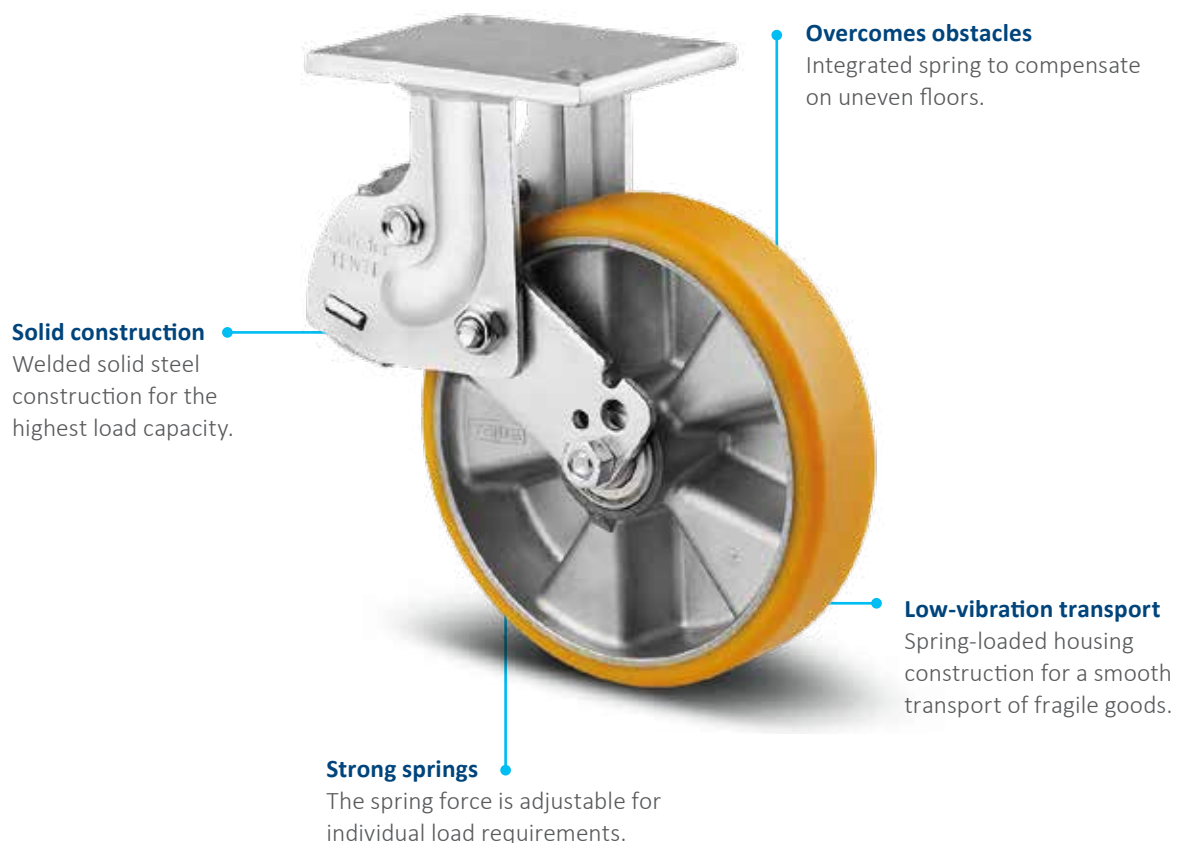

OPTIMISED WORKING PROCESSES WITH SCOUT

📏 150 - 350 kg 📏 202 - 245 mm 📏 160 - 200 mm

Thanks to its compact design, the Scout is the perfect solution for driverless transport trolleys. As the Scout is made from stainless steel, it is washable. We also offer a version which protects users and devices from electrostatic discharge.



UNINTERRUPTED PROCESSES WITH OMIKRON

📏 2.000 - 11.000 kg 🛞 170 - 570 mm 🌀 100 - 500 mm

We offer a wide range of high-load castors. The castor with the highest load capacity is our Omikron quadro castor for the safe transport of heavy loads. Extremely reliable due to solid construction and high-quality polyurethane running surfaces.

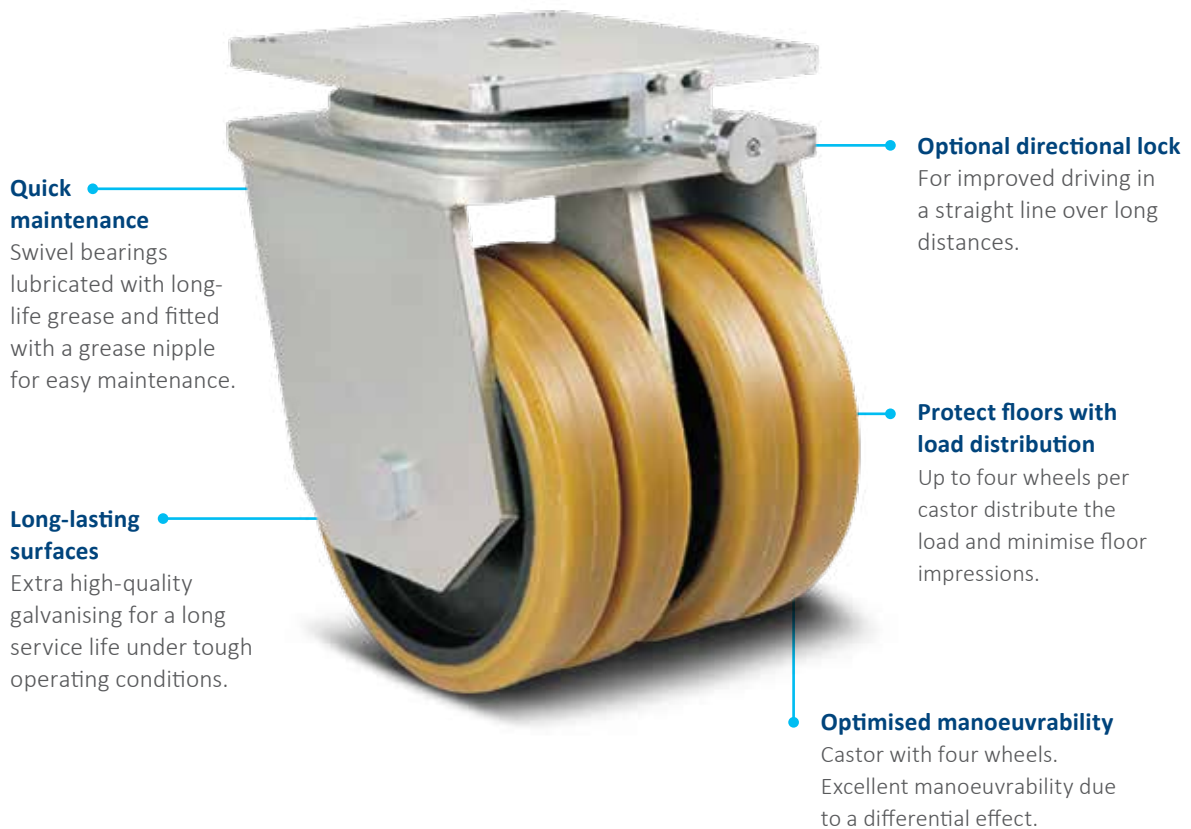

"What convinced us was the durability of the special castors as well as the know-how of our partners at TENTE."

Maarten Van Looveren, General Manager at AVT Europe

Read more about the reference:
www.tente.com/avt-europe

LESS WEAR AND TEAR WITH DURATECH WHEELS

Our robust Duratech wheels are strong and almost indestructible, made of polyamide and duroplastic.



INCREASED PRODUCTIVITY WITH ULTRATECH WHEELS

Outstanding performance due to premium polyurethane. Ideal for applications with heavy loads moving at high speed in tough working conditions.



QUIET WORKING ENVIRONMENT WITH ELASTECH WHEELS

Quiet wheels made of elastic and silicone rubber for the highest running comfort to reduce noise emission.



HIGH LOAD CAPACITY WITH NOVATECH WHEELS

Thanks to cut-resistant and anti-static resistant material, Novatech wheels are the optimal low-maintenance solution for both tough operating conditions and sensitive environments.

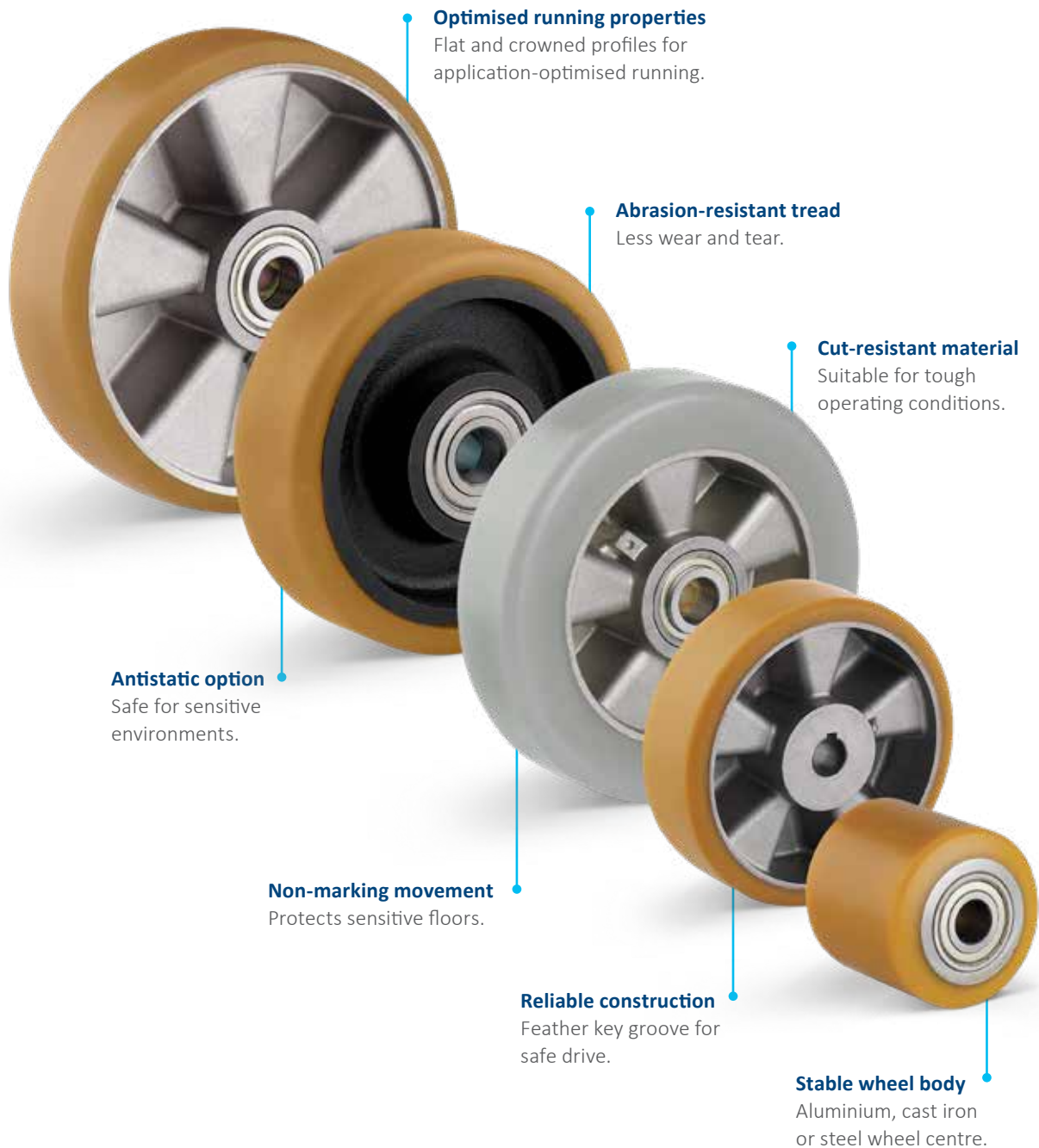

DIVERSITY WITH A SYSTEM

OUR CASTORS

All of our products have their own specific qualities and strengths. Whether it's high design standards, specialist applications or exceptional load capacities – our range can meet your needs and be adapted to fit different models.

From the correct dimensions and technical specifications to the required configuration, our product families are able to offer the ideal solution – whatever you need. Contact us for more information or visit our website: www.tente.com

E-Drive



⌀ 125 mm

Alpha



⊃ 70 - 500 kg
⌀ 80 - 200 mm

Delta



⊃ 300 - 600 kg
⌀ 125 - 200 mm

Delta twin



⊃ 600 - 750 kg
⌀ 125 - 200 mm

Zeta



⊃ 300 - 800 kg
⌀ 125 - 250 mm

Kappa



⊃ 300 - 2.000 kg
⌀ 80 - 300 mm

Kappa flex



⊃ 360 - 750 kg
⌀ 160 - 200 mm

Omikron



⊃ 900 - 11.000 kg
⌀ 100 - 500 mm

Radiata



1.200 - 1.500 kg
80 mm

Scout



150 - 350 kg
160 - 200 mm

Integral



100 - 150 kg
100 - 200 mm

Integral twin



125 - 250 kg
100 - 150 mm

Linea clinic



150 - 200 kg
125 - 150 mm

Aviana care



100 kg
75 mm

Aviana



75 mm

Agila



40 - 100 kg
50 - 150 mm

Agila twin



50 - 100 kg
50 - 75 mm

Stora



60 - 160 kg
75 - 160 mm

Mono



30 - 70 kg
50 - 100 mm

Galea



60 - 100 kg
100 - 125 mm

Levina



60 - 100 kg
75 - 150 mm

Linea



40 - 150 kg
50 - 150 mm

Anika



40 - 50 kg
55 - 75 mm

Lumina



30 - 100 kg
35 - 75 mm

Stylea



40 - 100 kg
35 - 100 mm

Smiles



40 kg
50 mm

Compacta



10 - 55 kg
14 - 50 mm

EXPERTISE THAT INSPIRES

CONTACT US

We are a globally operating company supporting you on five continents. This means on-site support with service on a level playing field – along with in-depth knowledge. Additionally, our solution experts will advise you on the best mobility concept for your needs. Go here to find your nearest TENTE location: www.tente.com/locations

INCREASE YOUR EFFICIENCY

Our intelligent mobility solutions help you save time, effort, energy, and operating expenses. This allows you to improve your operating methods and working conditions, thereby optimising your processes and ensuring higher productivity, profitability and safety. Ask for our solutions catalogue or read about how our customers benefit from our tailor-made solutions on our website: www.tente.com/solutions

SAVE DEVELOPMENT TIME

On our website you will find technical drawings, product data sheets and 2D and 3D CAD files in various formats: www.tente.com/products

GET MORE INFORMATION

In addition to our informative website, you can easily download various catalogues and brochures on mobility solutions, customer references, and much more: www.tente.com/download



ER LIFE.

ET



www.tente.com



PRODUCTIVITY



SAFETY



DESIGN



DURABILITY

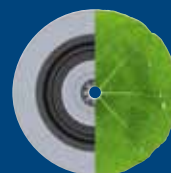

ENVIRONMENT