

Guidelines for Specifying...

# **AUTOMATED ELECTRIFIED MONORAIL SYSTEMS**

---



8720 Red Oak Blvd., Suite 201  
Charlotte, NC 28217-3992  
Telephone: 704-676-1190  
Fax: 704-676-1199  
[www.mhia.org/mma](http://www.mhia.org/mma)

## **TABLE OF CONTENTS**

---

- 1.0 General
  - 2.0 AEM General Specifications
  - 3.0 AEM Track
  - 4.0 Conductor Bars
  - 5.0 System Types
  - 6.0 AEM Vehicles
  - 7.0 AEM Carriers (Load Fixture)
  - 8.0 AEM Horizontal Turns
  - 9.0 AEM Track Switches and Turntables
  - 10.0 AEM Incline
  - 11.0 AEM Anti-Back-Up Device (On Incline Track)
  - 12.0 AEM Anti-Runaway Device (On Incline Track)
  - 13.0 AEM Vertical Drop or Lift Sections
  - 14.0 Maintenance Spurs
  - 15.0 Dead End Spurs
  - 16.0 Considerations for AEM Diagnostics
  - 17.0 Terms and Definitions
-

# **GUIDELINES FOR SPECIFYING AUTOMATED ELECTRIFIED MONORAIL (AEM) SYSTEMS**

## **1.0 GENERAL**

### **1.1 Purpose**

These Guidelines have been developed by the member companies of the Automated Electrified Monorail (AEM) Product Section of the Material Handling Institute, a division of the Material Handling Industry (MHI), which is comprised of leading suppliers of Automated Electrified Monorail systems in North America.

Their purpose is to act as a guide in the selection, design, planning and implementation of Automated Electrified Monorail Systems.

### **1.2 Scope**

These guidelines apply to AEM systems utilizing both single and multiple tracks either suspended type or “inverted” including all curves, switches, transfer devices, trolley, lift/drop section and associated equipment. The Guidelines do not encompass all of the safety precautions and safeguards applicable to monorail systems primarily used for the transportation of personnel.

### **1.3 Disclaimers**

The Guidelines are advisory only. They have been promulgated by the member companies of the Automated Electrified Monorail Product Section of MHI with the sole intent of offering information for the parties engaged in the marketing, buying or use of such systems. Reference to the Guidelines in inquiries by the purchaser is permissible. They are not intended to and do not in any way limit the prerogative of a manufacturer to design or produce Automated Electrified Monorail Systems. Whenever mandatory or other language used in the guidelines seems to impose requirements, these are intended to be advisory only.

#### **1.3.1 Disclaimer of Warranty**

AEM and MHI make no warranties whatsoever in connection with these Guidelines. They specifically disclaim all implied warranties of merchantability or of fitness for particular purpose. No warranties (express, implied, or statutory) are made in connection with these Guidelines.

#### **1.3.2 Disclaimer of Liability**

Users specifically understand and agree that AEM, MHI, their officers, agents and employees should not be liable in tort and in contract-whether based on warranty, negligence, strict liability, or any other theory of liability - for any action or failure to act in respect to the design, erection, installation, manufacture, preparation for sale, characteristics, features, or delivery of anything derived from, or covered by, these Guidelines. By employing or otherwise referring to these Guidelines, it is the user’s intent and understanding to absolve and protect AEM, MHI, their successors, assigns, officers, agents, and employees from any and all tort, contract, or other liability.

## **2.0 AEM GENERAL SPECIFICATIONS**

**2.1** Reference may be made to portions of other specifications within the text of these specifications. Referenced specifications are as follows:

**ANSI** C1 National Electric Code

**AISC** Specification for Design, Fabrication and Erection of Steel for Buildings of the American Institute of Steel Construction.

**NEMA** National Electrical Manufacturers Association Standards

**ANSI/AWS** D1.1 American Welding Society Specification for Structural Welding. (Current Revision).

**OSHA** Applicable Occupational Safety and Health Standards.

**VDI** 3643 Recommended guidelines by the Association of German Engineers for Electrified Monorails (EHB - Electro Hangebahnen).

**2.2** For the purpose of these specifications it is assumed that the AEM vehicles and equipment will operate indoors in normal ambient temperatures (0 to 40C) and normal atmospheric conditions; free from excessive dust, moisture and corrosive fumes. When severe atmospheric conditions, outdoor application and/or heavier duty cycles may apply or occur, special design considerations should be given and fully defined in the requirements.

### **2.3 Design Criteria**

**2.3.1** All AEM support steel and guard steel should be in accordance with the design fabrication and erection of steel for buildings criteria contained in the AISC Specifications for Design.

**2.3.2** All weldments should be designed with allowable stresses in accordance with industry applicable standard ANSI/AWS D1.1.

**2.3.3** All field welding should conform to ANSI/AWS D1.1 Specification for structural welding code.

**2.3.4** Where powered hoists are used, an impact allowance should be included in design calculations for AEM vehicles, bridges, transfers and monorail supporting tracks. The impact allowance should be 1/2% of the rated lifted load for each foot per minute of hoisting speed with a minimum allowance of 15% and a maximum of 50%.

**2.3.5** Where two or more AEM vehicles operate on a monorail track, the maximum loading conditions on the monorail track runway should be defined by the AEM manufacture. The loading should consider positioning loaded AEM vehicles accumulated in line. Means are to be provided by the AEM manufacturer to prevent the vehicles from being positioned to exceed the design limitation.

## 2.4 Clearances

- 2.4.1 A minimum clearance of two inches should be provided between the AEM vehicle and any lateral or overhead obstruction not related to an AEM component such as track switch, hanger clamp etc.

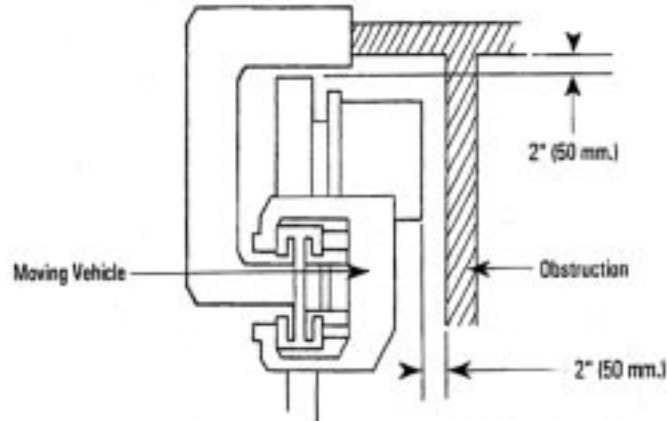

- 2.4.2 Clearance should be provided at the curves of an AEM system to allow for the swing of the load when the AEM vehicle negotiates a curve. Clearance should be determined by giving due consideration to the size, weight, load configuration and speed of the AEM vehicle when traveling through the curve radius.

- 2.4.3 Clearance should be provided between accumulated AEM vehicles, between the trailing edge of the carriers or load of a leading AEM vehicle and the leading edge of the carriers or load of a following AEM vehicle.

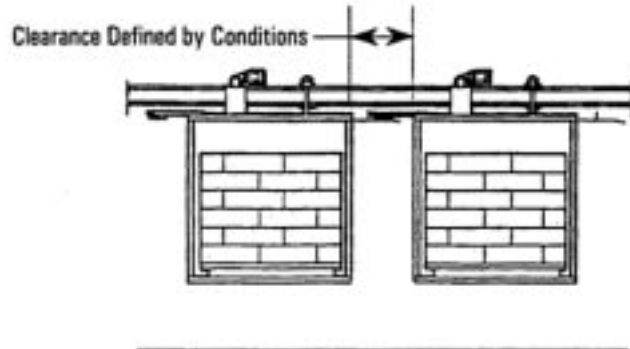

- 2.4.4 Clearance should be provided between the handrail and/or wall and a passing AEM vehicle, carrier or load to allow a minimum clear space of 20 inches (500mm) for maintenance personnel.

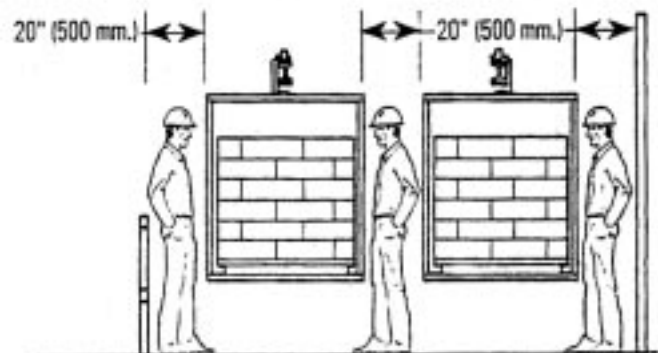

- 2.4.5 Clearance should be provided between two passing AEM vehicles, carriers, or loads to allow a minimum clear space of 20 inches (500mm) for maintenance personnel.

- 2.4.6** Clearance should be provided vertically between the bottom of an AEM carrier load and the top surface of the basket guard, floor or platforms. This minimum clearance should be 3".

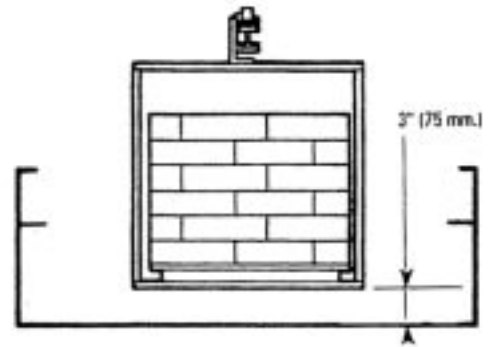

### **3.0 AEM TRACK**

- 3.1** AEM track section should be sized based on proposed carrying capacity, AEM vehicle configuration and scope of work.
- 3.2** AEM track should be capable of supporting the weight of the AEM vehicle, carrier, and the live load. Additional external loads should also be considered when applicable.
- 3.2.1** The maximum vertical deflection under full accumulated load should not exceed 1/300 of the span.
- 3.3** AEM track splices should be precision cut and should maintain vertical and horizontal alignment providing for a smooth transition from rail to rail.

### **3.4 Expansion Joints**

- 3.4.1** Expansion joints should be provided in the AEM track at building expansion joints. Expansion joints will be designed to assure smooth vehicle movement under all conditions.
- 3.4.2** Additional expansion joints should be added as required to accommodate temperature variation and to maintain sufficient track gap at switches, turntables, lifts and other moving track components.
- 3.4.3** Track hangers should be provided on each side of expansion joints. Spacing will be no more than 24" (1690mm) from the expansion joint.

### **3.5 Installation**

- 3.5.1** The AEM track should be accurately installed straight, level and square relative to the vertical and horizontal axis.
- 3.5.2** The track should be installed horizontally level and straight along the center line within 1/8" (3mm) measured at all track hangers. The track should maintain the vertical axis square within one degree of vertical.
- 3.6** Required falling parts guards, platforms, walkways, etc. should be attached to the building or support steel. Supporting external loads from the AEM track is not permitted.
- 3.7** The track should be supported by track hanger. The track hangers will be secured to the track with bolts or clamps. The track hanger will be attached to the building steel or support steel.

## 4.0 CONDUCTOR BARS

### 4.1 General

- 4.1.1 The conductor bars should be surrounded by an insulator. The insulator should allow the collector shoe to contact the conductor bar and also provide touch protection for individuals.
- 4.1.2 The conductor bar system will be designed such that normal wear occurs on the collector shoes rather than the bus bar.
- 4.1.3 The quantity of conductor bars will be based on system requirements and scope of work.

### 4.2 Conductor Bar Installation

- 4.2.1 The conductor hanger clamps should be connected to the track using bolts or a snap in anger. If bolted hangers are used, vibration proof, self-locking nuts should be used.
- 4.2.2 On short sections of conductor bars, such as on track switches and vertical lifts, the conductors will be secured to prevent them from being moved by the collector shoes on the AEM vehicle.
- 4.2.3 All burrs from the cut ends of conductor bar should be removed.
- 4.2.4 Cable connections to the conductor bars should be bolted or screwed on. Plug-in connections are not acceptable. All cable feeds should be covered so wiring is not exposed on the back side of the conductor bar. Zone splice boxes bolted to track should have a minimum of 24" (609.6mm) of flexible electrical cable attached for the possible future adjustment.
- 4.2.5 Isolation of zones will be accomplished by terminating the bar and using a lead-out piece, then a lead-in piece into the next bar. A gap will be provided to assure that residual metallic particles will not short the zones together. Inserts that could become coated with conductive residue are not acceptable.
- 4.2.6 The conductor bar system should accommodate track expansion joints.
- 4.2.7 The conductor bar system should account for the difference in thermal expansion between the conductor and the track.

## 5.0 SYSTEM TYPES

### 5.1 Type 1 System

Type 1 Systems are an AEM configuration including an section track with conductors mounted to the track web and top riding trolleys.

- 5.1.1 The top horizontal surface of the type 1 track will support the top running vehicle. The top and bottom guide surfaces should be perpendicular to the top of the track. Side guide surfaces should allow full contact of the vehicle trolley side guide rollers on straight track sections, horizontal and vertical curves.
- 5.1.2 Track mounted devices will be either bolted or clamped to the AEM aluminum track. No welding of components to the track will be permitted. Track mounted devices include track hangers, splice connections, and electrical control components.

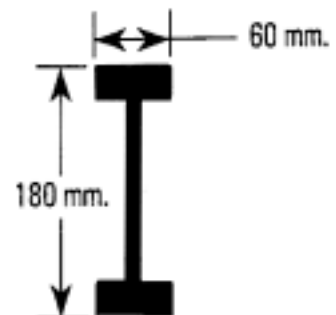

**5.2** Light Duty Type 1 track configuration should have a flange width of 2.362" (60mm) and a depth of 7.087" (180mm). Light duty track should have the capacity to support a minimum of 1100 lbs. (500kg) per single trolley or minimum 2200 lbs. (1000 kg) per double trolley.

**5.3** Heavy Duty Type 1 track configuration should have a flange width of 3.150" (80mm) and a depth of 9.449" (240mm). Heavy Duty Type 1 track should have the capacity to support 3000 lbs. (1300kg) per single trolley or 6000lbs. (2700kg) per double trolley.

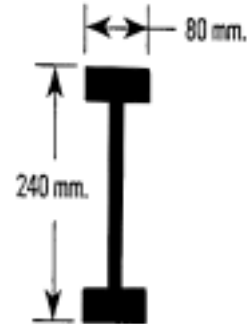

**6.0 AEM VEHICLES**

**6.1** The AEM vehicle should be used to transport the carrier and live load throughout the system. The vehicle may have a single drive trolley or multiple drive and idler trolleys. Vehicle trolley configuration will be per the application and scope of work.

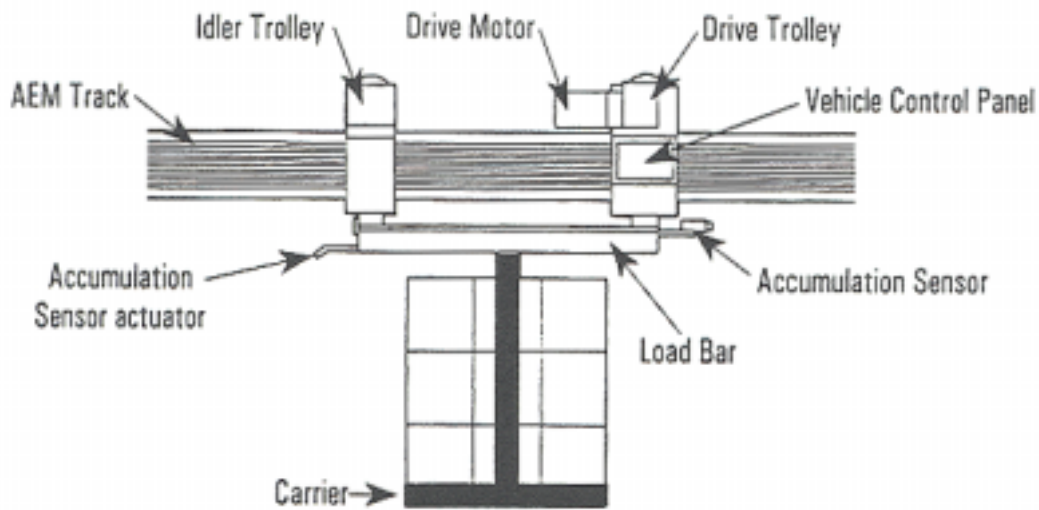

**6.2 Construction**

**6.2.1** Wheel bearings should have a minimum B-10 life of 5000 hours at 75% of the rated capacity.

**6.2.2** The trolley frame should employ fail safe construction in the event of load wheel loss, axle failure or guide roller damage, the trolley frame will support the vehicle and load from the track. The design of the vehicle will allow removal from the track at any point in the system.



## **6.3 Guide Wheels**

**6.3.1** The side guide wheels should stabilize and direct the vehicle along the AEM track.

**6.3.2** Type 1 guide wheel tread surfaces should be 90° to the drive wheel tread surface. These wheels should have ball bearing construction with a nonmetallic tread. The wheels will be mounted to the trolley frame and should be removable.

**6.3.3** Type 1 guide wheels should be pre-greased and permanently sealed.

## **6.4 Drive Trolley**

### **6.4.1 General**

The vehicle should be propelled by the drive wheel mounted on the drive trolley. The drive trolley consists of a motor, gear reduction unit and current collector shoes, drive wheel, guide wheels and trolley frame.

### **6.4.2 Drive Wheel**

The Type 1 drive wheel will contact the top of the AEM track. The drive wheel should support part of the load bar, carrier and live load to maintain sufficient friction. The drive wheel should have a nonmetallic tread.

### **6.4.3 Drive Motor**

The motor horsepower is to be determined based on total vehicle weight with carrier and maximum live load. The horsepower should allow a loaded vehicle to start at any position on the AEM track. The motor type, final horsepower and drive speeds will be determined by the application and scope of work.

### **6.4.4 Gear Reduction Unit**

The gear reduction unit should be designed to have a 1.5 service factor. The gear reduction ratio should be determined based on scope of work.

The gear reduction unit will be lubricated. The gear case should be properly sealed to prevent lubricant seepage onto loadbar and live load.

### **6.4.5 Motor Brake**

A motor brake to be used as a minimum for emergency stopping should be provided and mounted on the motor of each drive trolley. The brake should not be located on the output side of the reducer.

### **6.4.6 Type 1 Vehicle Clutch**

A clutch and external clutch actuation lever should be provided on each Type 1 drive trolley. The clutch will allow the vehicle to be manually moved in the event of drive unit failure or be pulled by a chain assist conveyer.

## **6.5 Drive Trolley Electrical**

### **6.5.1 Vehicle Control Panel**

The board control panel should be mounted on the vehicle in an easily removable enclosure. The onboard control panel should include the required controls for vehicle movement per the scope of work.

### **6.5.2 The controls on board the vehicle should include:**

- A means to disconnect power on board the vehicle**
- Power to the vehicle indicator light**

### **6.5.3 Collector Shoes**

Collector shoes will be provided to conduct electricity from the conductor bars to the drive trolley. The electrical power will be used for vehicle control, system communication and onboard device power.

These shoes should be spring-loaded and individually replaceable. The shoes should be provided with floating mounts to allow for negotiation of horizontal turns, vertical curves and irregularities in the conductor bar. Collector shoes should be placed near the vertical center line of the load wheel to minimize wear problems on horizontal turns and vertical curves.

### **6.5.4 Sensing Devices**

If a proximity switch is used for low speed accumulating it should be mounted on the front of the vehicle. The proximity switch mount should protect the switch from accidental contact with a preceding vehicle.

## **6.6 Idler Trolley**

### **6.6.1 General**

### **6.6.2 Idler Load Wheel**

The Idler Type 1 load wheel should have nonmetallic tread. The wheel will be equipped with a ball or roller bearings and will be mounted on an axle to the idler trolley frame. Bearings should be pregreased and permanently sealed.

## **6.7 Load and Tow Bars**

### **6.7.1 General**

Load bars and 3 tow bars should have sufficient strength and rigidity to maintain consistent trolley spacing and alignment.

### **6.7.2 Load bars should attach to the trolley frames with hardened steel pins and replaceable bearings or bushings. The connection pins should have a running fit with the replaceable bearings.**

## **7.0 AEM CARRIERS (LOAD FIXTURE)**

### **7.1 Each AEM vehicle will support a carrier (load fixture) which holds the live load. The actual design of the carrier will be based on the scope of work.**

## 7.2 Powered Carriers

7.2.1 Devices may include automatic or manually operated mechanisms as required by the scope of work.

7.2.2 Typical powered devices may include:

- Lift/lowers
- Powered Roller Beds

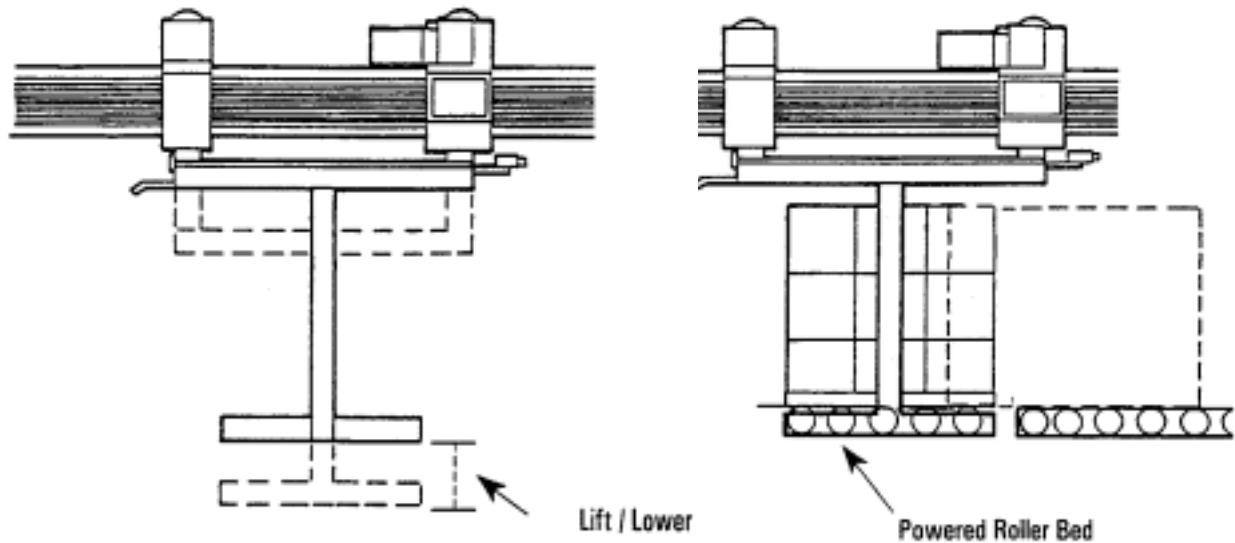

## 8.0 AEM HORIZONTAL TURNS

### 8.1 General

AEM horizontal turns should be rolled or bent from the same cross section as the straight track.

The Type 1 minimum horizontal turn radius is 750mm and in general the chordal dimension of a 90° turn should be equal to or greater than the maximum vehicle trolley centers.

### 8.2 Installation

In order to minimize track movement due to vehicle travel around the turn cross bracing or another suitable method may be required.

## 9.0 AEM TRACK SWITCHES AND TURNTABLES

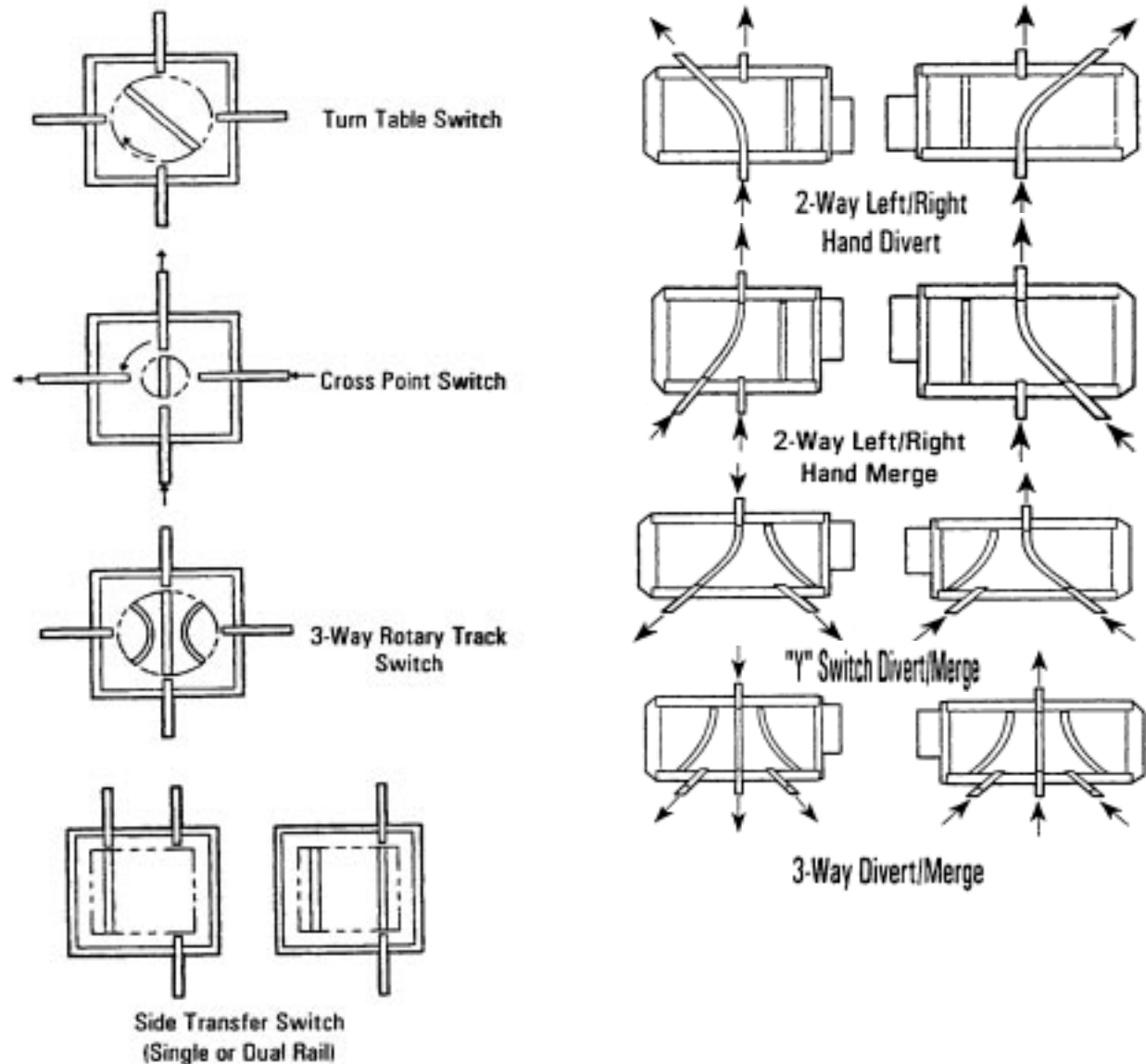

### 9.1 General

AEM track switches are utilized for routing AEM vehicles to various destination points. This is typically done by means of a moveable rail section.

### 9.2 Construction

- 9.2.1 All track switches should be constructed and installed to maintain alignment with incoming and outgoing track.
- 9.2.2 Stops should be provided as an integral part of the track switch to block the end of an incoming track when the switch track is not aligned with the incoming and outgoing track.
- 9.2.3 Standard 2-way and 3-way type track switches should not be shifted with an AEM vehicle on the moveable track.

**9.2.4** Means should be provided to hold the moveable frame in a stationary position during passage of an AEM vehicle through the track switch.

## **10.0 AEM INCLINE AND DECLINE TRACK**

**10.1** The AEM incline (and decline) track allows the AEM vehicle to travel from one elevation to another. The curve track should be made from the same profile as the AEM straight track.

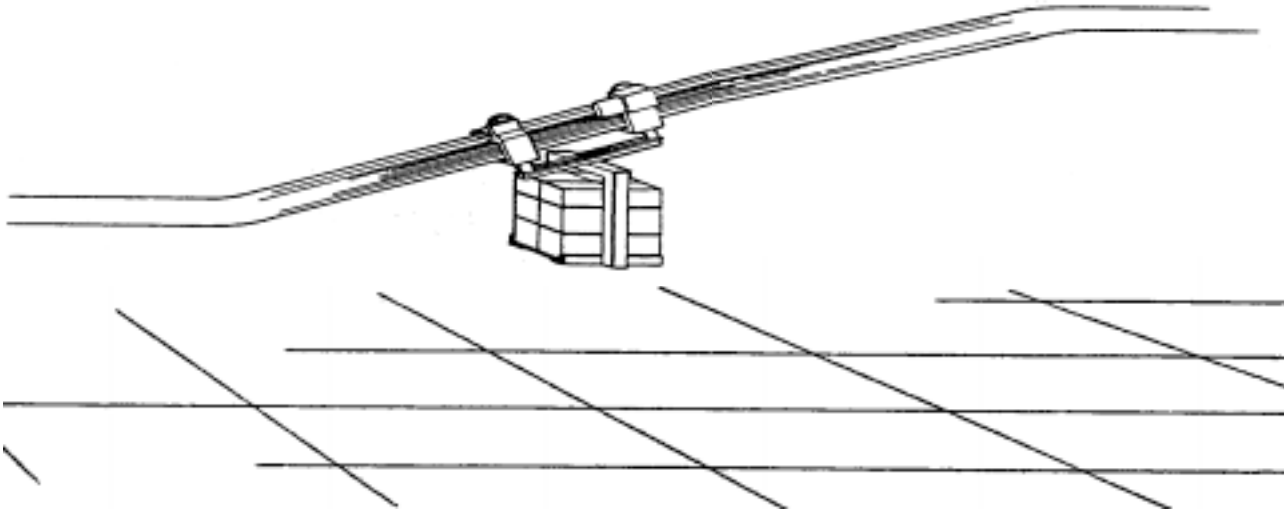

**10.2** The minimum radius of the vertical curve should allow adequate vehicle and trolley clearance through the curve. The trolley side guide wheel should not lose apparent contact with the track guide roller surface while traveling through the curve. The minimum design vertical curve radius should allow the curve to be manufactured without exceeding the safe limits of the design properties of the cross section and of the materials.

**10.3** Systems with incline track should have proper vehicle horsepower and brakes for starting and stopping on the slope. Under normal operation conditions sliding while stopping on the declines is not allowed. Under emergency stop conditions sliding should be minimized.

**10.4** On both incline and decline track sections the need for safety devices should be determined by the scope of work. If required, safety devices should be designed to overcome uncontrolled vehicle movement down the incline or decline track section.

## **11.0 AEM ANTI-BACK-UP DEVICE (ON INCLINE TRACK)**

### **11.1 General**

Track mounted anti-back-up devices will prevent a failed vehicle from rolling backward on an incline track section. The device should be able to withstand the impact of a loaded vehicle bringing the loaded vehicle to a stop.

### **11.2 Anti-Back-Up Device Location**

When anti-back-up devices are required, they should be placed according to the scope of work.

## 11.0 AEM ANTI-BACK-UP DEVICE (ON INCLINE TRACK)

### 11.1 General

Track mounted anti-back-up devices will prevent a failed vehicle from rolling backward on an incline track section. The device should be able to withstand the impact of a loaded vehicle, bringing the loaded vehicle to a stop.

### 11.2 Anti-Back-Up Device Location

When anti-back-up devices are required, they should be placed according to the scope of work.

## 12.0 AEM ANTI-RUNAWAY DEVICE (ON DECLINE TRACK)

12.1 An anti-runaway device should prevent a failed AEM vehicle from rolling down a vertical curve decline track section without control. The device should be able to withstand the impact of a loaded vehicle, bringing the loaded vehicle to a stop. The device should operate in a fail safe condition.

### 12.2 Anti-Runaway Device Location

When anti-runaway devices are required they should be placed according to the scope of work.

## 13.0 AEM VERTICAL DROP OR LIFT SECTIONS

### 13.1 General

AEM vertical lift units allow AEM vehicles to change elevation. The lift carriage will support the lift track section, AEM vehicle, carrier, and live load. The lift track will be the same configuration as the standard AEM track.

13.2 Vertical drop or lift sections should maintain alignment of the fixed tracks and the movable tracks to enable the passage of a vehicle.

13.3 Means should be provided to prevent a vehicle from running off either end of the movable track when the movable track is not in alignment with the fixed tracks.

13.4 Stops should prevent a vehicle from running off the open ends of the fixed tracks when the movable track is not in alignment with the fixed tracks.

### 13.5 Installation

If lift stations are attached to the building, the lift and support design should take into consideration the possible movement of building steel.

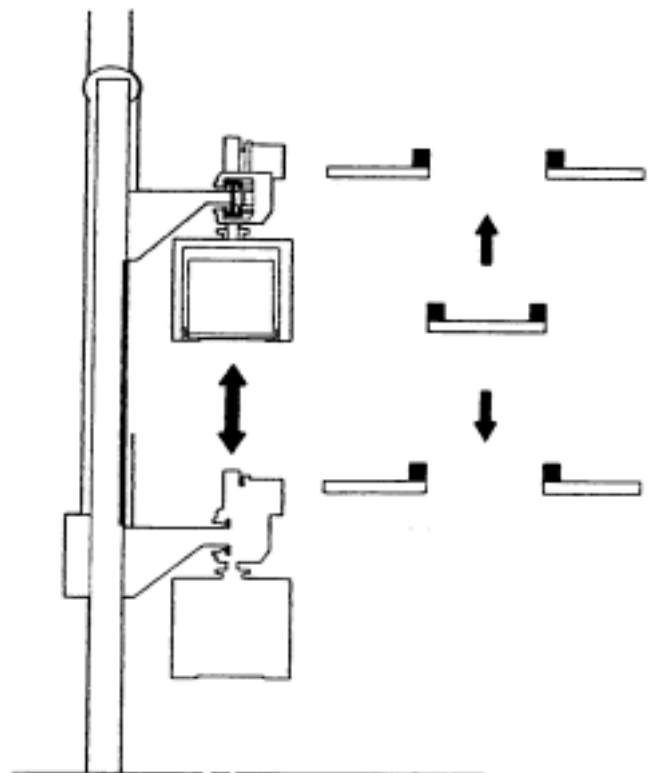

## **14.0 MAINTENANCE SPUR**

**14.1** The maintenance spur is an area within a system where maintenance is performed on the AEM vehicle. Typically there are two types of maintenance spurs that are utilized in an AEM system. The first type has entrance and exit track switches to allow the vehicles to enter and exit the main system. The second type has one track switch which allows the vehicle to enter and exit the main system.

## **15.0 DEAD END SPURS**

**15.1** A mechanical stop should be provided to prevent a vehicle from running off an open end of track.

## **16.0 CONSIDERATIONS FOR AEM DIAGNOSTICS**

**16.1** Several options are available for the purposes of monitoring and/or obtaining diagnostic information for an AEM system. The system(s) can be monitored from a central location (either plant floor or control room environment), from several locations closer to the equipment or at the actual equipment itself. Tools used to accomplish this include PC based graphics packages, indicator light panels, message displays, etc. Some factors determining the methods used include budget constraints, size of the AEM system, and environment of the installed system.

Information exists at both the off-board and on-board (vehicle) locations which can be helpful to the user. Benefits of displaying and/or gathering this data could include; increased responsiveness to faulted conditions, providing current system activity and equipment status information, reductions in equipment downtime, assisting maintenance personnel by quickly providing troubleshooting information, etc.

### **16.1.1 Typical on-ground information that could be obtained:**

- AEM system mode status (auto, manual, E-Stopped, etc.).
- Track switch mode, position and fault status.
- Current vehicle locations and tracking information including: Zone location, vehicle ID, Load ID, loaded/unloaded status of vehicle, etc.
- Locations throughout the system containing stalled/faulted AEM vehicles.
- Lift equipment mode, position and fault status.
- Collector shoe wear status.
- Bar code scanner status and performance information.

### **16.1.2 Typical Vehicle on-board information that could be obtained:**

- Vehicle mode status (auto, manual, faulted, etc.)
- Vehicle present circuit active/faulted status.
- Speed command status from off-board controller.
- Motor overload tripped.
- Drive status information.

### **16.1.3 Vehicle Run**

Many of today's Variable Frequency Drives (VFD's) provide some form of diagnostics, such as a numeric fault code indication, pulsed LED indicators, etc. These provide detailed drive diagnostics: under/over voltage conditions, ground fault, microprocessor fault, over current conditions, etc.

**16.1.4** The above items are not completely inclusive of all diagnostic information obtainable from an AEM system, but are presented in order to provide a general guideline as to some of the information and tools available when considering AEM diagnostics.

## 17.0 TERMS AND DEFINITIONS

- 17.1 ACCUMULATION SENSOR ACTUATOR** - An actuation surface which provides the means for triggering the accumulation sensor on the following vehicle.
- 17.2 AEM** - Automated Electrified Monorail describes a conveying system which consists of monorail track, track mounted electrification, individually powered vehicles, a supporting structure, a control system, lifts switches and turntables as is necessary.
- 17.3 AEM VEHICLE** - An assembly consisting of vehicle on board controls, drive trolley, idler trolley (if required) and the load bar connecting the trolleys. The vehicle supports the carrier and live load.
- 17.4 ANTI-BACK-UP** - A mechanical safety device mounted on a vertical incline, to prevent reversal of a loaded carrier under action of gravity when forward travel is interrupted.
- 17.5 ANTI-RUNAWAY** - A safety device mounted on a vertical decline to stop a carrier and thus prevent runaway in the event of an electrical or mechanical failure.
- 17.6 CARRIER** - The load carrying fixture supported by the AEM vehicle.

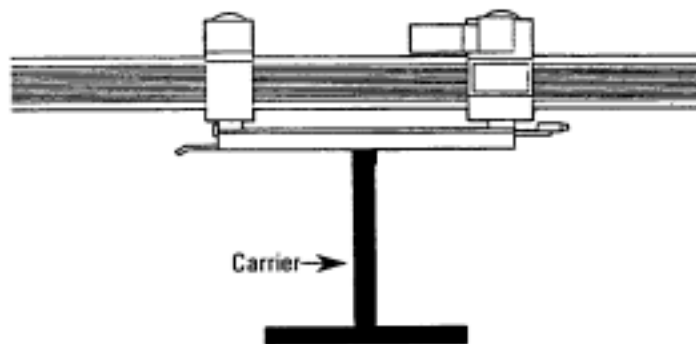

- 17.7 COLLECTORS** - Electrical contacting devices providing a path for current flow from stationary conductor bars to moving equipment.
- 17.8 CONDUCTOR BARS** - Track mounted insulated bar used to transmit electric current to the vehicle.
- 17.9 DRIVE TROLLEY** - A motor-driven trolley which propels the vehicle.
- 17.10 HORIZONTAL TURNS** - Formed or fabricated sections of track used to change the horizontal direction of vehicle travel.
- 17.11 INCLINE/DECLINE CURVES** - Formed or fabricated sections of track constructed to change direction of the path in a vertical plane.
- 17.12 IDLER TROLLEY** - A non-motorized trolley.



**17.13 LIVE LOAD** - The product or other applied load which is to be transported by the AEM vehicle/carrier, including any container pallet, basket, tub, etc.

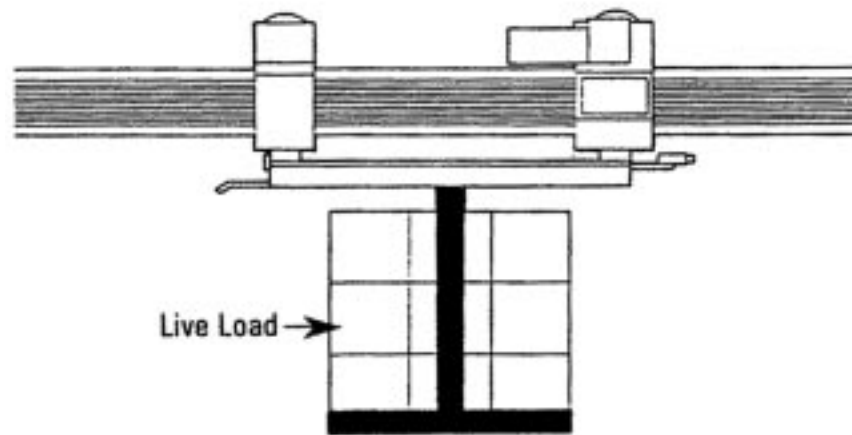

**17.14 LOAD BAR** - A Structural member connecting two trolleys and supporting the carrier.

**17.15 RATED LOAD** - The maximum fully loaded vehicle weight designated by the manufacturer for which the AEM system is designed and built.

**17.16 TRACK SWITCH** - A device used to merge or diverge track paths.

**17.17 TRACK** - Profiles upon which the AEM vehicles operate.

**17.18 TRACK HANGER** - A component of the AEM system which mechanically connects the AEM track to its supporting structure.

**17.19 TRACK TURNTABLE** - A track device containing section(s) of track which can be rotated with a loaded vehicle on it to align the track with other tracks used for routing of vehicles from one track to another.

**17.20 TRACK DROP/LIFT SECTION** - A mechanism which permits a section of track(s) to be lifted or lowered in order to align one track with a track at another elevation.

**17.21 TOW BAR** - A Structural member connecting two trolleys but supporting no other load.

**17.22 VARIABLE FREQUENCY DRIVE (VFD)** - An electronic device that controls the speed, torque and direction of an AC motor.

# What is MMA?

## What is MMA?

Founded in 1933, the **Monorail Manufacturers Association, Inc. (MMA)** is an independent incorporated trade association affiliated with the Material Handling Industry. MMA Member Companies produce the preponderance of patented and enclosed track underhung cranes and monorail systems. MMA operates through committees with programs and policies reviewed and adopted by the membership with representation from each member company. Its many activities include an active engineering committee. MMA is represented on a number of standards developing committees and actively support the development and certification of safety standards by the ANSI consensus method.

## MMA Mission

Our Mission is to deliver real value to our members, channel partners, consumers and users by:

- Driving demand for products and services
- Delivering education and professional development programs
- Creating a forum for collaboration
- Promoting safety and proper monorail applications
- Making membership compelling

## MMA Vision

**MMA** is recognized as the leading authority and a principal resource in the overhead material handling industry. MMA is recognized as the leading advocate for the safe application and operation of enclosed track, patented track and automated electrified monorail equipment, systems and related products. MMA members are the recognized leaders in the marketplace and the subject matter experts. We will achieve this by:

- Delivering superior value in our products and services
- Providing products and services that are safe and productive.
- Proving high value solutions directly through knowledgeable and expert channel partners.
- Providing an environment in which our customers can confidently purchase and derive superior value from our products.



# Value Statement

What is the value of membership in the **Monorail Manufacturers Association, Inc. (MMA)**?

1. Market Intelligence Information:
  - a. Unit and volume statistics program
  - b. Market forecasts and economic indicator monitoring
  - c. Industry forecasts
  - d. Geographic product distribution and planning data, workshops
  - e. Channel partner planning workshops
  - f. Trend monitoring
  - g. Planning and forecasting tools, workshops
2. Members Professional Development
  - a. Leadership development
  - b. Multi-topic educational series
  - c. Networking throughout the industry
  - d. Peer to peer interaction
3. Promotion of the Safe Use of our Products
  - a. Development of product standards
  - b. Development of maintenance and service inspection manuals
  - c. Development of proper hoist usage documents
  - d. Alliance program with OSHA to promote safety
  - e. Tip and Fact Sheets for OSHA distribution
4. MMA Members are recognized as the Market's Leaders; MMAI Members:
  - Are Speakers and Education Subject Experts
  - Provide Engineering Specification and Standards Input
  - Publish a Compendium of Product Standards
5. Increased Exposure to Customers
  - Web-based Case Studies provide Market Solutions to Users
  - MHIA Website channels customers to MMA members
  - MMA Certified Program Increases Product Value

Participation in **MMA** can increase your business levels, increase your exposure in the marketplace, develop your employees, help your corporate decision-making, increase safe usage of your products, and position you as one of the leaders in the monorail industry.



For information regarding membership, standards, specifications, market research initiatives, industry statistics, literature or publications. MMA Managing Director Hal Vandiver: [hvandiver@mhia.org](mailto:hvandiver@mhia.org)  
Executive Assistant Cathy Moose: [cmoose@mhia.org](mailto:cmoose@mhia.org)

## **MMA**

8720 Red Oak Blvd., Suite 201  
Charlotte, NC 28217-3992  
Phone: 800-345-1815 / 704-676-1190 Fax: 704-676-1199  
URL: [www.mhia.org/mma](http://www.mhia.org/mma)

Call the Material Handling Institute Literature Department at 800-345-1815 or 704-676-1190 or go to [www.mhia.org/mma](http://www.mhia.org/mma) , “Publications and Resources”, to order the following MMA publications:

---

### **MH27.1 - 2009- Specifications for Patented Track Underhung Cranes and Monorail Systems**

Approved and published in 2009, this publication was developed by the Monorail Manufacturers Association, Inc. to assist manufacturers and users of underhung cranes and monorail systems. This specification was originally approved as an MMA consensus standard in 1973, was subjected to the ANSI Canvass Review Process, and is now available as an American National Standard. Includes discussion of curves, switches, transfer devices, trolleys, lift and drop sections and associated equipment. FREE DOWNLOAD

### **MH27.2 - 2009 - Specifications for Enclosed Track Underhung Cranes and Monorail Systems**

Approved and published in 2009, this standard was sponsored by the Monorail Manufacturers Association, Inc. in the interest of improved uniformity of underhung crane and monorail performance and enhanced public safety. This standard, that was developed under the ANSI Canvass method and approved by ANSI on September 10, 2003, represents suggested design practices and performance testing criteria for crane and monorail equipment. It was developed with the sole intent of offering information to parties engaged in the manufacture, marketing, purchase, or use of crane and monorail equipment. FREE DOWNLOAD

### **Guidelines for Specifying AEM Systems**

These Guidelines have been developed by the member companies of the Automated Electrified Monorail (AEM) Product Section of the Material Handling Institute, a division of the Material Handling Industry (MHI), which is comprised of leading suppliers of Automated Electrified Monorail systems in North America.

Their purpose is to act as a guide in the selection, design, planning and implementation of Automated Electrified Monorail Systems. FREE DOWNLOAD

### **Recommended Practices – Workstation Cranes and Patented Track Systems**

The Monorail Manufacturers Association (MMA), an association affiliated with Material Handling Industry, has produced recommended Practices of Workstation Cranes and Patented Track Systems. Because the manufacturer has no direct control over the workstation crane or patented track system and its operation, conformance with good safety practice is the responsibility of the owner, the user and the operating personnel. ANSI/ASME B30.16, ASME B30.11-2004, ANSI MH27.1 and MH27.2 have been used as a guide in preparing this list of SHALL's and SHALL NOT's. Shall's and Shall Not's are each one page and handy for posting on bulletin boards or in areas where hoists are used. FREE DOWNLOAD



**Members of the Monorails Manufacturers Association, Inc.**

**Acco Material Handling Solutions**  
P.O. Box 792  
76 Acco Drive  
York, PA 17405-0792  
(800) 967-7333  
[www.accomhs.com](http://www.accomhs.com)

**Ingersoll-Rand Company**  
P.O. Box 970  
1467 Route 31 South  
Annandale, NJ 08801  
(908) 238-7000  
[www.irco.com](http://www.irco.com)

**Columbus McKinnon Corporation**  
140 John James Audubon Parkway  
Amherst, NY 14228  
(716) 689-5400  
[www.cmworks.com](http://www.cmworks.com)

**SPANCO, Inc.**  
Morgantown Business Park  
604 Hemlock Road  
Morgantown, PA 19543  
(800) 869-2080  
[www.spanco.com](http://www.spanco.com)

**Demag Cranes & Components Corp.**  
29201 Aurora Road  
Solon, OH 44139  
(440) 248-2400  
[www.demag-us.com](http://www.demag-us.com)

**TC American Monorail, Inc.**  
12070 43<sup>rd</sup> Street N.E.  
St. Michael, MN 55376  
(763) 497-7000  
[www.tcamerican.com](http://www.tcamerican.com)

**Gorbel, Inc.**  
600 Fishers Run  
P.O. Box 593  
Fishers, NY 14453  
(800) 821-0086  
[www.gorbel.com](http://www.gorbel.com)

**United States Monorail,  
Division of American Cranes**  
1234 Washington Street  
Boston, MA 02118  
(800) 343-2252  
[www.ac-h.com](http://www.ac-h.com)