

Application Guidelines for Ergonomic Assist and Safety Equipment

Published By

E.A.S.E. Ergonomic Assist and
Safety Equipment

Price: \$8.00

Table of Contents

Introduction—Manual Lifting, Material Handling and Ergonomics	Page 2
Ergonomic Assist and Safety Equipment (E.A.S.E.) Council	Page 3
Major Regulations Affecting Ergonomics	Page 3
Ergonomic Assist and Safety Equipment in a Manufacturing/Assembly Environment	Pages 4-5
Ergonomic Assist and Safety Equipment in a Warehouse/Distribution Environment.....	Pages 6-7
Ergonomic Motion Classifications	Page 8

Purpose

These Application Guidelines for Ergonomic Assist and Safety Equipment have been developed by the member companies of the E.A.S.E. Council of Material Handling Industry (MHI) to offer guidance to those considering ergonomic assist and safety equipment.

Disclaimer

The Guidelines are advisory only. They have been promulgated by the member companies of the E.A.S.E. Council of MHI with the sole intent of offering information for the parties engaged in the consideration of ergonomic assist and safety equipment. Reference to the Guidelines in inquiries by the purchaser is permissible. The Guidelines are not intended to and do not in any way limit the prerogative of a manufacturer to design or produce ergonomic assist and safety equipment. Whenever mandatory or other language used in the Guidelines seems to impose requirements, same is intended to be advisory only.

E.A.S.E. and MHI make no warranties whatsoever in connection with these guidelines. They specifically disclaim all implied warranties of merchantability or of fitness for particular purpose. No warranties (express, implied or statutory) are made in connection with these guidelines.

Users of the guidelines specifically understand and agree that E.A.S.E., MHI, their officers, agents and employees shall not be liable in tort and in contract—whether based on warranty, negligence, strict liability, or any other theory of liability—for any action or failure to act in respect to the design, erection, installation, manufacture, preparation for sale, characteristics, features or delivery of anything derived from, or covered by, these guidelines. By employing or otherwise referring to these guidelines, it is the user's intent and understanding to absolve and protect E.A.S.E., MHI, their successors, assigns, officers, agents and employees from any and all tort, contract or other liability.

Introduction

Manual Lifting, Material Handling and Ergonomics

Despite the tremendous advances in technology over the last thirty years, a significant portion of American industry routinely handles materials without the benefit of ergonomic assist equipment or devices. As a result of this, lower back disorders and even disability continue to be a primary source of loss to American industry. In fact, the costs to American industry for injuries caused by lower back pain in 1992 was over 11 billion dollars. If this isn't bad enough, consider the following statistics from the Bureau of Labor Statistics:

- **Lost time from job related injuries totals 105 million work days each year.**
- **Manual materials handling represents an estimated 35% of total workers' compensation claims.**
- **Medical expenses, lost wages, lower productivity, and other expenses from these injuries amounts to \$116 billion annually.**
- **Back injuries account for 20% of all compensation claims according to various studies.**

Although the basic concept of ergonomics has been around for many years, the skyrocketing costs and the human suffering associated with lower back injuries and commulative trauma disorders has made ergonomics a major topic of interest today. Ergonomics, the science of designing work to fit the capabilities of workers, can be instrumental in improving a company's productivity.

Today, organizations who are ignoring ergonomics are experiencing increased costs as a result of this. Unions have negotiated clauses to implement ergonomics into their contracts. The Occupational Safety and Health Administration (OSHA) has cited companies for failing to implement ergonomic solutions that will protect their employees. Products

designed to reflect proper ergonomic principles are advertised more frequently, because such designs are perceived as a marketing advantage.

The materials handling industry has long understood the importance of ergonomics in the design of jobs and equipment. Realizing the importance of the ergonomics issue, many of the leading manufacturers of material handling equipment have already taken a very aggressive approach to either redesign traditional equipment or develop new products.

The redesign of traditional equipment such as powered and manual lift trucks, orderpicking rack systems, conveyors, containers, and workbenches has not only reduced ergonomic problems but has also increased industry's awareness level as to the opportunities for new savings.

Exciting new equipment designed specifically with ergonomics in mind includes industrial manipulators, lift tables, workstation cranes, positioners and balancers, vacuum assist devices, pallet stackers, and tilt tables. The formation of an Ergonomics Assist and Safety Equipment (E.A.S.E.) Council within the Material Handling Industry reflects the ongoing commitment of leading manufacturers to collectively address the issue of ergonomics in material handling.

Ergonomics will continue to be a major opportunity for the material handling industry and to planners of manufacturing, warehousing and distribution systems. Proper ergonomics in these systems today increases production and quality along with decreasing medical costs, injuries, labor turnover and absenteeism. These are contributing factors to the material handling industry's sustained leadership in the global market.

Major Regulations Affecting Ergonomics

It's called the Ergonomic Protection Standard (EPS), proposed by OSHA, and it's aimed at reducing work related musculoskeletal disorders—the kind that adversely affect workers when they lift, push or pull too much, too often or handle too heavy a load. The standard, as originally proposed, would:

- Identify risk factors;
- Control risk factors in problem jobs;
- Evaluate the effectiveness of controls in reducing the risk factors.

The overall strategy is job analysis and job improvement with a scoring method that should be less complicated than the lifting formulas being proposed for the new NIOSH Lifting Guideline.

Additionally, the Americans with Disabilities Act (ADA) is putting further pressure on industry to provide reasonable accommodation for employees with disabilities. Who is disabled and what is reasonable? This will undoubtedly be settled in the courts through the thousands of cases already filed. In any case, ADA is sweeping civil rights legislation and it will affect the American work place. Workstations will have to be modified to accommodate workers with disabilities.

Today's work place is changing, not only because of laws, but because the benefits and improvements of Ergonomics are about "People" —keeping employees healthy while improving productivity.

Of all the many occupational health issues that face industry today, back disorders rank as the most costly in both direct Workers' Compensation pay outs and the cost of lost time. Despite all that has been written on effective occupational health and welfare, and the countless safety programs that have been tried, back disorders continue to increase. Five million workplace injuries are reported each year, of which approximately 1.2 million are back related disorders, according to the Bureau of Labor Statistics. This costly plague has reached proportions that are affecting the growth and vitality of many American industries.

In an increasingly competitive market place, costs cannot rise in direct proportion to sales. Holding down business costs whether they be insurance (Workers' Compensation), lost time or the cost of retraining are all costs that can be, and must be controlled if we intend to stay viable in the global market place. Unlike many of the other costs of doing business the cost of back disorders, whether those be single event injuries or the more prevalent Cumulative Trauma Disorders (CTDs) are manageable.

In addition to all the direct and indirect costs to industry associated with back related trauma, we have more recently seen OSHA citing ergonomic violations as "willful." Such citations can carry higher penalties. Presently companies are being cited under the general duty clause of the Workplace Safety Act or ANSI-Z365 Ergonomics Standard on Cumulative Trauma Disorders. Industry can no longer ignore the reasonable application of ergonomics to the work place, it is no longer just the smart thing to do; it is becoming law.

Ergonomic Assist and Safety Equipment (E.A.S.E.) A Council of Material Handling Industry

In 1994, a group of visionary leaders came together to form the Ergonomics Assist and Safety Equipment (E.A.S.E.) Council. These manufacturers of material handling equipment have a stated mission to broadly promote the benefits of ergonomic assist systems and equipment together with the advantages derived from the use of this equipment in the workplace. In addition, the mission statement includes promoting the general safety and health aspects of work environments for people with or in the vicinity of mechanical equipment.

Since its formation, the E.A.S.E. Council has sponsored numerous conferences and workshops designed to promote a

better understanding of how ergonomics and material handling can be combined to increase productivity and maximize employee health and safety. Publications like "A Guide to Ergonomic Assist and Safety Equipment" will continue to be developed as part of an ongoing education program of E.A.S.E.

E.A.S.E. is a council of Material Handling Industry. Information can be obtained by writing, calling or electronically accessing via the Internet and World Wide Web. Address details can be obtained on the back cover of this brochure.

Manufacturing/ Assembly Environment

PAINT SHOP

"Run that by again!"
NO LIFE
REBUILT PARTS
for
•AUTO•TRUCK•MARINE

⚠
DANGER

(3)

(1)

(2)

(7)

(6)

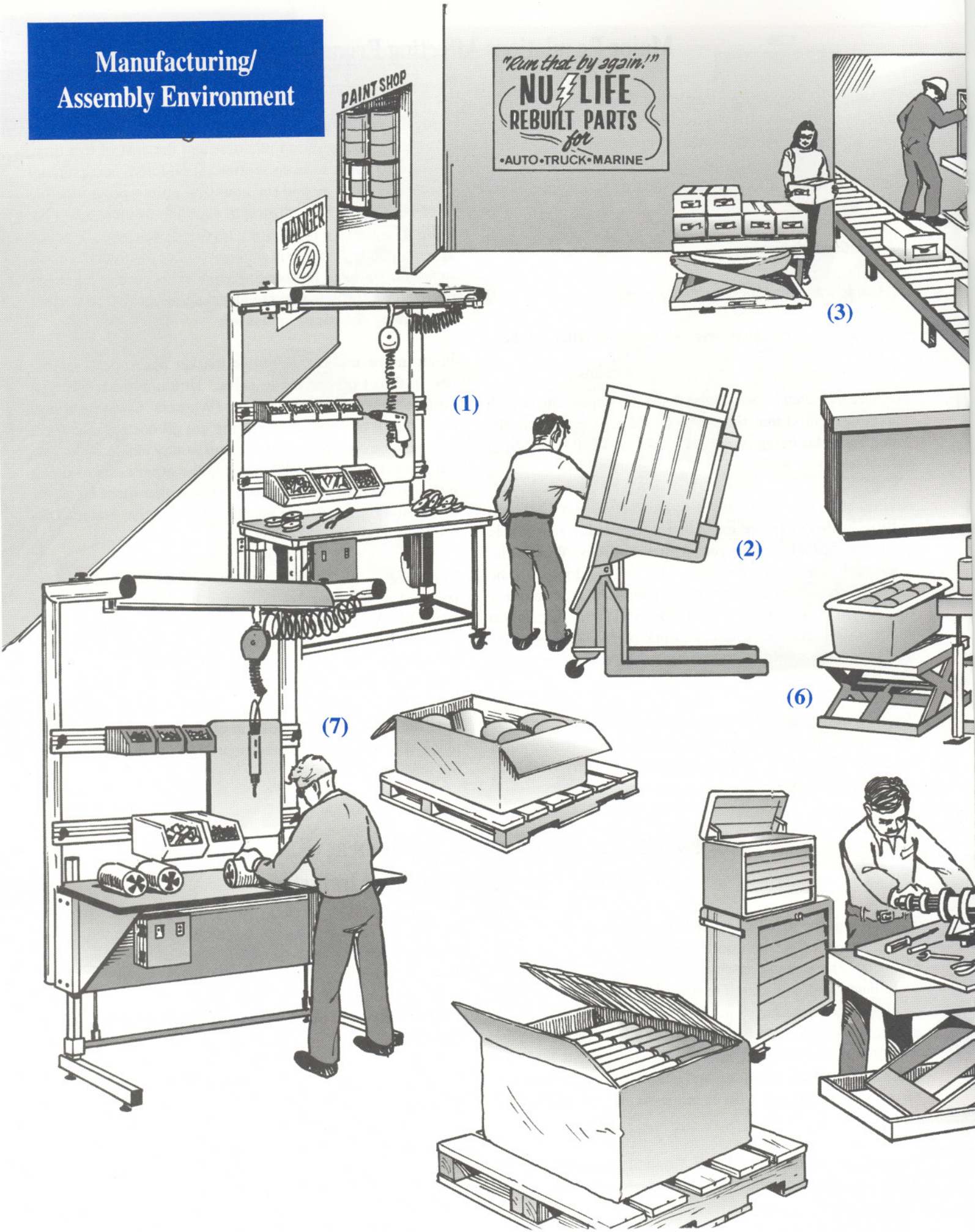

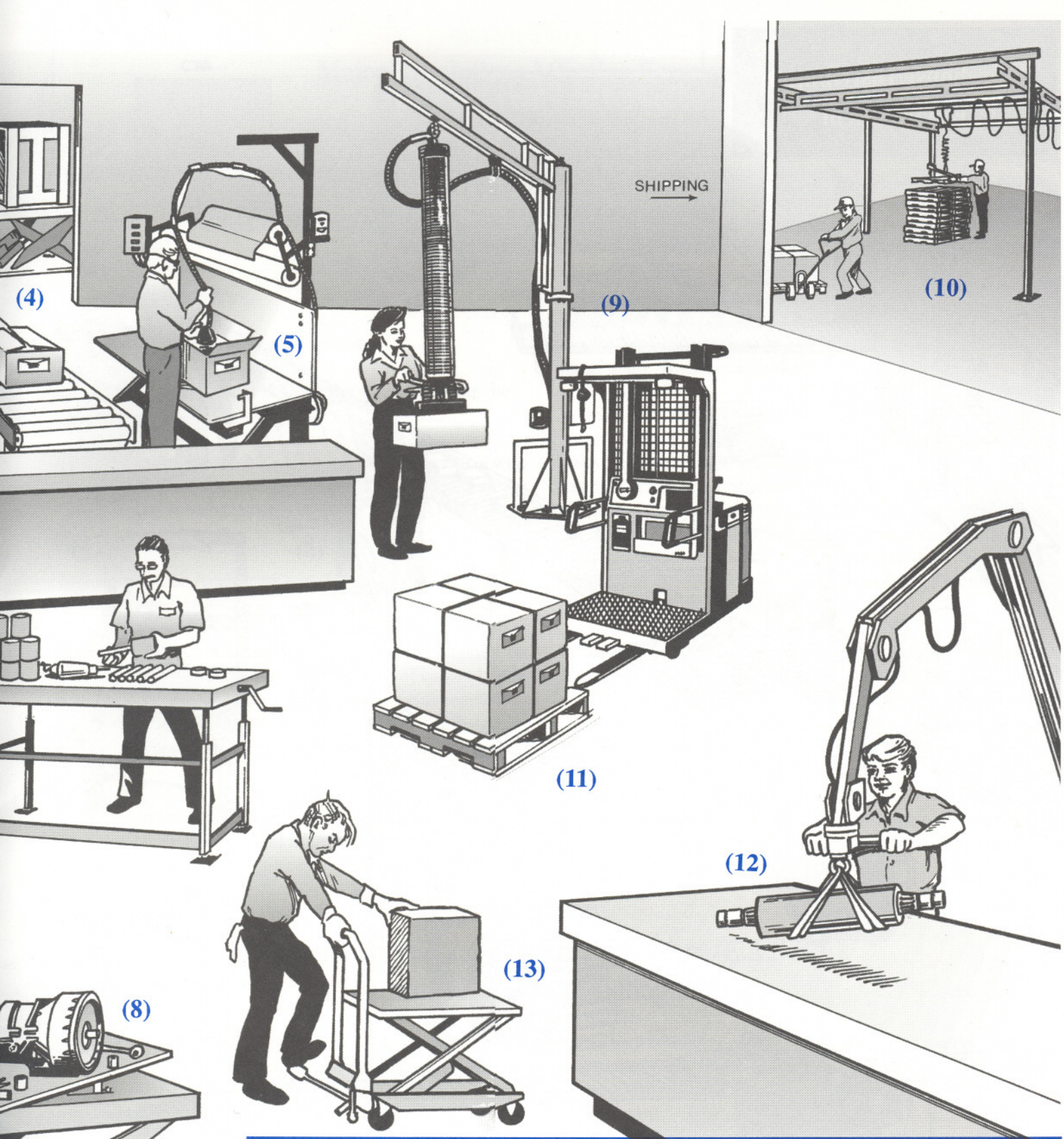

- (1), (5), (7) **Adjustable Workstation**—Enhances productivity by adjusting to the worker.
- (2) **Container Tilter**—Transports the load and positions container for optimum loading/unloading.
- (3) **Pallet Positioner**—Keeps pallet positioned to minimize worker bending/stooping.
- (4), (6), (8) **Industrial Scissors Lifts**—Position load for best accessibility by worker.
- (9) **Workstation Crane with Vacuum Assist Device**—Helps lift and position bulky loads with minimal effort
- (10) **Workstation Crane and Balancer**—Makes transporting and positioning pallets effortless.
- (11) **Stackers**—Allow loads to be positioned and stored with ease.
- (12) **Industrial Manipulators**—Assist with placement and positioning of heavy and awkward loads.
- (13) **Mobile Scissors Lift**—Transport and position loads.

- (1) **Industrial Scissors Lifts**—With a roller swivel top for transferring.
- (2) **Adjustable Worker Elevation Platform**—For order picking.
- (3) **Industrial Scissors Lift**—Elevates work piece.
- (4) **Pallet Rotator**—Eliminates manual stacking/unstacking of loads.
- (5) **Container Tilter**—Transports load and positions container for easy loading/unloading.
- (6) **Stacker with Industrial Scissors Lift**—Helps position worker and pallet for order picking.
- (7) **Workstation**—Totally adjustable to maximize packaging productivity.
- (8) **Workstation Crane with Balancer**—Provides assistance in stacking pallets.
- (9) **Pallet Positioner**—Keeps pallet at an ideal position for loading/unloading.
- (10) **Mobile Industrial Scissors Lift**—Transport and position load.
- (11) **Expandable Conveyor**—Provides efficient means of loading/unloading trailers.

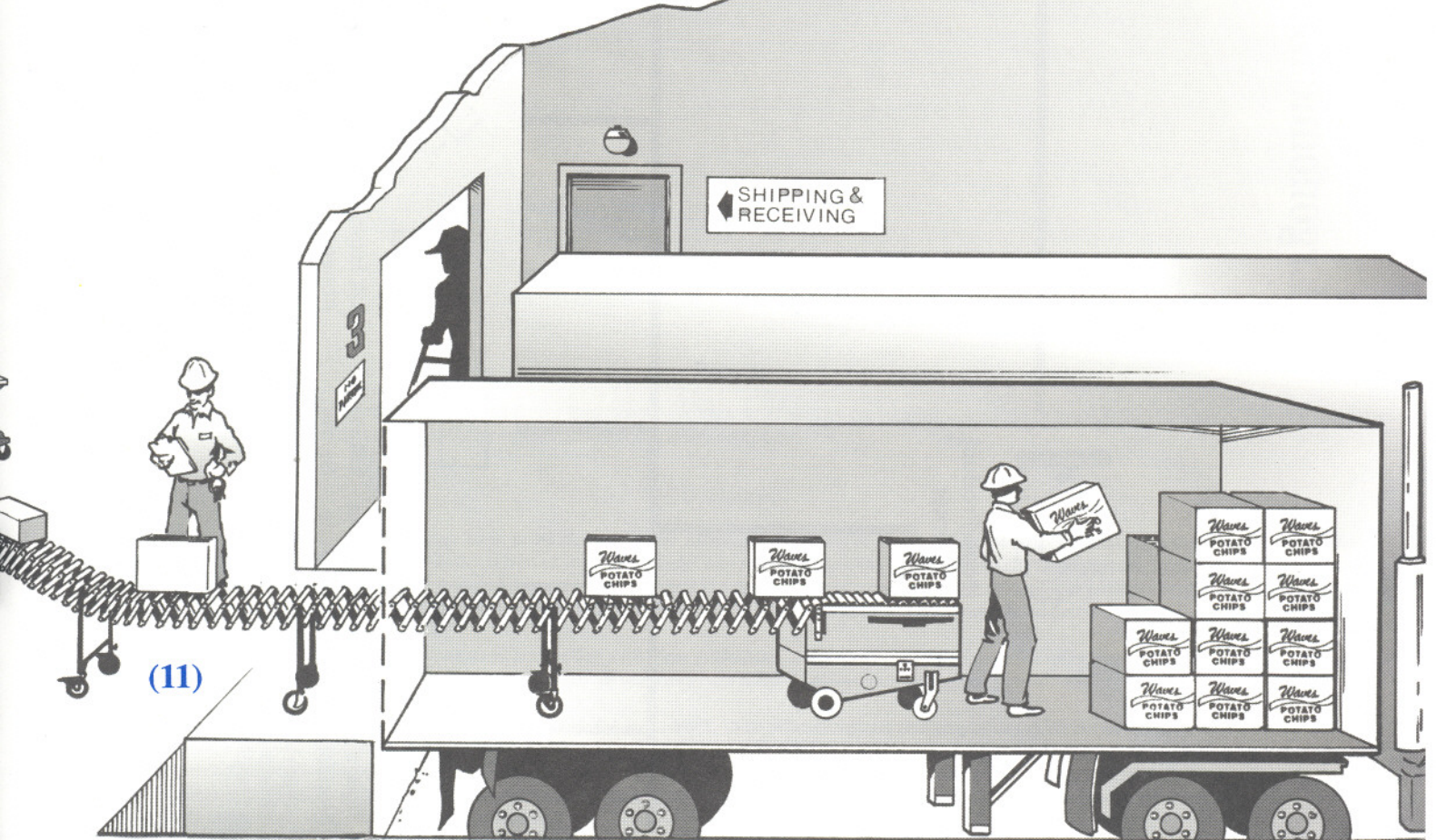
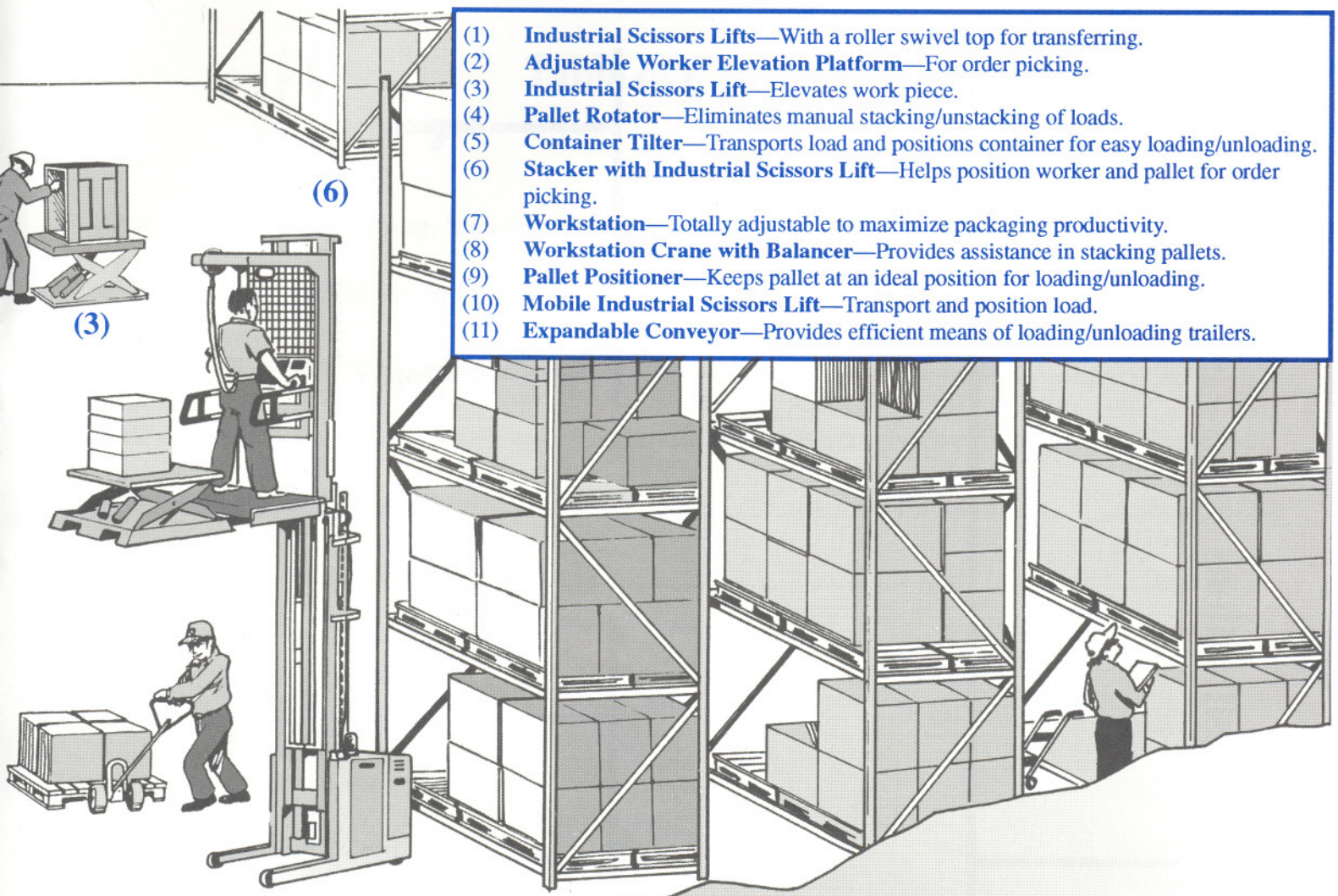

Ergonomic Motion Classifications

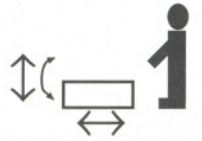

Move Product to Worker

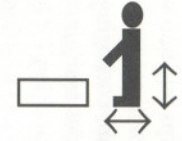

Move Worker to Product

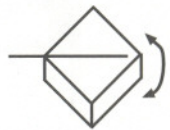

Rotate About Horizontal Axis

- Pallet Inverter
- Manipulator
- End Effector



Rotate About Vertical Axis

- Lift Table
- Manipulator
- Air Bearing
- Positioner/Balancer
- Vacuum Lift
- Hoist

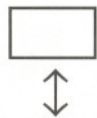

Lift From Below

- Lift Table
- Manual Lift Truck

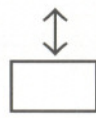

Lift From Above

- Manipulator
- Balancer
- Vacuum Lift
- Hoist

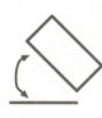

Tilt/Upend (Horiz. Axis)

- Lift Table
- Conveyor
- Manipulator
- Pallet Inverter
- End Effector

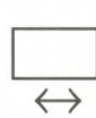

Transfer Supported Below

- Air Bearing
- Conveyor
- Lift Table
- Manual Lift Truck

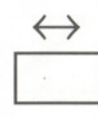

Transfer Supported Above

- Workstation Crane
- Manipulator



Lift From Below

- Adjustable Platform



Transfer Supported Below

- Adjustable Platform with Traverse

Industrial Scissors Lifts (Lift Tables)

Industrial scissors lifts are used in a wide variety of ergonomic applications where bottom-up movement is required. They are used in industries such as manufacturing, assembly, warehousing, distribution, sheet feeding, and printing, just to name a few.

Generally, scissors lifts, or lift tables (as they are sometimes called), may be used to position material so operators do not have to lift excessive loads, lift repetitively, or bend to do their jobs. These tables can include variations to facilitate horizontal movement on the deck such as conveyors or ball transfers. In addition, portability options for the base allow the complete unit to be moveable. Tilting devices can be added so loads can be positioned both vertically and angularly.

Scissors lifts can be adapted to any plant situation by choosing from different power options. For example, lifts can be powered with electric or air-powered hydraulic pump units, pneumatic lift systems or full mechanical lift systems.

Scissors lifts can be installed in any number of ways to meet specific requirements. Generally, they will be surface mounted or pit mounted. They can be either fixed in position or moveable in either case.

Lift Table

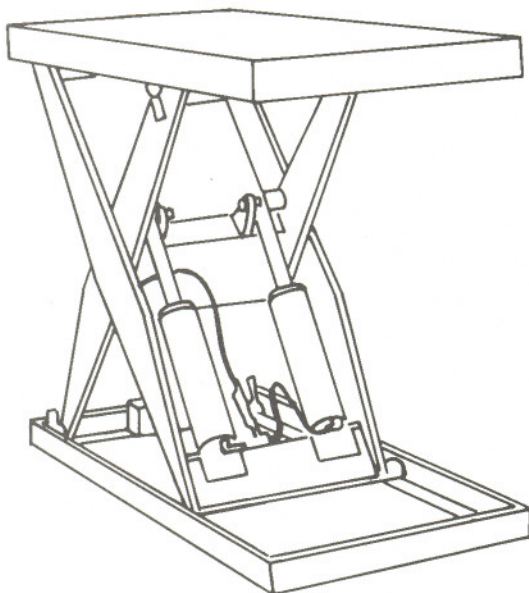

Typical Application

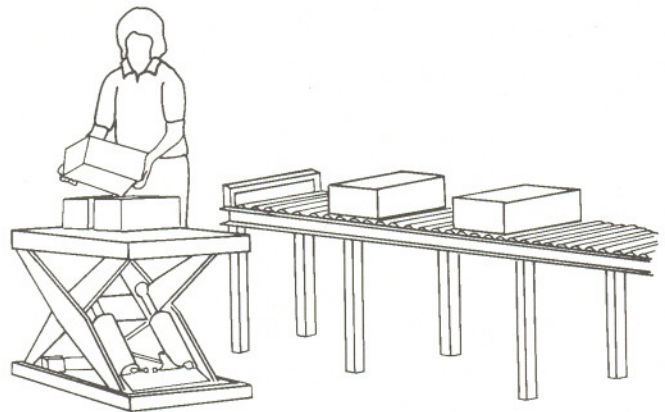

Adjustable Worker Elevation Platform

Adjustable Worker Elevation Platforms (AWEP) are used to provide significant ergonomic benefits by positioning the worker to the job.

There are many defined workstations in manufacturing facilities with points of human interaction at an elevation above the plant floor, requiring that the operator be positioned on a raised platform. Often times, these platforms are makeshift and can present safety hazards. It is also common for the plant maintenance department to fabricate non-adjusting platforms configured for the "average employee." These fixed-height platforms do not correctly accommodate the 5'-4" employee and the 6'-4" employee.

Multiple-shift operations, where three different operators interact with the same process machine in a 24-hour period, complicate the accommodation issue. Job rotation with operators changing jobs every couple of hours adds even more challenges to the workplace ergonomics issue. Job rotation may spread the risk of worker injury over a larger worker population, but it does not eliminate the risk. Modifying the characteristics of a workstation to reduce the number of bad choices an operator can make or providing operator control over the physical characteristics of workstation are proactive methods for addressing in-plant ergonomics issues.

AWEPs provide each operator with the ability to control their own position in relation to the task at hand, and position the task so that the operator can gain a biomechanical advantage over the task.

AWEPs are typically mechanically-driven devices that are manually adjusted. Platform sizes vary from 2' x 3' one-person units to larger runways parallel to assembly lines. Heights start as low as 2 1/4" above the shop floor. Most units have 12 inches of vertical adjustment. AWEPs can be pit-mounted, if necessary. Capacities are typically 400 lbs. Powered AWEPs can be activated using electricity or shop air.

AWEP

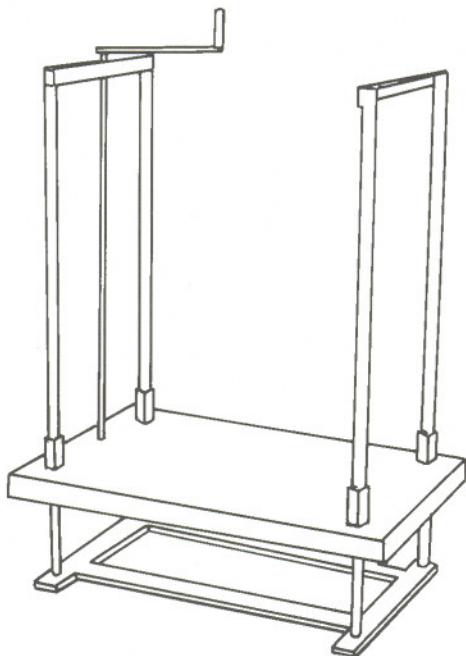

Typical Application

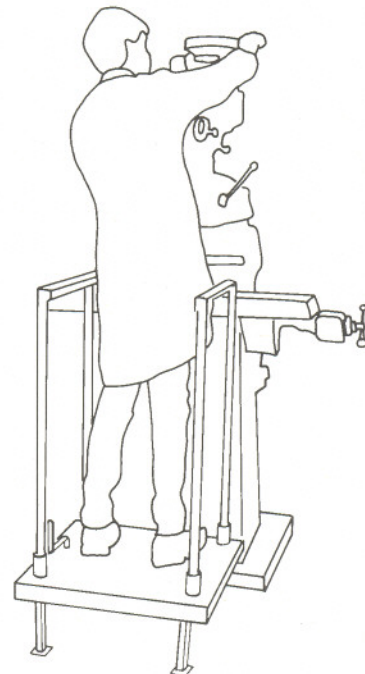

Balancers

These overhead devices provide and perform functions similar to overhead hoists in that they can lift and lower a load. The balancer configurations and suspensions are similar to a hoist.

The balancer functions differently from a hoist. The functional difference is indicated in the name "balancer." A balancer balances the load in a near weightless condition during the lifting operation. This feature allows the operator to maneuver the load easily. Balancers are often used for awkward and/or rapid load movements. Balancers can also be used to suspend equipment which is used in repetitive operation. A variety of control options are available. A very broad range of load handling devices (end effectors) can expand this product's versatility. Balancers are typically supported on small jibs, light monorail systems or tubular track monorail systems, or as part of a workstation.

Both air-powered and electronically driven balancers are commonly available. Balancers can weigh up to approximately 100 lbs. and have approximate lifting capacities of 500 lbs.

Balancer

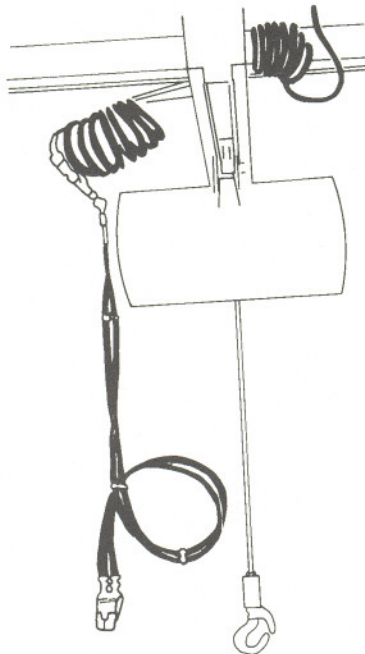

Typical Application

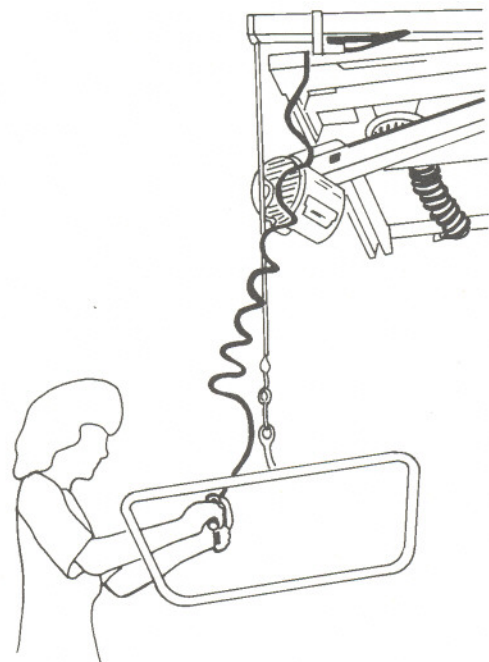

Manipulators

A manipulator has a mechanical arm which can move a load horizontally as well as vertically. Manipulators, unlike the hoist or balancer, can provide more than vertical lifting and lowering. Manipulators combine mechanical arms, cylinders/motors and application-specific load handling devices. The devices are often called end effectors. The devices are generally dedicated to a single product.

Manipulators can be floor-mounted, column-mounted, mounted overhead on a rail system or attached to a ceiling.

The machines are generally operator-controlled at or near the load control devices. The operator can manually manipulate the load in the pick, move and place functions. The load is in a near weightless condition similar to the balancer. Since the manipulator is often used to "reach" in the pick, move and place cycle, it is slower and may require more operator effort than a balancer.

Both products provide a wide range of ergonomic benefits. Balancers and manipulators provide a near weightless lifting situation, easy reach and orientation. They provide easy handling with difficult, rapid, repetitive or awkward applications.

Manipulators and balancers can be designed for a specific application. Before choosing a piece of equipment, you should consider its intended use. Either piece of equipment can adapt to different load sizes and shapes. Lift and lower distances are generally limited to the operator's reach.

Manipulator

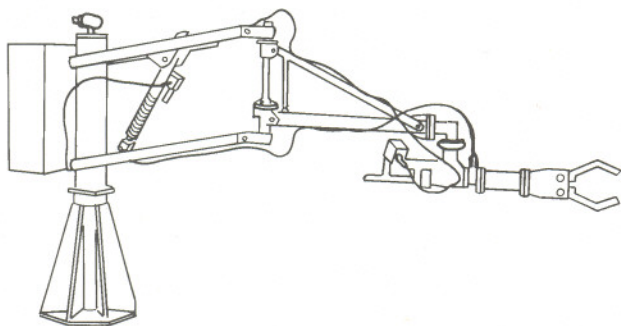

Typical Application

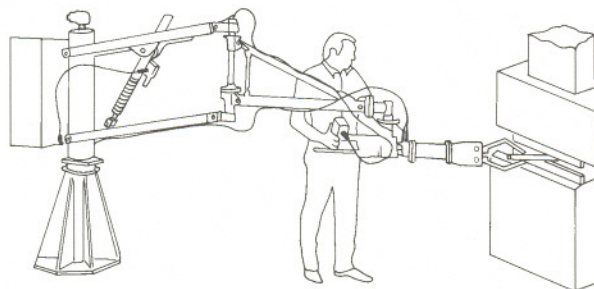

Vacuum Assist Devices

Vacuum tube lifters are ergonomically designed to reduce back strain, injuries and accidents therefore reducing or eliminating workers compensation claims. When using a lifter on a daily basis, worker fatigue should be greatly reduced and productivity increased. The lifter impact on the work place, because of its versatility, should help reduce absenteeism and downtime. Using the vacuum lifter can accomplish many repetitive lifting tasks ergonomically, quickly and skillfully, without delay.

Vacuum tube lifters have a wide range of capacities from as little as 40 pounds up to 1,000 pounds. These units are powered by anywhere from 3.5 h.p. up to 7.5 h.p. regenerative blower.

Most vacuum lifters offer many standard vacuum heads. These heads usually twist or snap on or off to change one head to another and can be done in a matter of seconds. There are a variety of standard vacuum heads designed for specific applications from situations involving narrow spaces with little room to maneuver, to load destinations which are higher than the operator's head, loads from sacks, to cartons, to 55 gallon drums, or large wood or metal sheets. Other standard heads enable the handling of different package shapes and surface types. There are even heads which can enable the operator to reorient cargo vertically or horizontally, with integral vacuum pump or pneumatic assist devices.

Vacuum Assist Device

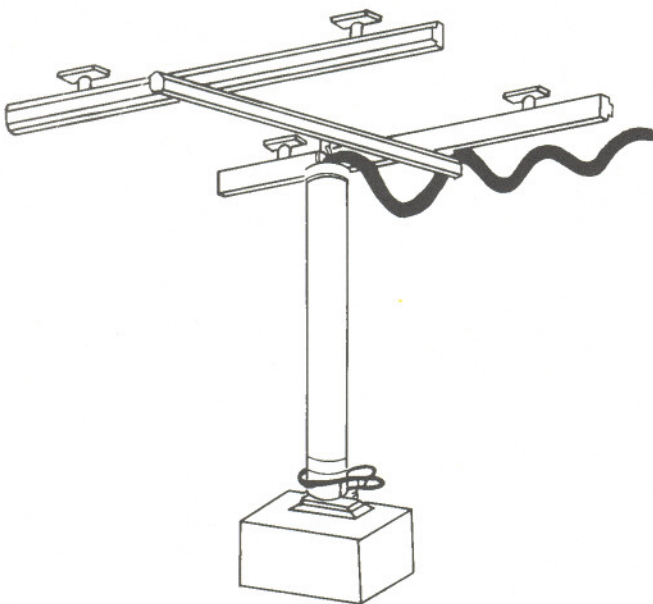

Typical Application

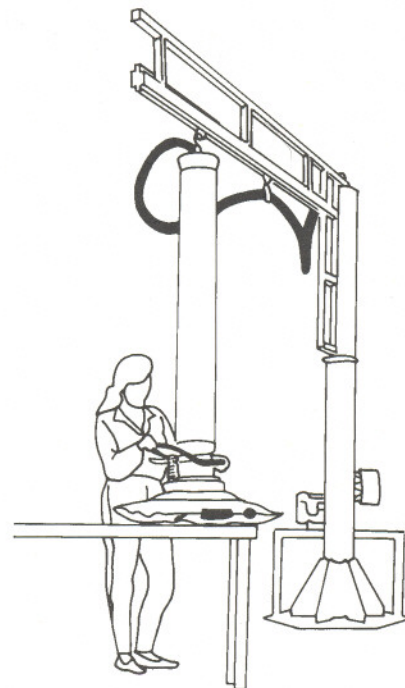

Workstation Cranes

Enclosed track workstation cranes are ergonomically designed for lighter loads, from 150 lbs. to 4,000 lbs. capacities. Horizontal movement is usually push, but can be powered. The high strength enclosed track design keeps rolling surfaces clean, which contributes to easier crane movement and longer wheel and track life. The tracks' low weight per foot reduces the dead weight, which makes for easier movement, increased worker safety and increased productivity.

Enclosed track workstation bridge cranes push very easily - typically 1 pound of force for every 100 pounds of load. This is much easier than an I-beam crane system that typically takes 3 pounds of force to move every 100 pounds of load. Ergonomically designed, easy to move workstation cranes put less stress on operators. They offer precise load positioning, significant productivity improvements, fewer injuries and less fatigue.

Equipment configurations include single or double girder bridge cranes, jib cranes and monorails. Both steel and aluminum cranes are available. Suspension is varied. The options include free standing floor support, ceiling suspended cranes or a combination of the two.

Load suspension trolleys, which ride on wheels inside the enclosed track, have devices that hang below the track opening to support vertical lift devices. These vertical lifting options include hoists, balancers, vacuum lifters and manipulators which contain holding and orienting devices such as hooks, slings, grabs, spreader bars, vacuum devices, custom end effectors and magnets. Enclosed track workstation cranes and monorails can offer ergonomic solutions to a single operation or an entire material handling system.

Workstation Crane

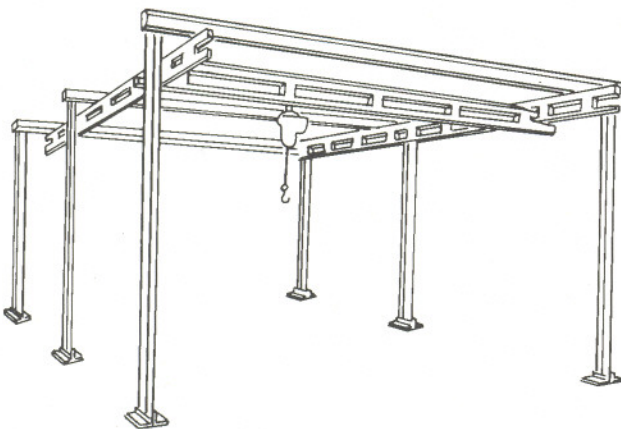

Typical Application

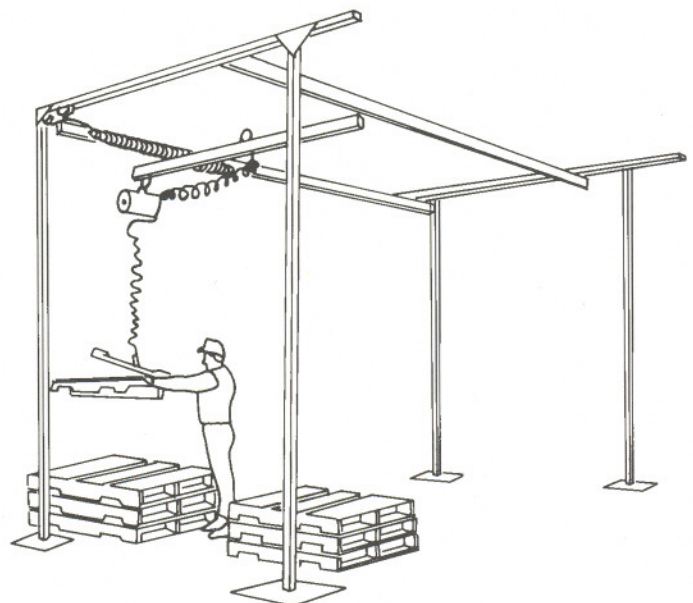

Workstations

Workstations meeting criteria relating to ergonomics should be designed to include the following:

- Vertical adjustment of the work surface. The surface should allow for persons of various heights and physiques to adjust the height to meet their physical characteristics. This would be especially true in multiple shift applications.
- Vertical height adjustment is also necessary as manufacturing or assembly work changes. The height required to assemble or manufacture should change as the product or subassembly changes. Vertical adjustments should compensate for the size of the component.

Considerations for a well designed workstation:

- 1) Everything the worker needs for the task should be available without stretching or reaching and should be easy to handle.
- 2) Items being handled should not require the hands to work at a level which averages more than 6" above the work surface.
- 3) Items in excess of 10 pounds should use a mechanical assist - nothing needs to be lifted from the floor.
- 4) The ideal work area should be semicircular around the worker.
- 5) The work surface should be at elbow height or slightly below it, so the forearm is horizontal or slightly slanted down.
- 6) Optimum height of work surface should be: For writing or light assembly - 27.5" to 31"; For heavier manual work - range of 26" to 28.5"
- 7) Work area should be well lighted with a glare eliminating system.

Workstation

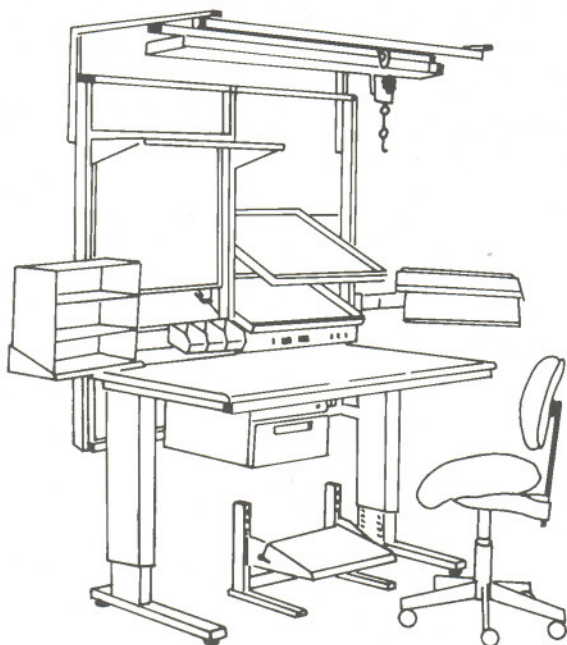

Typical Application

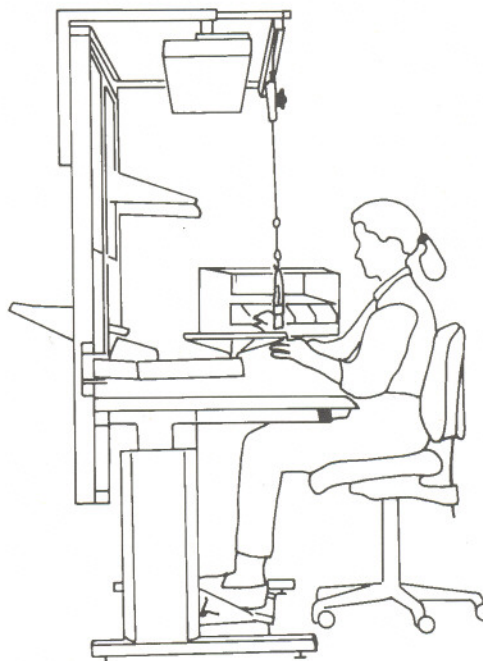

Stackers

Manually propelled lift trucks, commonly called stackers, can be an extremely versatile group of ergonomic assist products. They are designed to efficiently transport work from one work station to another, as well as, for elevating loads to comfortable ergonomic work heights.

Stackers are available with platforms, adjustable forks or fixed forks. Capacities range from 250 lbs. to 3,000 lbs., and load centers to 24", to handle load sizes up to 48" square.

Fork model stackers offer vertical level from floor level (5" for platform models) to 4', 5', 6', 8', 10' and 12' in lift height within a very small foot print. However, most ergonomic applications require only lower lift height models.

Hydraulics is the most frequently used method for lifting, although wire rope and winch are used with some lift weight manual types. Battery lifting power is most frequently used, but manual, AC electric, and air power models are available. A control lever is usually located at finger tip level on a control panel, but hand pendants and foot controls are also available.

Stackers effectively move, raise, and position wire baskets, tote boxes, crates, skids and pallets to proper ergonomic work levels for maximum efficiency, productivity, and worker safety. They are also available with numerous attachments and accessories to transport and position special work loads such as barrels, coils, rolls, etc.

Stacker

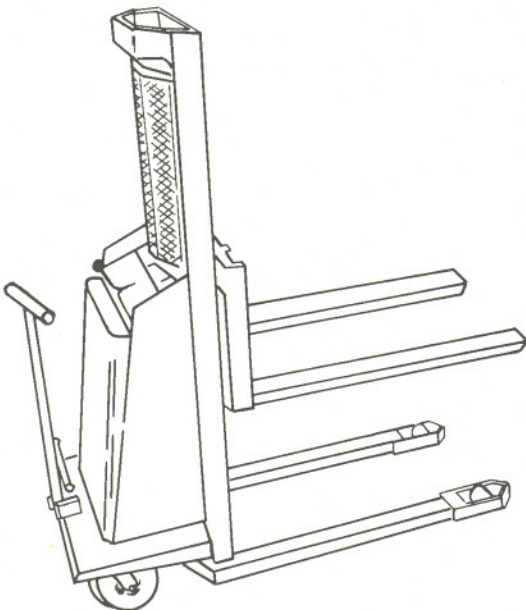

Typical Application

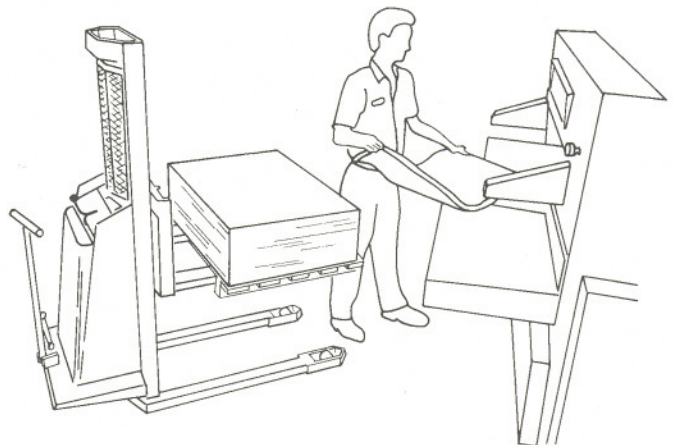

Conveyors

Conveyors are used in a variety of industries to transport unit/package loads from one location to the next. Conveyors in manufacturing operations are used primarily as part of the assembly process, while conveyors in warehousing and distribution are frequently used to process orders.

A conveyor provides an ergonomic advantage to the worker by providing a mechanized means of moving work to the worker. Expandable conveyors are ideal for assisting workers with tasks such as loading or unloading trucks and trailers. For order picking situations, conveyors provide workers with open cases at the proper height and in full view. This can mean fewer mistakes, less stooping, and less reaching.

Workers interfacing with conveyors are frequently engaged in bending, twisting, and reaching motions as they put on or take off materials from a conveyor. When using a conveyor system, it is important to evaluate the workstation design so that the equipment adjusts for the 6' tall worker on the first shift and the 4' 11" worker on the second shift.

Conveyor

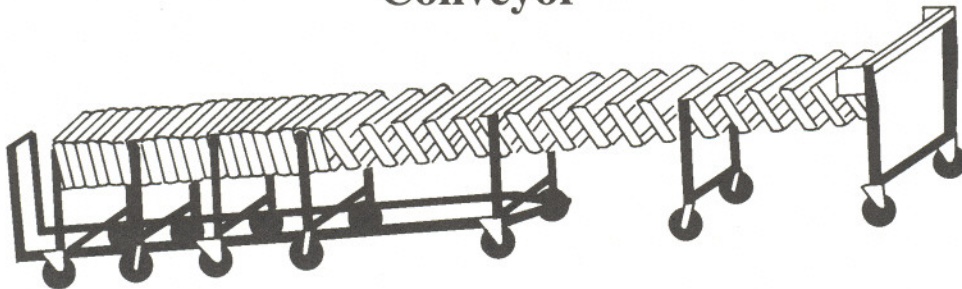

Typical Application

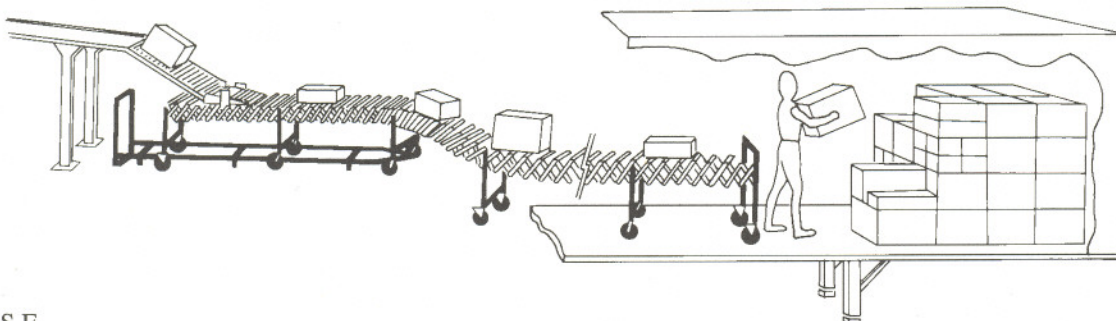

Container Tilters

Containers, boxes and baskets are widely used to store and transport parts and products. Although they are efficient, loading and unloading them requires motions that can be unsafe for workers. Regardless of how light the stored parts are, workers must repetitively bend, stoop, reach and lift as they work their way to the bottom of these containers.

To make the process safer and more productive, the container should be moved up and toward the worker as it is unloaded. Proper positioning can eliminate the need for bending, stretching, reaching and unnecessary lifting.

Pictured are portable tilters which allow containers to be picked up, moved into position, and tilted for easy access. There are similar stationary models which allow containers to be directly placed on the tilter by hand pallet trucks or fork trucks. In addition, there are floor height pivot point devices and tilters that mount on lift tables and other bases.

There are nearly as many tilter designs as there are container styles, and application information must be carefully considered before equipment selection. Special attention should be given to all container dimensions and the weight and configuration of the parts.

Container Tilter

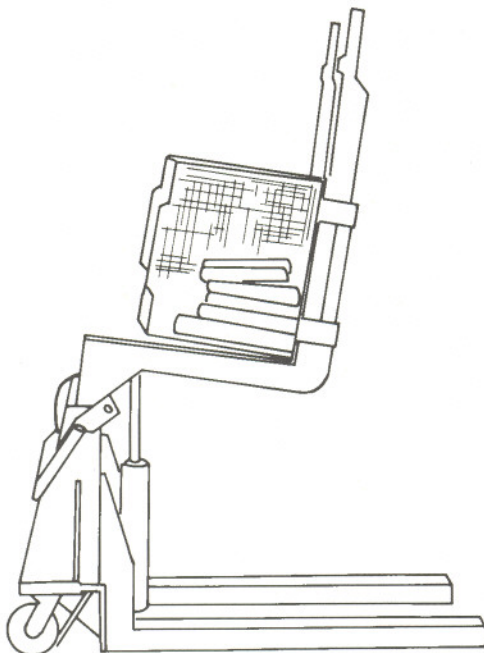

Typical Application

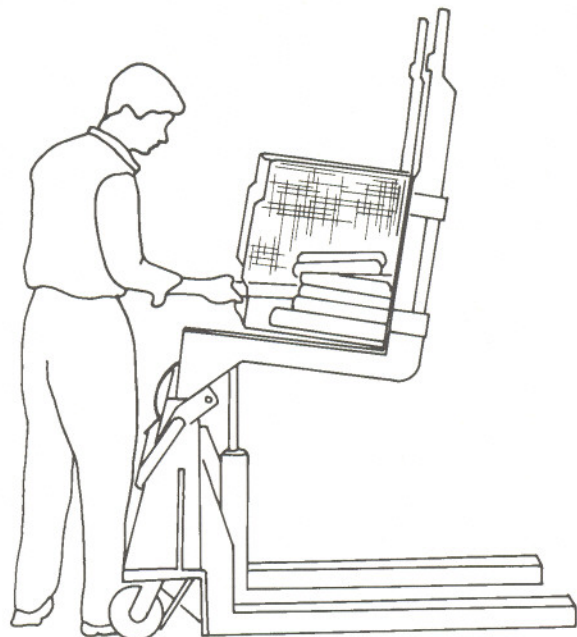

Pallet Rotator or Pallet Inverter

Throughout industry, shipping and storing goods on pallets is a methodology for transferring inventory. This type of unit load handling can create numerous materials handling challenges. Most of these difficulties are associated with restacking the pallet load and many can be handled by mechanically inverting the entire load instead.

Broken pallets can be easily removed and replaced. Crushed, damaged, or broken containers or bags can be pulled from the bottom of stacked loads by simply rotating the entire stack. Outgoing loads can be readily transferred from wood pallets to skids or slipsheets used for shipment. Incoming loads can be just as quickly transferred to permanent pallets used in racking systems or to special pallets for food handling and similar applications.

In operation, a pallet truck or fork truck is used to place palletized loads in the rotator. The pallet to which the load is to be transferred is placed on top of the stack. The rotator grips the load and rotates it 180 degrees, transferring the load from one pallet to the other.

Pallet Rotator/Inverter

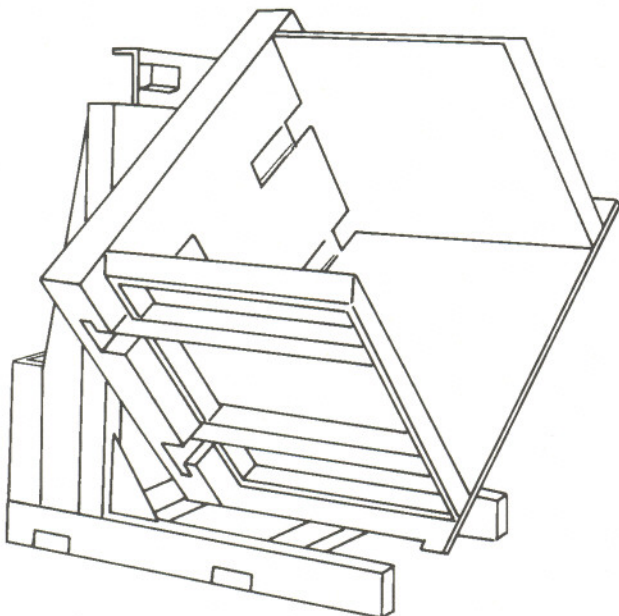

Typical Application

